

4. Installation of sensor

To ensure the optimum function of measuring equipment it is important that the installation instructions are followed closely, point by point.

4.1 Location

The flowmeter can be located both indoors and outdoors, but the following conditions must be observed:

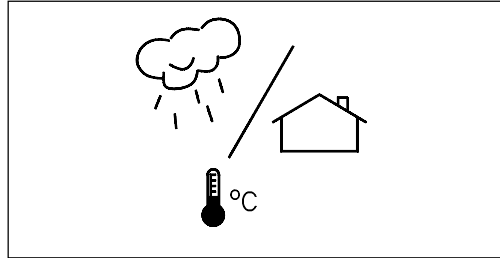

Liquid temperature: -58 to 356°F (-50 to +180°C). The grade of enclosure can be chosen from IP 20 up to IP 67.

When the temperature difference between a liquid and the surroundings is large, the sensor must be insulated to prevent 2-phase flow and thereby measuring inaccuracy. This applies especially in the case of low flow.

Important!

The sensor must **always** be completely filled with a homogeneous liquid or gas in single phase, otherwise measuring errors will occur.

4.2 Cavitation

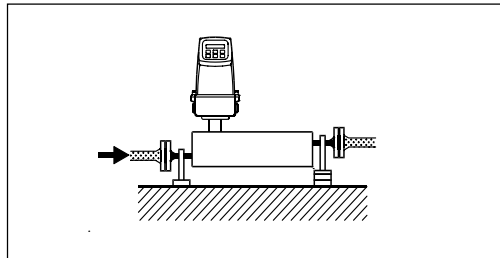

Avoid cavitation in the system, i.e. sucking in or releasing air into the system, because this may produce errors.

Static back pressure minimum 0.1 - 0.2 bar.

4.3 Airbubbles

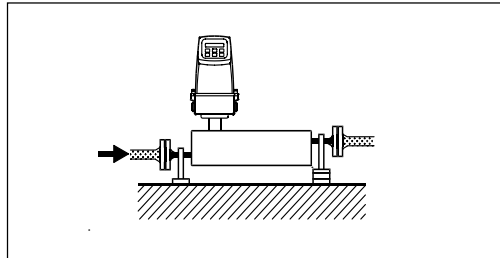

Avoid large quantities of air collecting in the sensor because these will disturb measurement. Homogeneous mixtures of air and solids, however, will not disturb measurement. When there is air in the liquid, installation of an air trap ahead of the meter is recommended.

If there is air/gas in the liquid or liquids which are volatile, horizontal sensor mounting is recommended.

4.4 Mounting

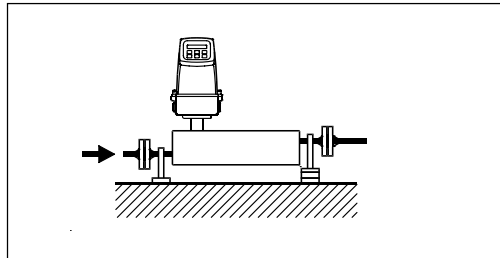

The unit must be mounted on a flat wall or steel frame (vibration-free).

4.5 Vibrations

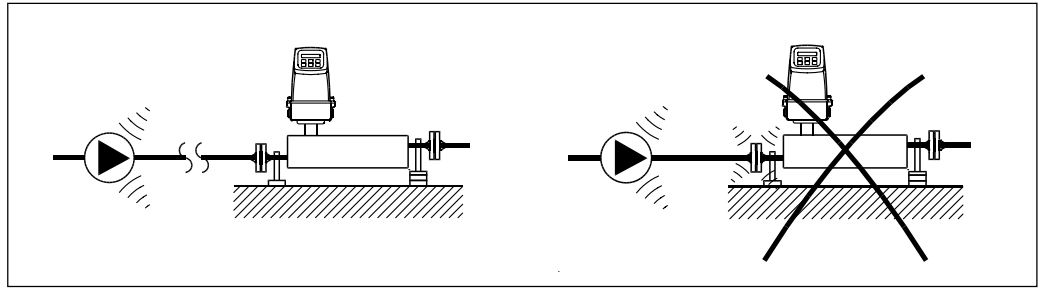

Locate the flowmeter as far away as possible from components that generate mechanical vibration in the piping.

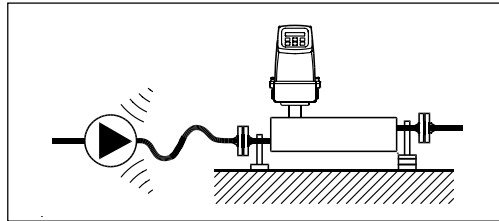

Or ensure that there is no direct connection with them e.g. by using flexible connections. The flowmeter can also be located after a bend.

4.6 Cross-talk

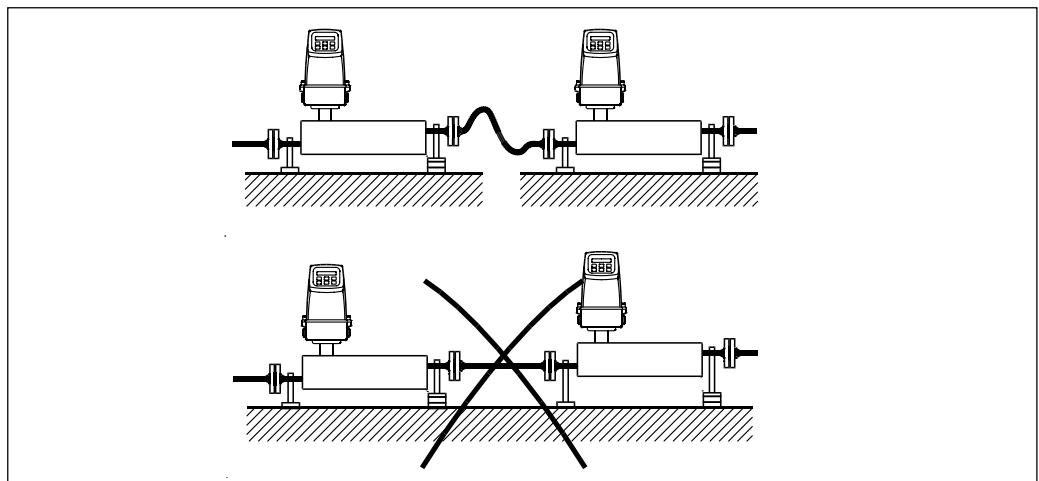

If the flowmeters are located close to each other, e.g. in the same pipe section, the meters may disturb each other in measurement, especially with low flow. Locate the meters with a flexible connection instead of a permanent connection. Avoid mounting the meter on the same steel frame. i.e. insulate the meters mechanically.

4.7 Magnetic fields

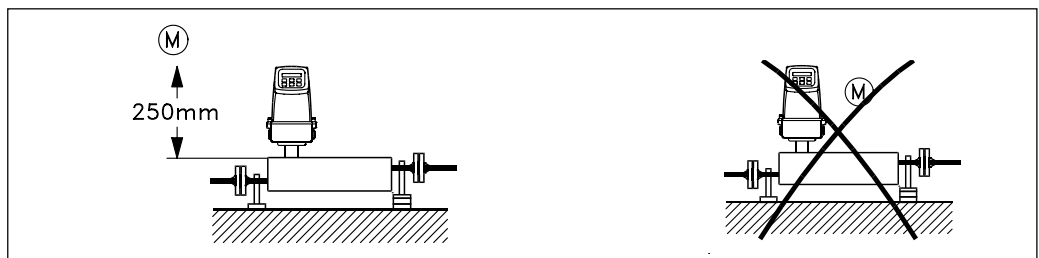

Locate the sensor a minimum of 10 inches (25 cm) from strong magnetic fields (motors, transformers, electrically operated valves, etc.).

4.8 Transportation/ storage

The sensor is a fragile piece of equipment and shall be placed in its storage carton when transported or stored. If this is not possible, the sensor must be packed so the packing enclosure can withstand the hazards from transportation or storage.

Installation of sensor

4.9 Horizontal mounting in pipe CMFB-F

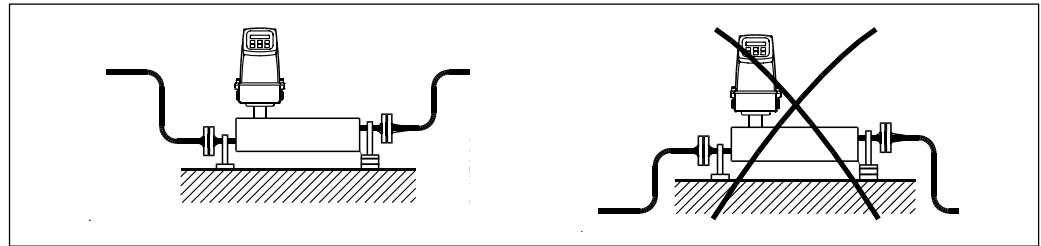

Locate the sensor low in the pipe system in order to avoid low pressure in the sensor and consequent air separation in the liquid.

If the flowmeter is mounted horizontally it is self-emptying.

With low flow, horizontal mounting is recommended, any air bubbles are easier to remove.

Flow direction

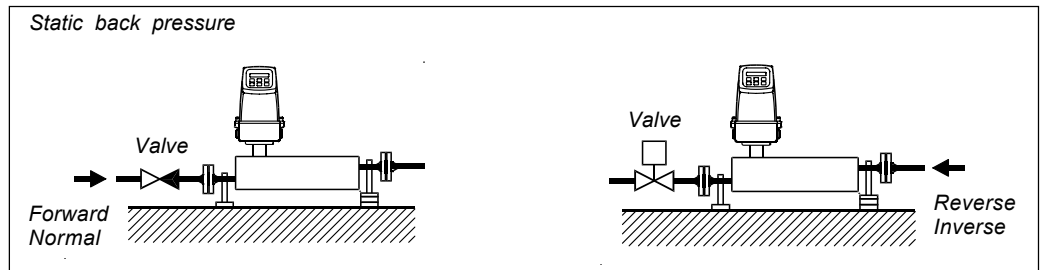

The arrow on the sensor indicates the direction of flow defined as "positive" (the meter is able to measure flow in both directions).

If possible, the liquid should flow in the forward direction to avoid partial emptying of the sensor, especially with low flow.

In addition there should be a valve (check/solenoid) that closes when the flow is zero so that the liquid does not flow back and causes partial emptying of the sensor.

0-point adjustment

To facilitate 0-point adjustment, a valve with a good shut-off should always be mounted near the sensor.

- The sensor should be completely filled with liquid.
- The valve must be closed.
- Wait a few minutes to let the flow stabilize at zero.
- Activate the 0-point adjustment, see Chapter 7 "Setting the 0-point".

4.10 Vertical mounting in pipe

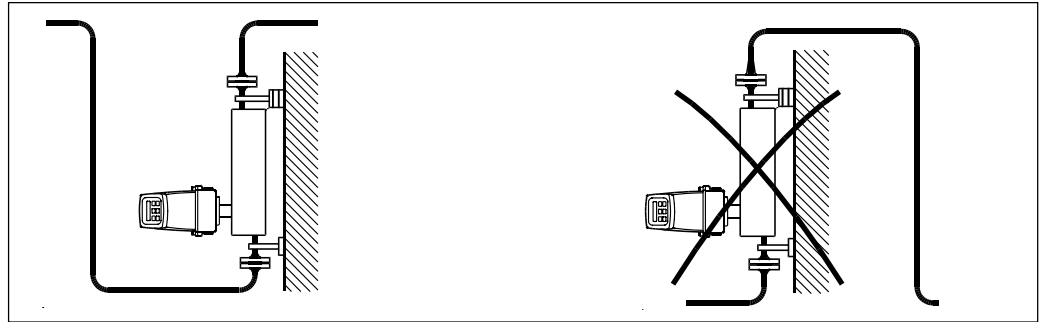

Locate the unit low in the pipe system in order to avoid under pressure in the sensor and consequent air separation in the liquid.

Flow direction

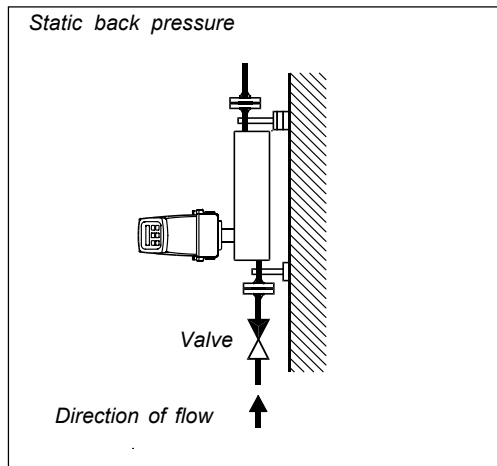

If possible, the liquid should flow up-wards to make bubble removal easier. With vertical mounting, a check valve, which closes on zero flow, must always be installed so that the liquid cannot flow back and partially empty the sensor.

The arrow on the sensor indicates positive (forward) flow direction.

0-point adjustment

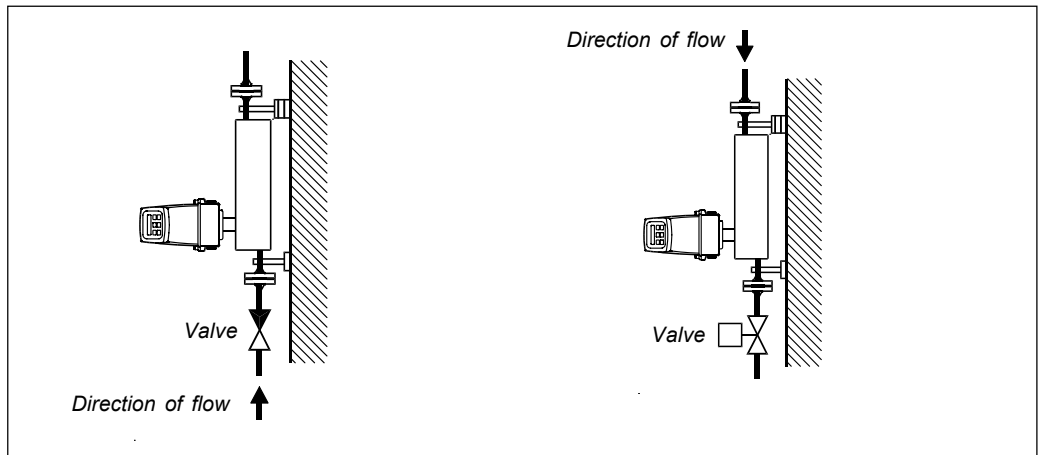

To facilitate 0-point adjustment, a valve with a good shut-off should always be mounted in line with the sensor.

- The sensor should be completely filled with liquid.
- The valve must be closed.
- Wait a few minutes to let the flow stabilize at zero.
- Activate the 0-point adjustment, see Chapter 7 "Setting the 0-point".

Installation of sensor

4.11 CMF - A

To ensure the optimum function of the measuring equipment it is important that the installation instructions are followed closely.

4.12 Location

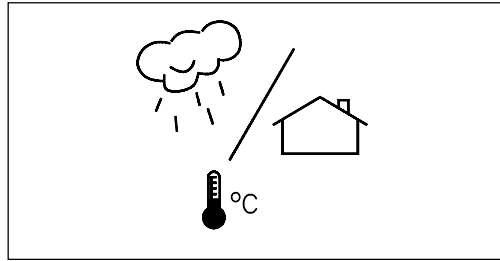

The flowmeter can be located both indoors and outdoors, but the following conditions must be observed:

Liquid temperature

The CMF - A is available in 2 versions.

Standard version: -40 to 257 °F (-40 to +125°C).

High temperature version: -40 to 356°F (-40 to +180°C).

For the high temperature version the multiple plug is raised from the sensor housing by a pipe. It is possible to insulate the sensor and still having access to the plug.



Important

When the temperature difference between a liquid and the surroundings is large, the sensor must be insulated to prevent 2-phase flow and the loss of measuring accuracy. This applies especially in the case of low flow.

The sensor must **always** be completely filled with a homogeneous liquid or gas in single phase, otherwise measuring errors will occur.

If there is air/gas in the liquid or liquids which are volatile, horizontal sensor mounting is recommended.

4.13 Mounting

The mounting bracket supplied with the unit must always be used. The bracket must be mounted on a wall or steel frame which is vibration free and mechanically stable.

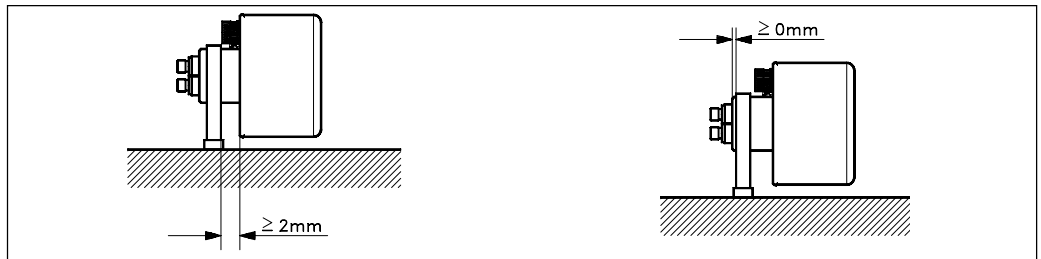

4.14 Horizontal mounting in pipe

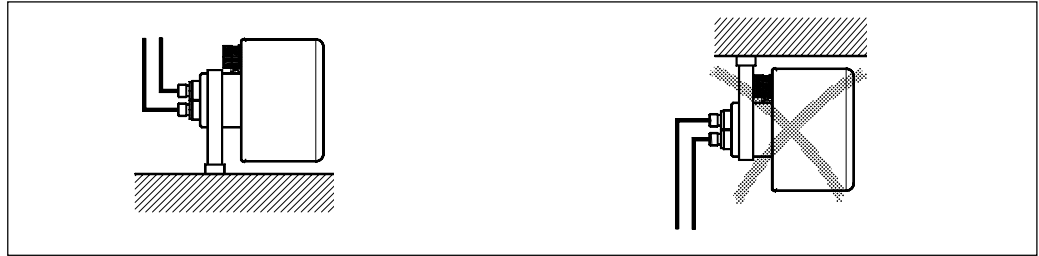

Locate the sensor low in the pipe system in order to avoid low pressure in the sensor and consequent air separation in the liquid. Due to the capillary tube effect, the sensor is not self emptying.

When there is low flow, horizontal mounting is recommended, the air bubbles are easier to remove.

To avoid separation of air from the liquid, a back pressure of min. 0.1 - 0.2 bar is recommended.

Multiple plug orientation

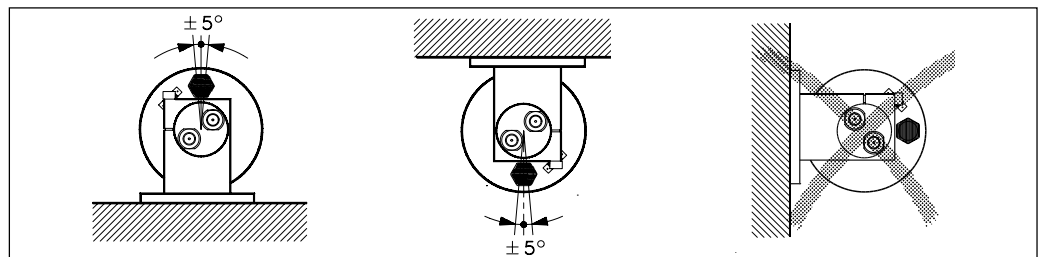

To obtain the optimum performance, the multiple plug should be mounted as shown in the drawing. The multiple plug can be turned with the angles stated.

Flow direction

The arrow on the sensor indicates the direction of flow defined as "positive" (the meter is able to measure flow in both directions).

If possible, the liquid should flow in the direction of the arrow (on the sensor) to avoid partial emptying of the sensor, especially with low flow.

0-point adjustment

In addition there should be a valve (check/solenoid) that closes when the flow is zero so the liquid does not flow back to produce partial emptying of the sensor.

To facilitate a good 0-point adjustment a valve should always be installed to ensure that 0-flow condition can be obtained.

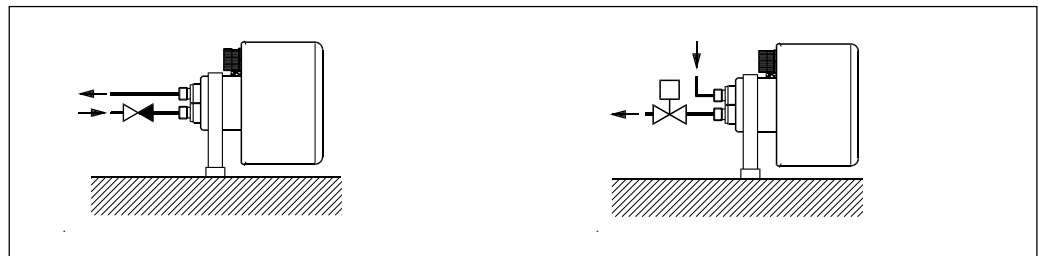

- The sensor should be completely filled with liquid.
- The valve must be closed.
- Wait a few minutes to let the flow stabilize at zero.
- Activate the 0-point adjustment, see Chapter 7 "Setting the 0-point".

4.15 Vertical mounting in pipe

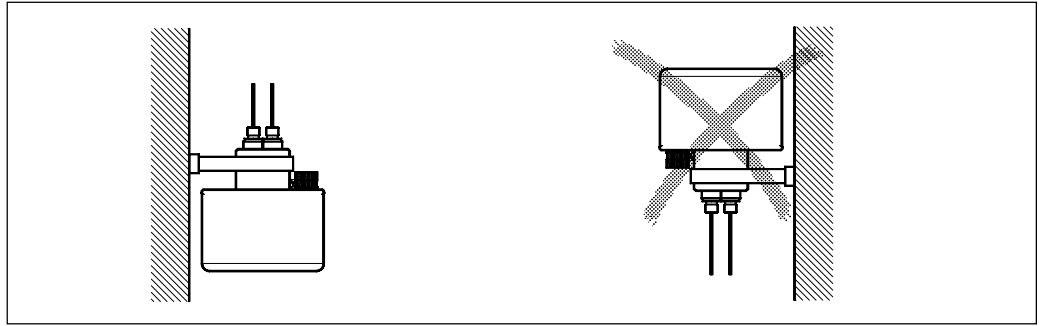

Locate the unit low in the pipe system in order to avoid low pressure in the sensor and consequent air separation in the liquid.

Multiple plug orientation

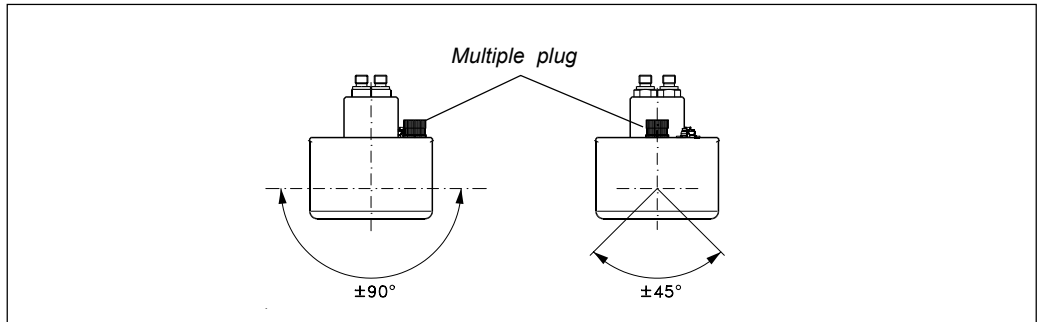

When mounting vertically, the orientation of the terminal box is not important, rotation, however, is not allowed to exceed the stated angles of the sensor.

Flow direction

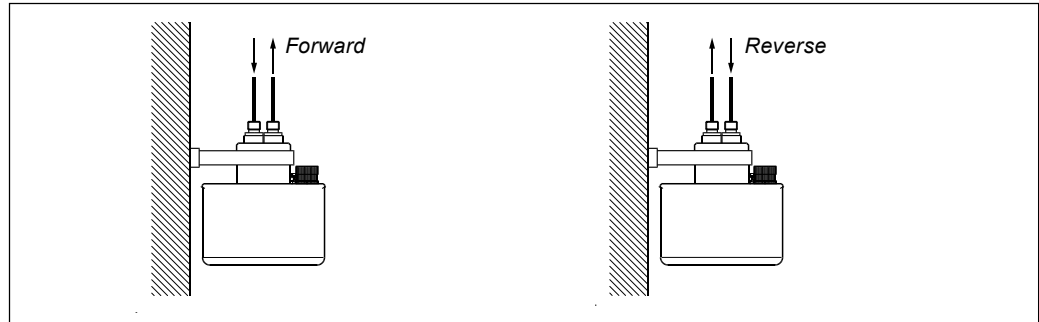

The arrow on the sensor indicates the direction of flow defined as "positive" (the meter is able to measure flow in both directions).

4.16 Before commissioning



Warning

Before installing the sensor read the maximum operating pressure (PN) on the sensor label. The operating pressure indicates the pressure to which the measuring pipe and connections have been designed for. The sensor has passed pressure tests of this value or greater. This, is not the case with the sensor enclosure (i.e. the enclosure covering the measuring pipe). If for some reason the measuring pipe fractures, a pressure will be generated in the enclosure.

The burst pressure for the CMF - B through F enclosure is approximately 725 psi (50 bar) and approximately 1000 psi (70 bar) for CMF - A.

The pressure values are only approximate and therefore cannot be taken as an absolute value indicating when a possible fracture or leakage will occur.

When working with operating pressures/media which may cause pipe fractures and possible injuries to people, equipment or anything else, special precautions are recommended to be taken when building-in the sensor i.e. special placement, shielding, pressure release valve or similar.

The sensor enclosure is supplied with a 1/8" nipple. When the nipple is removed a pressure release valve can be connected to automatically shut off the flow to the sensor in case of leakage. For instructions on the mounting, please refer to the section "Mounting of pressure release valve".

4.17 Mounting of pressure release valve

Important

Before removing the nipple from the sensor enclosure, note the following: Penetration of humidity, liquid or particles into the sensor must be avoided as it may influence the measurement and in worst case affect the measuring function. This, can be avoided when following the procedure below:

1. Place the sensor in a dry, clean place leaving it to settle until it reaches ambient temperature, approximately 68° F (20 °C).
2. Be careful when disconnecting the nipple and mounting the pressure release valve.
3. Check that the pressure release valve has been correctly mounted and thoroughly tightened so that the sealing ring fits tightly. Always replace old sealing rings with new ones after each removal.

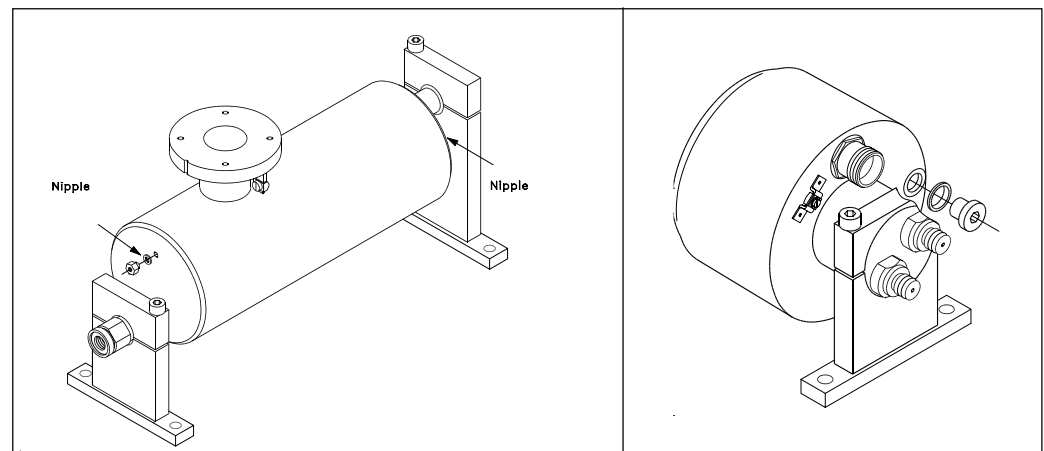

4.18 Ex installations

Transmitters

The instrument can be used in a 19" rack version where the sensor can be installed in the ex-area. The transmitter must be installed in a safe area or as compact (integral) Ex-d version for installation in the ex-area.

For mounting in Ex areas

Approval EEx [ia] IIC T4...T6. DEMKO No. 95D.117700X

19" Ex for mounting in safe areas

Approval EEx [ia/ib] m IIB T4...T6. DEMKO No. 99E.125729X.

Ex-d system

Approval Ex de [ia] IIC T4...T6. DEMKO No. 99E.124212X.

Marking

The marking has the following meaning according to European Norm EN 50014.

- E: Certified to CENELEC standard.
- Ex: Designates explosion proof material and indicates that the apparatus has been approved in accordance with a certificate issued.
- i: "Intrinsic safety" is a protection ensuring that the energy in the electric circuit is too small to ignite the explosive atmosphere. There are two categories of intrinsic safety: "ia" and "ib".
 - ia: In intrinsic safety category "ia", the circuit must remain safe, even in the event of two simultaneous errors occurring that are independent of one another.
 - ib: In intrinsic safety category "ib" the circuit must remain safe if one error occurs.
- d: The enclosure of the of the signal converter is so strong that it can resist an explosion inside the enclosure. The enclosure is dimensioned in a way so that an explosion will not effect the surroundings.
- e: "Increased safety" is a constructional safeguard which ensures the apparatus does not contain normally arcing or sparking devices, or hot surfaces that will cause ignition.
- II: Designates that the apparatus may be used in all areas (except mining).
- B: Indicates the gas group in which the unit may be used.
- T4...T6 The temperature class describes the maximum temperature which any exposed surface of the equipment may reach. The sensor can have temperature class T3, T4, T5 or T6 depending on the temperature of the media. Please see technical data for the sensor.
 - T3: Max. surface temperature 392°F (200 °C) => (Max. media temperature 356°F (180 °C))
 - T4: Max. surface temperature 275°F (135 °C) => (Max. media temperature 248°F (120 °C))
 - T5: Max. surface temperature 212°F (100 °C) => (Max. media temperature 194°F (90 °C))
 - T6: Max. surface temperature 185°F (85 °C) => (Max. media temperature 167°F (75 °C))