

FCI FLUID COMPONENTS
INTERNATIONAL LLC

Installation, Operation & Maintenance Manual

Installation, Betrieb und Wartungshandbuch

La instalación, Manual de Operación y Mantenimiento

安装、操作和维护手册

FLT[®] 93 Series FlexSwitch[™]
Flow, Level, Temperature Switch / Monitor

Models: FLT93B, FLT93C, FLT93F,
FLT93L, FLT93S

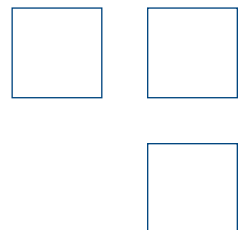
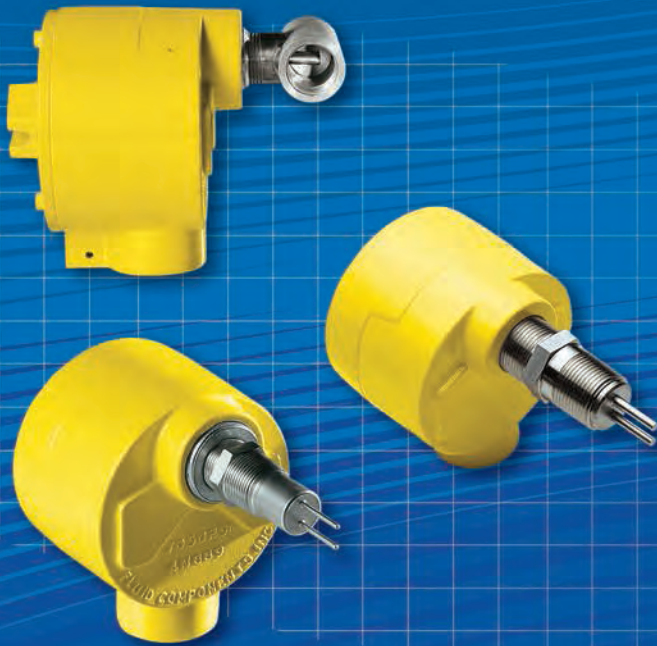

Notice of Proprietary Rights

This document contains confidential technical data, including trade secrets and proprietary information which is the property of Fluid Components International LLC (FCI). Disclosure of this data to you is expressly conditioned upon your assent that its use is limited to use within your company only (and does not include manufacture or processing uses). Any other use is strictly prohibited without the prior written consent of FCI.

© Copyright 2013 by Fluid Components International LLC. All rights reserved.

Manufactured in accordance with one or more of the following patents: 5,600,528; 6,340,243. FCI is a registered trademark of Fluid Components International LLC. Information subject to change without notice.

Table of Contents

1 GENERAL.....1

 Description.....1

 Theory of Operation.....1

 Sensing Element.....1

 Control Circuit.....1

 Technical Specification.....2

2 INSTALLATION5

 Receiving/Inspection.....5

 Packing/Shipping/Returns.....5

 Factory Calibration Note.....5

 Pre-Installation Procedure.....5

 Use Standard ESD Precautions.....5

 Prepare or Verify Sensing Element Location.....5

 Verify Dimensions.....5

 Verify Sensing Element Flow Direction and Placement Orientation (Flow Application).....5

 Install the Sensing Element.....6

 Male NPT Mounting.....6

 Flange Mounting.....6

 Packing Gland Assembly.....7

 In-line NPT Assembly (FLT93-L).....7

 Sanitary Assembly (FLT93-C).....8

 Install and Wire the Enclosure(s).....8

 Disconnect Device.....8

 Minimum Wire Size.....8

 Enclosures Covers.....8

 Cable and Conduit Entry Devices.....9

 Wiring the Local Enclosure Configuration.....9

 Wiring The Remote Enclosure Configuration.....10

 Locate the Remote Hardware Location.....10

 Wiring Output Signal Terminals.....11

 Wiring Input Power.....11

3 OPERATION15

 Factory Default Jumper Configuration.....15

 Configuration Jumpers.....15

 Heater Cut-Off.....15

 Alarm Set Point Adjustments.....16

 Numerical Adjustment Versus Adjustment by Observation.....16

 Numerical Alarm Set Point Adjustment.....17

 Air/Gas Flow Applications.....17

 Wet/Dry Liquid Level Applications.....20

 Liquid Flow Applications.....21

 Adjustment by Observation.....23

Flow Applications.....	23
Level Applications.....	24
Temperature Applications.....	24
Converting Temp Out Voltage to Temp in Degrees F or Degrees C.....	26
Fail Safe Alarm Setting.....	32
Low Flow Alarm Settings.....	32
High Flow Alarm Settings.....	32
Low Level Alarm Settings (Sensing Element Normally Wet).....	33
High Level Alarm Settings (Sensing Element Normally Dry).....	33
4 MAINTENANCE.....	35
Maintenance.....	35
Calibration.....	35
Electrical Connections.....	35
Remote Enclosure.....	35
Electrical Wiring.....	35
Sensing Element Connections.....	35
Sensing Element Assembly.....	35
5 TROUBLESHOOTING.....	37
Tools Needed.....	37
Quick Check.....	37
Non-maintenance Observations.....	37
Check Serial Numbers.....	37
Check Input Power.....	37
Check the Instrument Installation.....	37
Check for Moisture.....	37
Check Application Design Requirements.....	37
Troubleshooting the Flow Element.....	38
Troubleshooting the Control Circuit.....	40
Spares.....	41
Defective Parts.....	41
Customer Service.....	41

APPENDIX A DRAWINGS	43
APPENDIX B GLOSSARY	73
APPENDIX C APPROVAL INFORMATION	75
EC Information.....	75
Safety Instructions for the use of the FLT93 Flowswitch in Hazardous Areas	77
APPENDIX D TEMPERATURE COMPENSATION	81
Introduction.....	81
Factory Temperature Compensation Settings	81
Balance Procedure.....	82
Field Temp Comp Calibration.....	82
APPENDIX E CUSTOMER SERVICE	85
Customer Service/ Technical Support.....	85
Warranty Repairs or Returns.....	85
Non-Warranty Repairs or Returns.....	85
Warranty.....	86
Return to Stock Equipment.....	86
Field Service Procedures	86
Field Service Rates.....	86
Return Authorization Request.....	87

INTENTIONALLY LEFT BLANK

1 GENERAL

Description

The FLT Series models are multipurpose measurement instruments. The models included in this manual are FLT93-C, FLT93-F, FLT93-L and FLT93-S. Each model is a single instrument that is capable of detecting fluid flow and temperature. It is also able to detect liquid level or fluid media interfaces. The instrument has two field adjustable alarm set points, two buffered voltage outputs, as well as a built-in calibration circuit. The output of the alarm set points are relay contacts that can be used to control customer process applications. One buffered voltage output is available for flow or level monitoring and the second buffered voltage output is available for temperature monitoring.

Theory of Operation

The flow switch is a fixed position, single-point flow, level, interface and temperature switch. The operation of the sensing element is based upon the thermal dispersion principle: A low-powered heater is used to produce a temperature differential between two Resistance Temperature Detectors (RTDs). The RTD temperature differential varies as a function of forced convection for flow measurement and as a function of fluid thermal conductivity for level and interface measurement. The measurement of the fluid's temperature is obtained from the non-heated RTD.

Sensing Element

The sensing element consists of two thermowells (hollow tubes) that when inserted into the flow process allows an unimpeded flow inside the process line. The top thermowell has a heated RTD inserted into it. The bottom thermowell has a reference RTD inserted into it. In order to correctly orient the sensing element a flow arrow has been etched onto the threaded portion of the sensing element. See Figure 1-1 for a view of the sensing element.

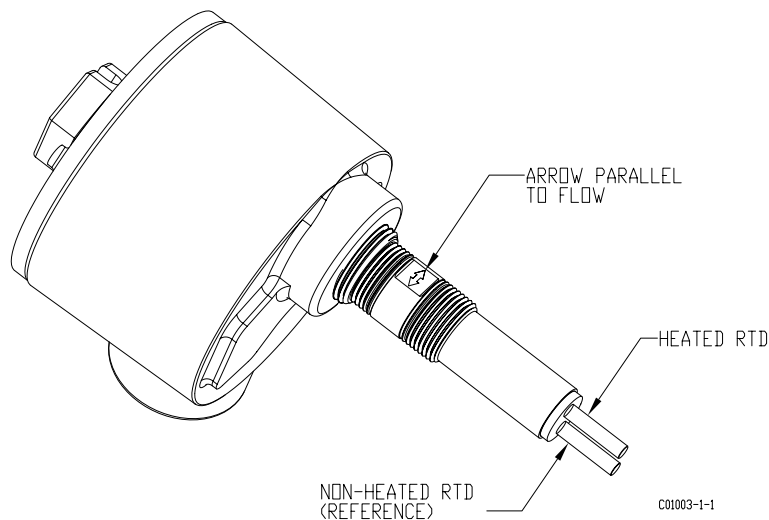

Figure 1-1 View of the Sensing Element

Control Circuit

The control circuit converts the sensing element's RTD temperature differential into an analog DC voltage signal. Dual comparators monitor the sensing element signal and activates the relay alarm circuits if the signal exceeds an adjustable set point.

The control circuit contains field removable jumpers that configures the instrument to perform in the field as needed by the customer.

Technical Specification

Application

Flow rate and /or level /interface and temperature sensing in liquid, gas and slurry applications.

Sensing Elements

■ **Process Connection**

Models S and F

3/4 inch male NPT standard; optional 1 inch BSP, 1 inch male NPT, 3/4 inch Male NPT (FLT93-F only); flanges, spool pieces, sanitary fittings or retractable sensing element optional.

Model L

1" male NPT or 3/4" female NPT, both ends with orifice; flanges optional.

Model C

Sanitary flange

■ **Insertion Length**

Models S and F

Available in standard lengths of 1.2" [30mm], 2" [51mm], 4" [102mm], 6" [152mm], 9" [229mm], 12" [305mm], 18" [457mm] and custom-specified lengths.

Model L

3.375" [86mm] in-line body length

Model C

Please see chart on outline dimensional.

■ **Sensing Element**

Models S and F

All wetted surfaces are 316L stainless steel with all-welded construction. Hastelloy C, Monel 400, electro-polished stainless steel and titanium (FLT93-S only) are optionally available. Other spray coatings are available on special request (i.e., tantalum, chromium carbide).

Model L

All wetted surfaces are 316L stainless steel with all-welded construction. Hastelloy C, Monel 400 and titanium are optionally available.

Model C

All wetted surfaces are 316L stainless steel with all-welded construction electro-polished to 20 Ra.

■ **Operating Temperature**

Sensing Element:

All Models

Standard temperature configuration:

-40° to +350°F [-40°C to +177°C]

Medium temperature configuration:

-100°F to +500°F [-73°C to +260°C]

Model S Only

High temperature configuration:

-100°F to +850°F [-73°C to +454°C]

Control Circuit:

All Models

Ambient -40°F to +140°F [-40°C to +60°C]

■ **Operating Pressure**

Models S, F and L

2350 psig [162 bar(g)] maximum at 500°F [260°C]

1450 psig [100 bar(g)] maximum at 850°F [454°C]

Model C

2000 psig [138 bar(g)] maximum

Higher ratings available with special construction and test certification.

Environmental Conditioning

Indoor or outdoor use.

Maximum Relative Humidity: 100%

Maximum Altitude: 12,000 ft.

Control Circuit Features

■ **Control Circuit**

Standard: Plug-in, socket mounted with dual alarm/trip epoxy sealed relays.

Optional: Rack-mount configuration (card cage or enclosure not included)

■ **Output Signal**

Analog DC voltage related to flow or level / interface signal and proportional to temperature, standard.

■ **Input Power**

Field selectable for 120 Vac (108-132 Vac), 13 watts 100 mA

maximum; 230 Vac (216-240 Vac), 14 watts 50 mA maximum;

24 Vdc (21-30 Vdc), 7 watts, 230 mA maximum or 24 Vac (18-28 Vac), 7 watts, 230 mA maximum.

Optional low supply voltage operation, for applications with line voltage supplies lower than 108 Vac, field selectable for 105 Vac (93-115 Vac), 13 watts, 100 mA maximum; 210 Vac (184-226 Vac) 14 watts, 50 mA maximum.

All AC power rated at 50-60 Hz. Power "ON" amber LED provided.

■ **Serviceable Fuse Rating**

For the 120/240 Vac input power configuration, there are two serviceable fuses located on the top side of the control circuit. These are labeled F1 and F2.

Fuse Specifications

Power: 1.6 Amps, 250 Vac, SLO-BLO® (time delay)

Package size: TRS (8.5 x 8 mm) radial lead plug-in type

FCI part number: 019933-01

Tyco part number: 37411600410

For the 24 Vdc/Vac input power configuration, there is a fuse located on the bottom side of the control circuit. The replacement of this fuse requires a qualified technician knowledgeable in SMD, and RoHS soldering practices.

Fuse Specifications

Power: 1.5 Amps, 125 Vdc, SLO-BLO® (time delay)

Package size: 6.1 x 2.69 mm SMD

FCI part number: 020399-02

Little Fuse part number: 045201.5

■ **Heater Power**

Field or factory selected to optimize switching performance and rangeability and selectable for specific fluid service requirements.

Typical Service	Sensing Element	Power (W)
Gas or Air	S-Style	0.75
	F-Style	0.25
Liquids	S-Style	3.0

The above typical service power selections are for reference

only. Depending on application requirements, surface temperature rating requirements, and rangeability expectations, alternate power selections may be recommended. Other intermediate power selections can be made. Consult installation manual for recommendations in your service.

■ **Relay Rating**

Standard: Dual alarm relays, SPDT or single alarm DPDT field configurable, 6 amps resistive load at 240 Vac, 120 Vac, 24 Vdc.
Optional: Dual alarm SPDT or single alarm DPDT field configurable hermetically sealed relay, 0.5 amps at 115 Vac/2amps at 28 Vdc.

■ **Electrical Enclosure**

Aluminum (epoxy coated) or optional stainless steel. Enclosures are rated for hazardous location use (Class I and II, Division 1 and 2, Group B, C, D, E, F and G; and EEx d IIC) and resists the effect of weather and corrosion (NEMA and CSA Type 4X and equivalent to IP66).

For Flow Service

■ **Setpoint Range**

Model S

Water-based Liquids:

0.01 FPS to 0.5 FPS [0.003 MPS to 1.52 MPS] with 0.75 watt heater; 0.01 FPS to 3.0 FPS [0.003 MPS to 0.9 MPS] with 3.0 watt heater.

Hydrocarbon-based Liquids:

0.01 FPS to 1.0 FPS [0.003 MPS to 0.3 MPS] with 0.75 watt heater; 0.01 FPS to 5.0 FPS with [0.003 MPS to 1.5 MPS] with 3.0 watt heater.

Air/Gas:

0.25 SFPS to 120 SFPS [0.08 NMPS to 37 NMPS] with 0.75 watt heater at standard conditions; 70°F [21.1°C], 14.7 psia [1.013 bar(g)].

Other Fluids: Contact the factory for approximate rangeability.

Model F

Air/Gas:

0.25 SFPS to 120 SFPS [0.08 NMPS to 37 NMPS] 0.75 watt heater at standard conditions; 70°F [21.1°C], 14.7 psig [1.013 bar(g)].

Model L

Water-based Liquids: 0.015 cc/sec to 50 cc/sec

Hydrocarbon-based Liquids: 0.033 cc/sec to 110 cc/sec

Air/Gas: 0.6 cc/sec to 20,000 cc/sec

Model C

Water-based Liquids: 0.01 FPS to 3.0 FPS [0.003 MPS to 0.9 MPS]

Syrup: to 5.0 FPS [0.003 MPS to 1.5 MPS]

Air/Gas: 0.25 SFPS to 120 SFPS [0.08 NMPS to 36.6 NMPS]

■ **Factory Calibrated Switch Point Accuracy**

Any flow rate within the instrument flow range may be selected as a setpoint alarm. A factory-calibrated setpoint adjustment may be optimally preset with accuracy of ±2% of setpoint velocity over an operating temperature range of ±50°F [±28°C].

■ **Monitoring Accuracy**

Based on a measured output voltage over the entire flow range, an operating temperature range of ±50°F [±28°C], and an operating pressure range of ±100 psig [±7 bar(g)]:

Liquids: ±5% reading or ±0.04 SFPS [±0.012 NMPS], whichever is larger.

Gases: ±5% reading or ±2 SFPS [±0.61 NMPS], whichever is larger.

■ **Repeatability**

±0.5% reading

For Level/Interface Service

■ **Accuracy**

Model S

±0.25° [±6.4 mm]

Model F

±0.1° [±2.5 mm]

■ **Repeatability**

Model S

±0.125° [±3.2 mm]

Model F

±0.05° [±1.3 mm]

For Temperature Service

■ **Accuracy**

±2.0°F [±1°C] with field setpoint adjustment. Monitoring accuracy ±3.5°F [±2°C] with standard curve fit output voltage operation across the selected instrument temperature range. Higher accuracy available with factory calibrations.

■ **Repeatability**

±1.0°F [±0.6°C]

The above accuracy is based on liquid or slurry service and in gas service with a minimum 1 SFPS [0.3 NMPS] velocity past the sensing element or with the heater deactivated for temperature sensing service only.

■ **SIL**: SIL-2 compliant, safe failure fraction (SFF) 82% to 84%

Factory Application-Specific Set-up and

Setpoint Calibration

Standard instrument factory default setting, unless otherwise selected at order entry, will be as follows:

- 120 Vac input power for all domestic units.
- 230 Vac for all other agency approval units. Field selectable.
- Dual SPDT alarms set for:
- Alarm No. 1: Preset for flow or level and to de-energize with decreasing conditions.
- Alarm No. 2: Preset to de-energize for increasing temperature at 10 °F [5 °C] below the maximum instrument process temperature.
- Heater power at 0.25 watt on Model F or 0.75 watt on Model S.
- Calibration switch set at "operate."

Factory calibration including set-up for specific service, process fluid and alarm conditions optionally available. Contact factory for fluid handling capabilities.

Agency Approvals

FM, FMc

T4 Rated (System approval)

ATEX

IEC Ex d IIC

CE Mark, CRN, PED

RoHs (The control circuit and terminal board are in compliance with Directive 2002/95/EC)

Shipping Weight (approximate)

Integral: 8 lb [3.6 kg]

Remote: 13 lb [5.9 kg]

INTENTIONALLY LEFT BLANK

2 INSTALLATION

Receiving/Inspection

- Unpack carefully.
- Verify that all items in the packing list are received and are correct.
- Inspect all instruments for damage or contaminants prior to installation.

If the above three items are satisfactory, proceed with the installation. If not, then stop and contact a customer service representative.

Packing/Shipping/Returns

These issues are addressed in Appendix E - Customer Service.

Factory Calibration Note

The instrument is factory calibrated to the applications as specified at the time of order. There is no need to perform any verification or calibration steps prior to installing and placing the instrument in service unless the application has been varied.

Pre-Installation Procedure

Warning: Only qualified personnel should install this instrument. Install and follow safety procedures in accordance with the current National Electrical Code. Ensure that power is off during installation. Any instances where power is applied to the instrument will be noted in this manual. Where the instructions call for the use of electrical current, the operator assumes all responsibility for conformance to safety standards and practices.

Caution: The instrument contains electrostatic discharge (ESD) sensitive devices. Use standard ESD precautions when handling the control circuit. See below, for ESD details.

The instrument is not designed for weld-in-place applications. Never weld to a process connection or a structural support.

Damage resulting from moisture penetration of the control circuit or flow element enclosure is not covered by product warranty.

Use Standard ESD Precautions

Use standard ESD precautions when opening an instrument enclosure or handling the control circuit. FCI recommends the use of the following precautions: Use a wrist band or heel strap with a 1 megohm resistor connected to ground. If the instrument is in a shop setting there should be static conductive mats on the work table and floor with a 1 megohm resistor connected to ground. Connect the instrument to ground. Apply antistatic agents to hand tools to be used on the instrument. Keep high static producing items away from the instrument such as non-ESD approved plastic, tape and packing foam.

The above precautions are minimum requirements to be used. The complete use of ESD precautions can be found in the U.S. Department Of Defense Handbook 263.

Prepare or Verify Sensing Element Location

Prepare the process pipe for installation, or inspect the already prepared location to ensure that the instrument will fit into the system. Review the requirement for the supply power and alarm circuit connections.

Verify Dimensions

Verify the instrument's dimensions versus the process location to be sure of a correct fit. Also see Appendix A for dimensions.

Verify Sensing Element Flow Direction and Placement Orientation (Flow Application)

For flow detection, the sensing element surface marked with direction arrows should be oriented parallel to the process flow. The flow can be from either direction.

Mount the sensing element at least 20 diameters downstream and 10 diameters upstream from any bends or interference in the process pipe or duct to achieve the greatest accuracy.

For liquid flow service, the sensing element should be located in the process pipe so that the thermowells are always completely wet.

When mounted in a tee or section of pipe larger than the normal process pipe, position in a vertical run of pipe with flow upward. This will prevent air or gas bubbles from becoming trapped at the sensor assembly.

Vertical positioning with flow downward is only recommended for higher flow rate applications (consult FCI).

Verify Sensing Element Flow Direction and Placement Orientation (Level Application)

If the sensing element is side-mounted on the process vessel, then the surface marked with direction arrows should be vertically oriented.

If the sensing element is top- or bottom-mounted on the process vessel, the orientation of the surface marked with direction arrows does not matter.

Install the Sensing Element

Male NPT Mounting

When mounting the sensing element to the process pipe, it is important that a lubricant/sealant be applied to the male threads of all connections. Be sure to use a lubricant/sealant compatible with the process environment. All connections should be tightened firmly. To avoid leaks, do not overtighten or cross-thread connections. See Figure 2-1 and the appropriate drawings in Appendix A for proper mounting.

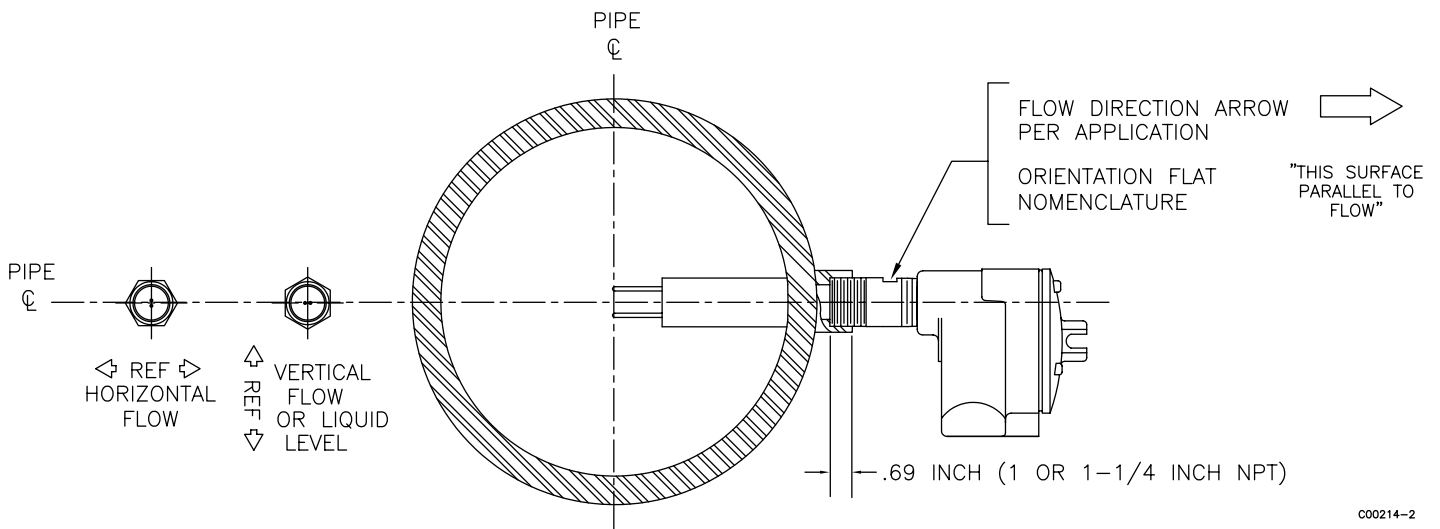

C00214-2

Figure 2-1 NPT Pipe Thread Mount

Flange Mounting

For flange mounted sensing elements, attach the process mating flange with care. The correct orientation of the sensing element must be maintained to ensure optimum performance or calibration. See Figure 2-2 and the appropriate drawings in Appendix A.

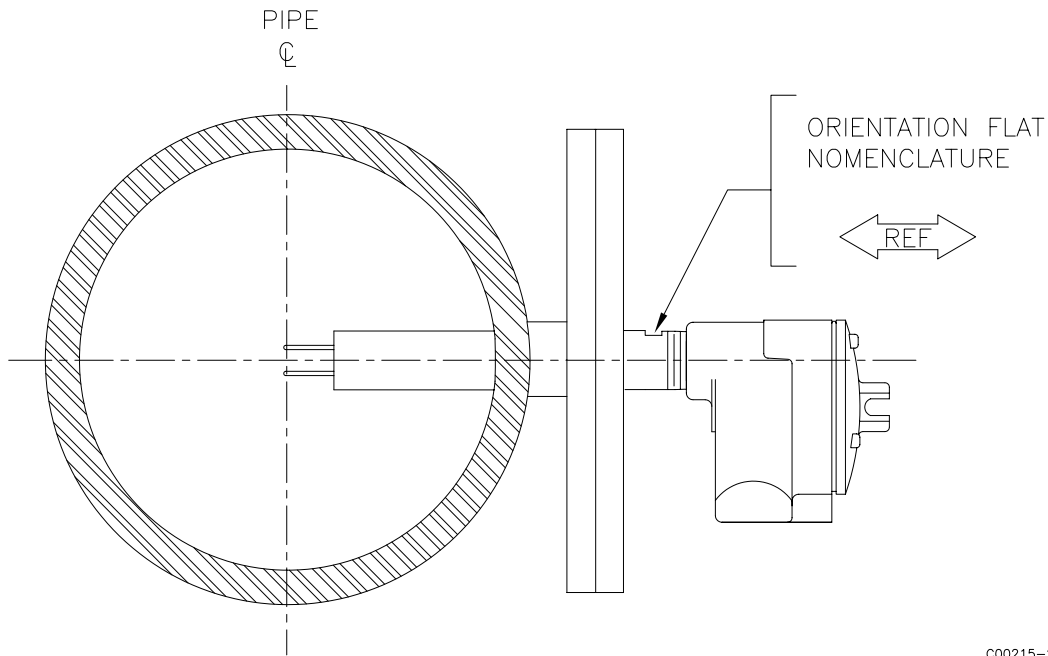

C00215-2

Figure 2-2 Flange Mount

Packing Gland Assembly

Applications involving the use of a packing gland (low or medium pressure) should refer to the drawings in Appendix A for additional detail.

1. Threaded or flanged packing gland mounts are available. The valve assembly with appropriate connections are customer supplied. Follow the male NPT mounting procedure above to attach the pipe thread portion or flange mounting portion as applicable.
2. Tighten the packing nut until the internal packing is tight enough so that the friction fit on the shaft is adequate to prevent leakage but not prevent the shaft from sliding. Position the etched flow arrow parallel with the flow ($\pm 1^\circ$ of level) and position the flow arrow so it is pointing in the direction of the flow.
3. Proceed to insert the probe into the process media line. Use the adjusting nuts on the all-thread to pull the sensing element into proper predetermined depth position.
4. Tighten the opposing lock nuts on the all-threads. Tighten the packing nut another half to full turn until tight (approximately 65 to 85 ft-lbs [88 to 115 N-m] torque).
5. Rotate the split ring locking collar to line up with the connecting strap welded to the packing nut. Tighten the two 1/4-28 hex socket cap screws on the split ring locking collar.

Reverse these steps for removal.

In-line NPT Assembly (FLT93-L)

The body length of the in-line assembly should be verified to be sure the assembly will fit into the process line. See the appropriate drawing in Appendix A to determine the assemblies length. The direction of flow is important for proper operation. There is a flow direction arrow on the in-line pipe that is to point in the direction of flow. See Figure 2-3 for the correct orientation.

If the instrument is a butt weld assembly, be sure to do the following: Remove the circuit board, properly ground the flow element before welding.

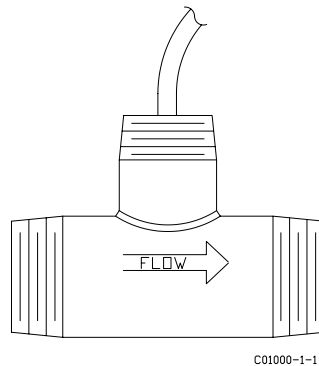

C01000-1-1

Figure 2-3 FLT93-L In-Line Flow Element

Sanitary Assembly (FLT93-C)

The instrument is inserted into the process connection with a removable clamp fittings. The Removable Clamp (RC) sanitary assembly contains a removable clamp connection to the flow element. The Clean-In-Place (CIP) sanitary assembly has the flow element directly welded into the process stand pipe. Otherwise these instruments function exactly the same as an FLT93-F or FLT93-S. See Appendix A for an out-line dimensions of the instruments. Figure 2-4 also shows the sanitary assemblies.

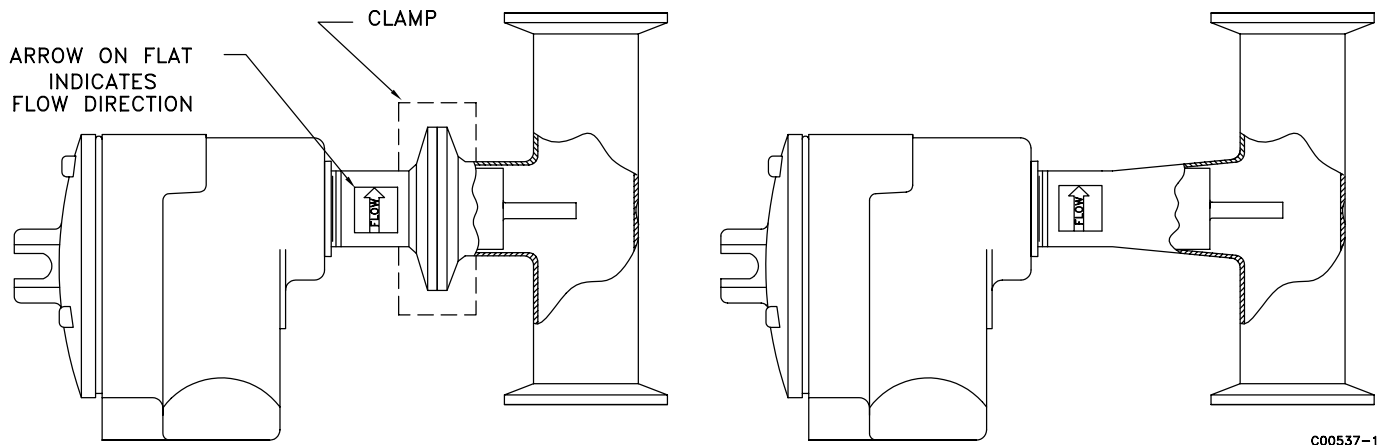

Figure 2-4 FLT93-C Sanitary Flow Elements (RC and CIP)

Install and Wire the Enclosure(s)

Caution: In applications where the sensing element is located in an explosive environment, isolate the conduit before it leaves the environment. A potting Y may be used to provide the isolation.

Pulling wires can cause damage to the control circuit. Therefore, remove the control circuit from the enclosure and use extreme care when pulling wires into the enclosure.

Mount and wire the control circuit either locally or remotely (option) by following the local or remote enclosure procedure below.

Disconnect Device

IEC 61010-1 requires the installation of an external switch or circuit breaker on the 120/220 Vac power source. It is recommended that the switch or the circuit breaker be in close proximity to the flow switch and within easy reach of the operator. The recommended breaker trip value for 120/220 Vac is 3 amps. If 24 Vdc/Vac input power is being used a disconnect switch or breaker is also recommended. Recommended breaker value is 3 amps. All disconnect devices shall be clearly marked for the flow switch.

Minimum Wire Size

Table 2-1 shows the smallest (maximum AWG number) copper wire that is used in the electrical cables. Use a lower gauge of wire for less of a voltage drop. Contact FCI concerning greater distances than those listed in the table. The sensing element cable must be shielded. If the cable is spliced the shield wire must be continued through the splice. If a terminal block is used, the shield must have its own terminal.

Enclosures Covers

All enclosure covers must be in place and securely closed to achieve environmental and safety classifications.

All circular thread-on covers should be tightened about 1/3-turn past hand tight.

Cover locks must be in place and secure if required by a particular approval.

Note: Nitrile (buna-N) O-rings are standard on the circular thread covers; these O-rings have a 250°F (121°C) maximum useage temperature.

A Viton O-ring [400°F (204°C) max. temp.] is available for the thread-on covers; these O-rings have a 500°F (260°C) maximum useage temperature.

To receive a Viton O-ring, provide FCI with the following information:

- Shipping address
- Quantity required
- Desired P/N:
Use P/N 000391-01 for the single conduit port enclosure (Local)
Use P/N 000391-07 for the dual conduit port enclosure (Remote)

Connection	Maximum Distance for AWG					
	10 ft. (3m)	50 ft. (15m)	100 ft. (31m)	250 ft. (76m)	500 ft. (152m)	1000 ft. (305m)
AC/DC Power	22	22	22	20	18	16
Relay (6A)	28	22	20	16	12	10
Flow Element Wires*	22	20	20	18	18	18

* Requires a shielded cable with the shield wire connected to the terminal board only.

Table 2-1 Maximum AWG Number

Cable and Conduit Entry Devices

The cable and conduit entry devices and blanking elements shall be of a certified flameproof type EEx d, suitable for the conditions of use and correctly installed. With the use of conduit entries a sealing device shall be provided immediately on the entrance of the device.

All cable glands and conduit fittings, including conduit plugs, must meet or exceed the area approval where the unit is being installed.

Wiring the Local Enclosure Configuration

Warning: Ensure that all power is off before wiring any circuit.

This procedure is for instruments with the control circuit located in the sensing element enclosure.

1. Remove the Control Circuit from the Terminal Board by loosening the two thumbscrews on top of the transformer bracket. Note: the screws are captive. Note the orientation of the Control Circuit. Grab hold of the transformer bracket where the screws are and unplug the Control Circuit from the Terminal Board by pulling on the transformer bracket.
2. Install conduit between the local enclosure, disconnect device and the power source and monitoring circuit. Provide watertight hardware and apply thread sealant to all connections to prevent water damage.
3. Refer to the "Wiring Input Power" section at the end of this chapter for the available input power configurations. Input power wiring configurations are the same for local and remote enclosure options and also any output relay configuration. Wire in accordance with the system requirements.

NOMINAL RESISTANCE READINGS WITH CONTROL CIRCUIT REMOVED FROM TERMINAL BOARD (AT 80 °F)	
ALARM	RESISTANCE
ACT-COM	1.1K ohm
ACT-REF	2.2K ohm
COM-REF	1.1K ohm
HTR+--HTR-	110-120 ohm FOR FLT93-S 548-620 ohm FOR FLT93-F

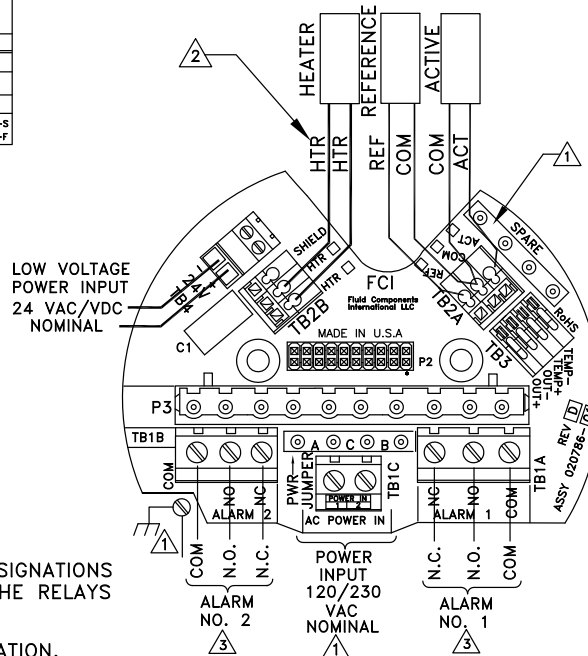

HIGH VOLTAGE POWER INPUT OPTIONS		
VOLTAGE RANGE	PWR JUMPER	WIRE CONNECTIONS
108-132 VAC	RED JUMPER (120V)	TB1C-1: LINE TB1C-2: NEUT
216-240 VAC	BLUE JUMPER (230V)	TB1C-1: LINE TB1C-2: LINE

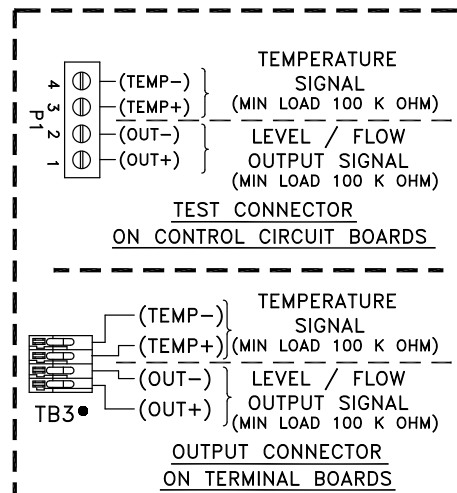

C00979-1-2

- ③ ALARM CONTACT DESIGNATIONS ARE SHOWN WITH THE RELAYS DE-ENERGIZED.
- ② WIRE TAG IDENTIFICATION.
- ① USE CHART TO SELECT THE INPUT VOLTAGE RANGE. USE THE SPARE POSITION FOR UNUSED JUMPER.

Figure 2-5 Local Wiring Diagram

4. When connecting the relay wiring, do so with complete understanding of what the process requires of the instrument. The instrument has dual SPDT or single DPDT relay output contacts dependent on the jumper configuration for each alarm switch point. For the relay terminals and logic, refer to Figure 2-5. Also refer to Table 3-5 and Table 3-6 in Chapter 3 - Operation. Relay contacts are shown with the relays de-energized.

Wiring The Remote Enclosure Configuration

This procedure is for instruments with the control circuit located remotely (remote housing) from the sensing element (local enclosure).

Locate the Remote Hardware Location

Warning: Ensure that all power is off before wiring any circuit.

Drawings in Appendix A show the remote enclosure along with the physical dimensions to properly mount it. Select a location for the remote enclosure within 1000 feet (305 m) of the sensing element NOTE: Maximum cable length is 1000 ft. Pigtail sensing elements can not be located more than 10 feet (3 m) from the enclosure unless the pigtail is extended with the proper size cable listed in Table 2-1. If the cable is extended the cable connections should be located in a junction box with a 6 position terminal block. All 5 conductors and the shield must have their own termination. The remote enclosure should be easily accessible with enough room to open the enclosure cover at any time. Secure the remote enclosure solidly to a vertical surface capable of providing support. Use appropriate hardware to secure the enclosure.

1. Remove the Control Circuit from the Terminal Board by loosening the two thumbscrews on top of the transformer bracket. Note: the screws are captive. Note the orientation of the Control Circuit. Grab hold of the transformer bracket where the screws are and unplug the Control Circuit from the Terminal Board by pulling on the transformer bracket.
2. Install conduit between the remote (electronics) enclosure, disconnect device and the power source\monitoring circuit. Install conduit from the remote electronics enclosure to the local (sensing element) enclosure. Provide watertight hardware and apply thread sealant to all connection to prevent water damage.
3. Refer to the "Wiring Input Power" section at the end of this chapter for the available input power configurations. Input power wiring configurations are the same for local and remote enclosure options and also any output relay configuration.
4. Run a five-conductor, shielded cable from the local enclosure to the remote enclosure. Use Table 2-1 to determine which wire gauge to use (wire between the local and remote enclosures according to Figure 2-6). It is recommended to include a 14AWG wire between the two enclosures connected to the grounding lugs and then to earth ground close to the control circuit housing, with the connection not to exceed 1 ohm.
5. When connecting the relay wiring, do so with complete understanding of what the process requires of the instrument. The instrument has dual SPDT or single DPDT relay output contacts dependent on the jumper configuration for each alarm switch point. For the relay terminals and logic, refer to Figure 2-6. Also refer to Table 3-5 and Table 3-6 in Chapter 3 - Operation. Relay contacts are shown with the relays de-energized. Wire in accordance with the system requirements.

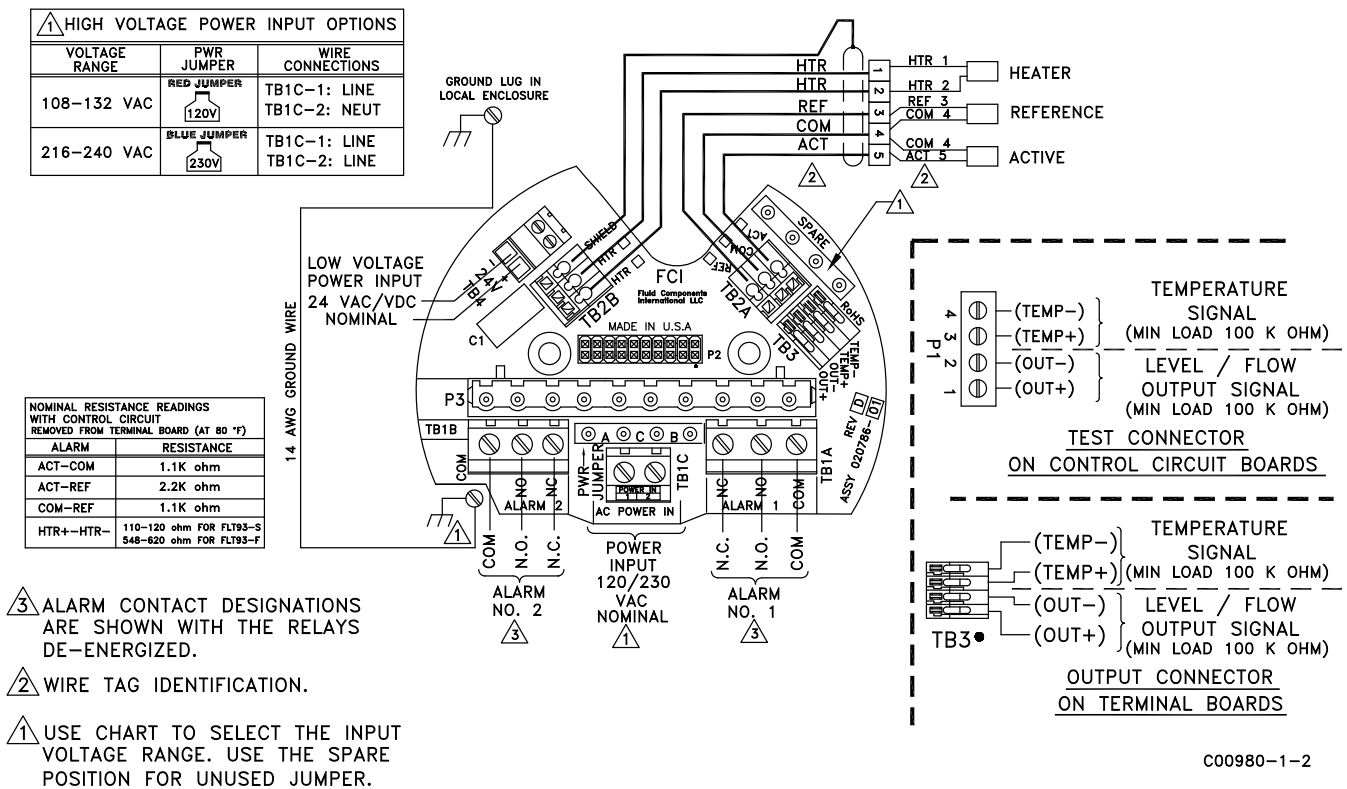

Figure 2-6 Remote Wiring Diagram

Wiring Output Signal Terminals

The primary outputs on the FLT are the relays. Voltage outputs relative to flow/level and temperature are provided on the terminal board at TB3. The signal voltage at positions 1 and 2 represents the process change (non-linear to flow). The signal voltage at positions 3 and 4 is proportional to the temperature at the sensing element. See Figures 2-5 through 2-6. See also Chapter 3 for the physical layout of the control circuit.

Caution: Do not ground terminal 2 of TB3. (Terminal 2 is the negative lead of the process signal.) This terminal is 9 volts above the control circuit ground. The peripheral using this signal must have a differential input.

These voltages can be used by other peripherals with a minimum load of 100K ohms. The terminal block can be wired with between gauge 24 and 20 wire. The maximum recommended length of wire is 100 feet. Shielding is required on any length of cable. The shield must be terminated to earth ground.

To facilitate monitoring the output voltages locally while the instrument is powered, the Control Circuit has test points available at “P1”. These test points can be probed with pointed test leads or hooked on to with test clips (Pomona Mini Grabbers or Easy Hooks). See Figure 3-2 (Operations chapter).

Wiring Input Power

The “Normal AC Line Input Voltages” and the “24 VDC/VAC” are the standard configurations provided and are selectable in the field. Refer to Table 2-2. An option for “Low AC Line Input Voltages” is available.

120 or 230 VAC Input: When wiring the Terminal Board for 120 or 230 VAC, refer to table 2-2, figure 2-7, 2-8 and figure 2-9. Note the required power jumper and the position of the power input wires. The wire gauge range for TB1 is 24 to 12 AWG. Make sure all wires going into one position are properly attached by tugging on each wire individually. Once the Terminal Board is wired, the Control Circuit can be connected to the Terminal Board and secured with the thumbscrews. The Control Circuit does not need to be configured for power input.

24 VDC/VAC: When wiring the Terminal Board for 24 VDC/VAC refer to table 2-2 and figure 2-10. TB4 is a compression screw terminal block that has a wire range of 30 to 12 AWG. Make sure that all wires going into one position are properly attached by tugging each wire individually. When using 24 VDC the polarity does not need to be considered. DC can be connected in either polarity.

C00980-1-2

INPUT POWER WIRING CONFIGURATIONS					
	5208 – 1 X X STANDARD AC LINE INPUT VOLTAGES		5208 – (1 or 2) X X 24 VDC/VAC	5208 – 2 X X LOW AC LINE INPUT VOLTAGES	
Power Jumper	RED	BLUE	NA	RED	BLUE
Main Feed	108 - 132 VAC	216 - 240 VAC	21 - 30 VDC 18 - 24 VAC	93 - 115 VAC	184 - 226 VAC
LINE 1	TB1C-1	TB1C - 1	NA	TB1C-1	TB1C - 1
NEUT / LINE 2	TB1C-2	TB1C-2		TB1C-2	TB1C-2
- 24 VDC/VAC	NA	NA	TB4- 24 DC/AC	NA	NA
+ 24 VDC/VAC	NA	NA	TB4+ 24 DC/AC	NA	NA

Table 2-2 Input Power

RED POWER JUMPER

BLUE POWER JUMPER

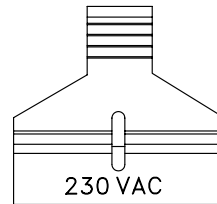
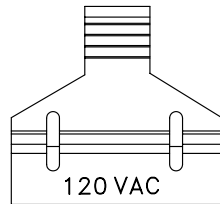

USED FOR INPUT VOLTAGE RANGE 108–132 VAC

USED FOR INPUT VOLTAGE RANGE 216–240 VAC

FACTORY
OPTION
(93–115 VAC)

FACTORY
OPTION
(184–226VAC)

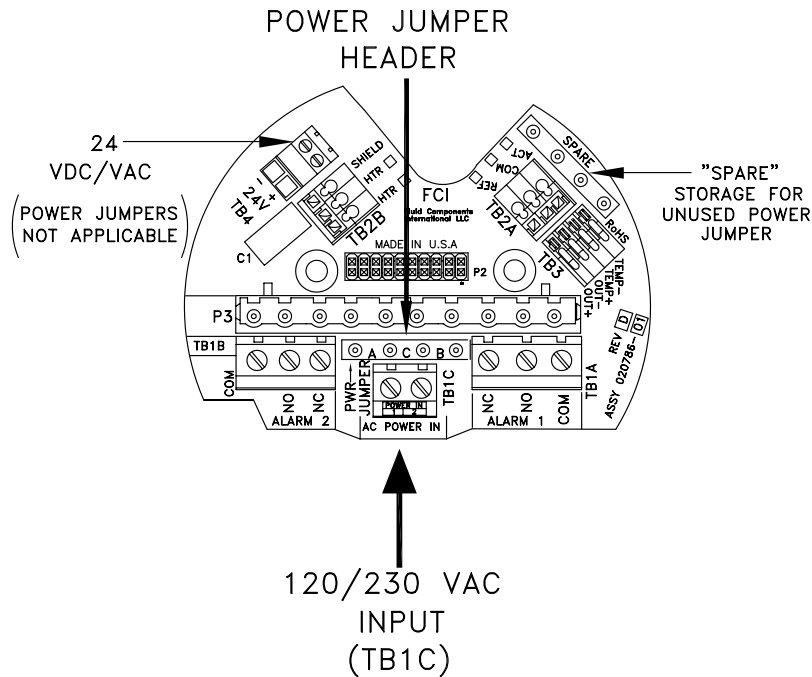

C01071-1-1

Figure 2-7 Power Jumper Diagram

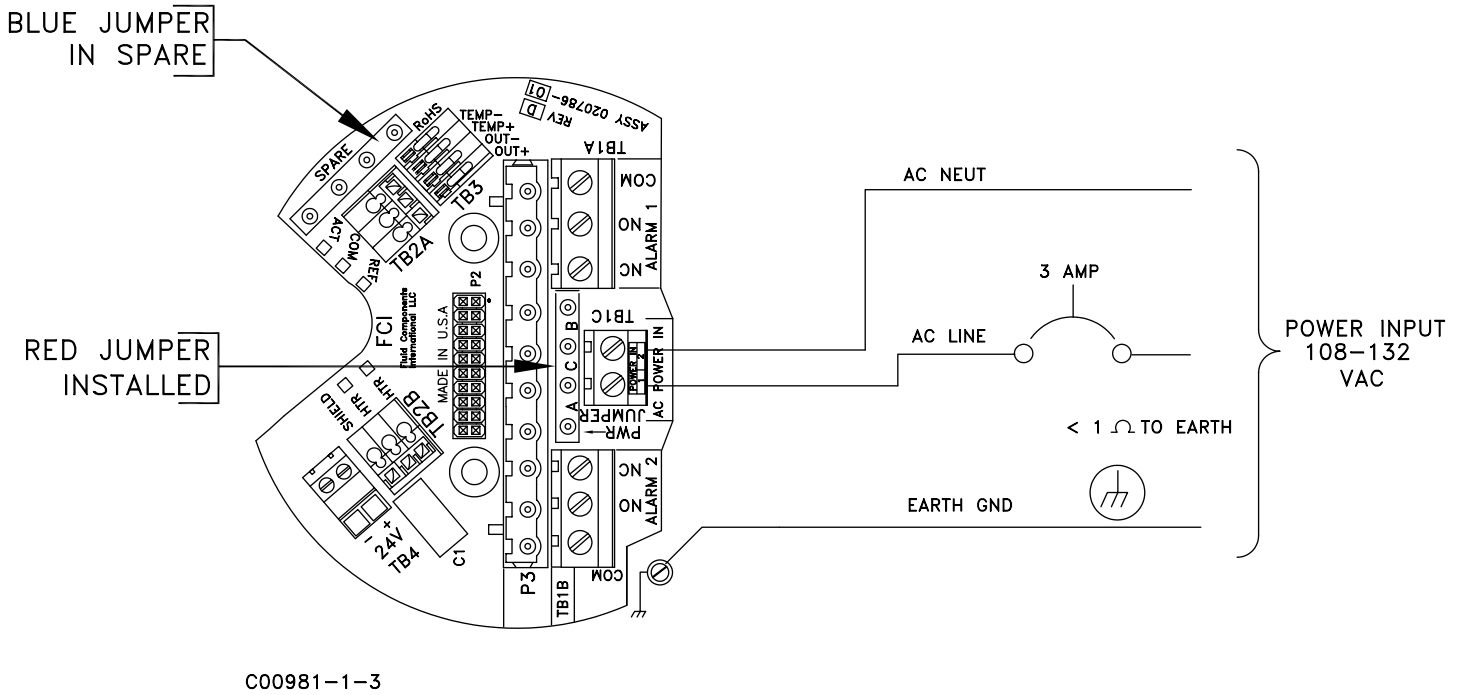

Figure 2-8 120 VAC Input Power Wiring Diagram

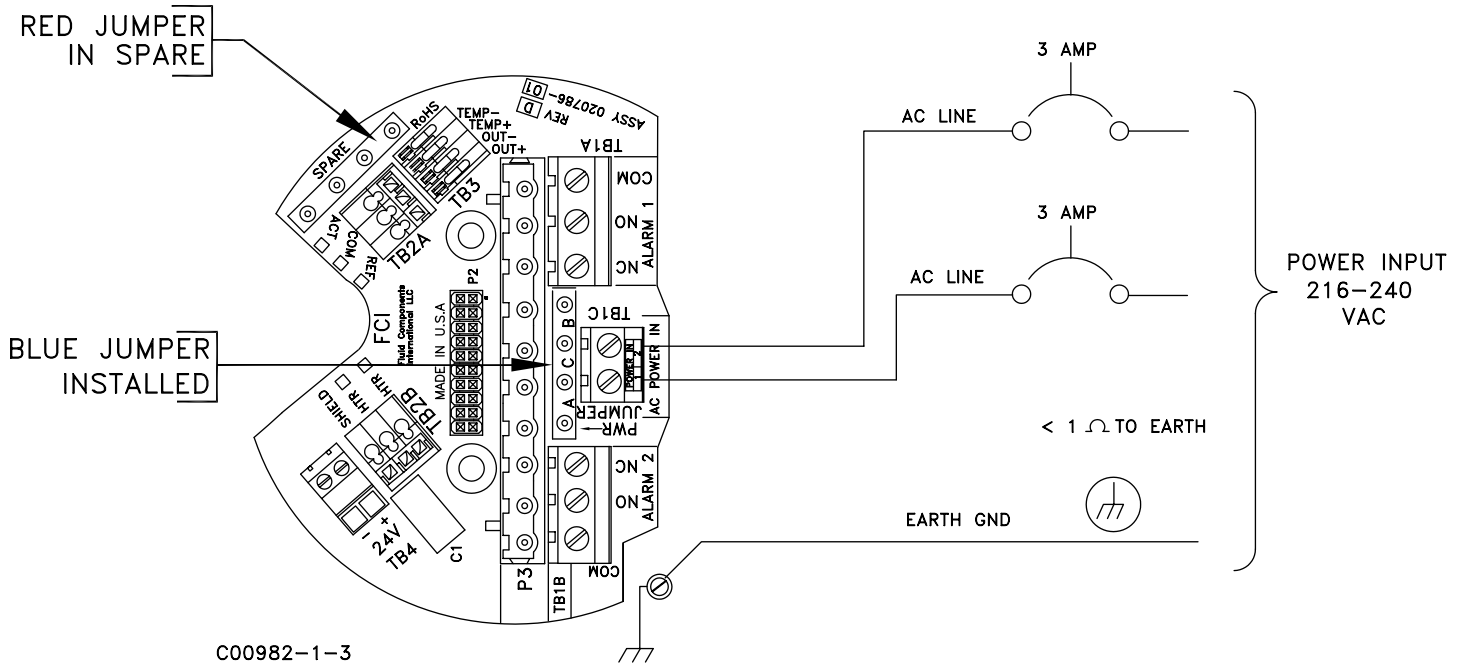
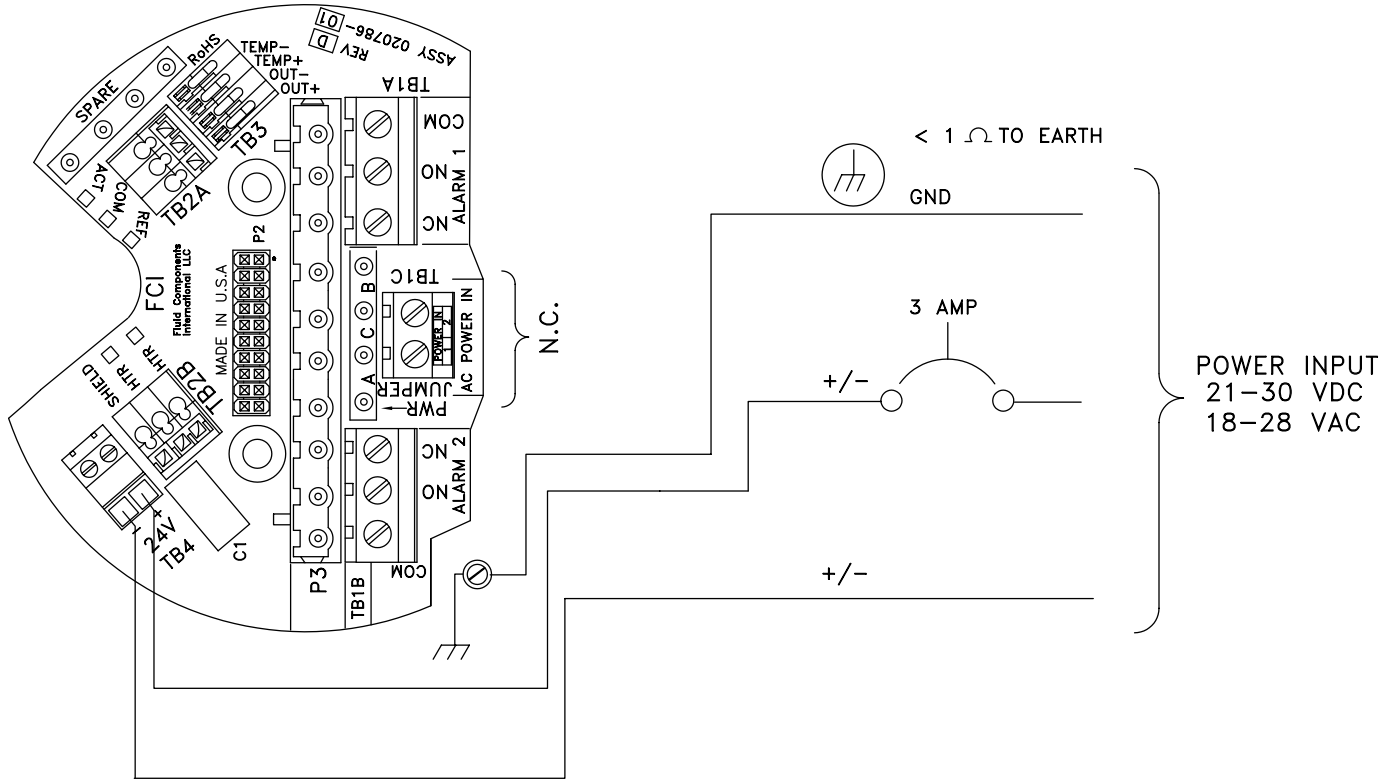

Figure 2-9 230 VAC Input Power Wiring Diagram



C00983-1-3

Figure 2-10 24 VAC/VDC Input Power Wiring Diagram

Figures 2-8, 2-9 and 2-10 can be cross referenced in Appendix A with FCI drawings 022580 [Wiring Diagram FLT93/5208 Integral Control Circuit] and 022581 [Wiring Diagram FLT93/5208 Remote Control Circuit]

3 OPERATION

Caution: The control circuit contains electrostatic discharge (ESD) sensitive devices. Use standard ESD precautions when handling the control circuit. See Chapter 2, Operation, for ESD details.

Factory Default Jumper Configuration

Unless a custom factory setup or calibration is specified, the instrument is delivered in a standard factory configuration. The standard default jumper configuration is shown in Table 3-1.

Heater Power	FLT93-S	0.75 watts for air or liquid level applications. (J13)
	FLT93-F	0.25 watts for air or liquid level applications. (J14)
Number of Alarms	Two (J23). Each alarm has one set of SPDT contacts	
Alarm No. 1 Red LED Set Point Pot, R26	Set to monitor flow or level signals (J20). Relay energized at flow or wet (J27)	
Alarm No. 2 Green LED Set Point Pot, R25	Set to monitor temperature signals (J19). Relay energized below temperature (J25). Set point at approximately: 350°F (121°C) for standard temperature, 500°F (260°C) for medium temperature, 850°F (454°C) for high temperature (FLT93-S Only)	

Table 3-1 Standard Jumper Default Configuration

If the order included custom factory setup and calibration, leave all settings alone. The instrument is ready for service without changes.

If custom factory setup or calibration was not ordered, configure the control circuit using the jumper tables (Tables 3-2 to 3-6) and then follow the set point adjustment section that is appropriate for the application.

Configuration Jumpers

If the order did not specify for the control circuit to be factory configured, the standard configuration can be changed using Figure 3-1 and Table 3-1 through Table 3-6. The factory default configuration is shown as being underlined.

Heater Cut-Off

The 5208 control circuit has a heater cutoff switch that limits the skin temperature of the sensing element to a temperature differential of approximately 150°F (66°C) above the process temperature. In the case where the instrument is used as a gas flow switch, and the heater wattage is set too high, the temperature differential between the RTDs may exceed the usable input range of the control circuit. The usable input range can also be exceeded in the case where the instrument is used in liquid flow applications where the heater wattage is set at the highest value, and the sensing elements go dry. When the temperature differential is less than 150°F (66°C) the heater automatically turns back on. The yellow power indicator LED (DS3) turns on and off with the heater for a visual indication of the heater state. The LED will alternate between on and off until the condition is corrected.

The reason for operating in the above extreme conditions is to insure that the input signal range is at the widest point making the alarm set point adjustment easier to perform. If the heater does cycle the operator may need to use the next lower wattage setting.

In some applications it is desirable to set the heater wattage high, even though the sensing element goes into the heater cutoff mode. An example is when the instrument is used to detect the interface of two liquids. These liquids may have viscosities that will have signals very close to each other. In order to have the maximum signal difference between the signals the heater wattage is set to its maximum. If the sensing element detects a dry condition the control circuit will indicate a heater cutoff condition. The sensing element will not be damaged if it is left dry with the maximum heater wattage. The alarms can be set so one alarm will switch at the interface and one alarm can detect when the element goes dry.

Alarm Set Point Adjustments

Numerical Adjustment Versus Adjustment by Observation

An alarm set point is established using either numerical adjustment or adjustment by observation. The adjustment by observation requires the customer to establish normal process operation and adjust the alarm set point relative to this condition. The numerical approach requires measuring normal and alarm process conditions with a voltmeter and setting up the instrument in the calibrate mode based on these values. The adjustment by observation requires less time to establish the alarm set point. The numerical adjustment requires control of the process as well as additional time to establish the alarm set point. Use the adjustment procedure that is the most appropriate for the application requirement.

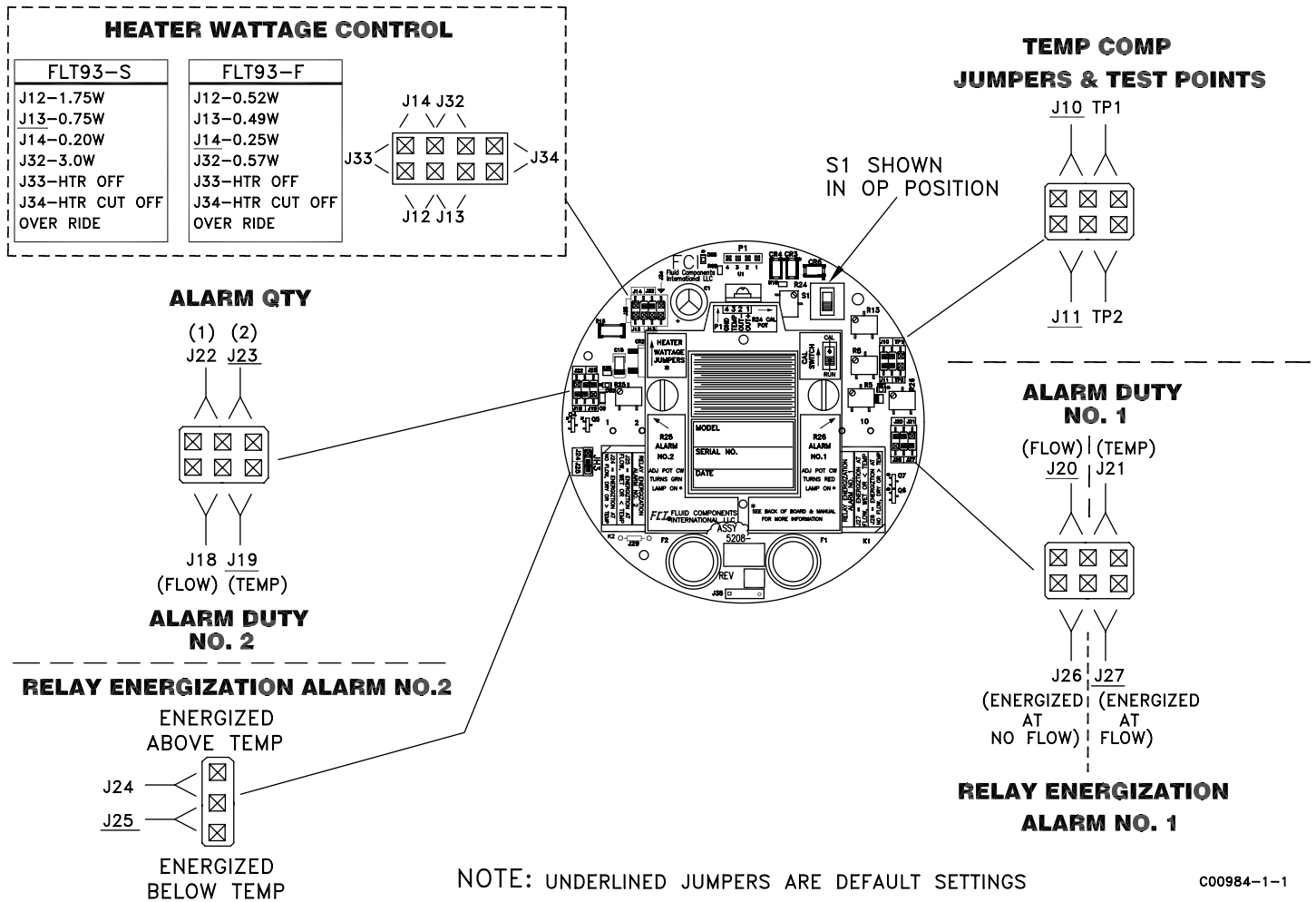

Figure 3-1 5208 Control Circuit Jumper Locations

Jumper	J32	J12	J13	J14	J33
FLT93-F ELEMENT WATTAGE (560 OHM HTR)	0.57 WATTS	0.52 WATTS	0.49 WATTS	0.20 WATTS	OFF
FLT93-S ELEMENT WATTAGE (110 OHM HTR)	3 WATTS	1.75 WATTS	0.75 WATTS	0.27 WATTS	OFF

Table 3-2 Selectable Heater Wattage Control
J13 is standard for FLT93-S and J14 is standard for FLT93-F

Jumper	J13	J14	J33
FLT93-F ELEMENT WATTAGE (560 OHM HTR)	N.A.	0.20 WATTS	OFF
FLT93-S ELEMENT WATTAGE (110 OHM HTR)	0.75 WATTS	N.A.	OFF

Table 3-3 Fixed Heater Wattage Control (T4 Settings)

	FLOW/LEVEL	TEMP
ALARM NO. 1	<u>J20</u>	J21
ALARM NO. 2	J18	<u>J19</u>

Table 3-4 Application

Jumper	ALARM NO. 1
J27	RELAY DE-ENERGIZED WITH LOW FLOW, LOW LEVEL (DRY) OR HIGH TEMPERATURE.
J26	RELAY DE-ENERGIZED WITH HIGH FLOW, HIGH LEVEL (WET) OR LOW TEMPERATURE.
Jumper	ALARM NO. 2
<u>J25</u>	RELAY DE-ENERGIZED WITH LOW FLOW, LOW LEVEL (DRY) OR HIGH TEMPERATURE.
<u>J24</u>	RELAY DE-ENERGIZED WITH HIGH FLOW, HIGH LEVEL (WET) OR LOW TEMPERATURE.

Table 3-5 Relay Energization

<u>J23</u>	DUAL SPDT (ONE RELAY PER ALARM)
J22	SINGLE DPDT (DISABLES ALARM NO. 2)

Table 3-6 Relay Contact Configuration

Numerical Alarm Set Point Adjustment

The control circuit has two mutually exclusive alarms; they are identified as Alarm No. 1 and Alarm No. 2. Each has an alarm set point adjustment potentiometer and LED indicator. Both alarms can be setup for one of three applications; flow, level/interface, or temperature. The following application specific adjustment procedures are generic and can be used for setting either or both alarms. Use Figure 3-2 to help locate the important setup components (potentiometers, LEDs, etc.)

Air/Gas Flow Applications

1. Remove the instrument's enclosure cover.
2. Ensure the configuration jumpers on the control circuit are correct for this application. See Tables 3-2 through 3-6.
3. Make sure the input power is wired correctly (see Chapter 2).
4. Apply power to the instrument. Verify the yellow LED is on and allow the instrument fifteen minutes to warm-up.
5. Verify the mode switch is in the RUN position.
6. Attach a DC voltmeter to the P1 test points with the positive (+) lead to position one (Red) and the negative (-) lead to position two (Blue).
7. Establish the normal process flow condition and allow the signal to stabilize.

Note: The output signal at the P1 test points will vary inversely with changes in the process flow rate. The output signal level is relative to the type of process media being measured and the heater wattage setting. See Figures 3-2 and 3-3.

8. Record the normal flow signal value.

Normal Flow Signal = _____ volts DC

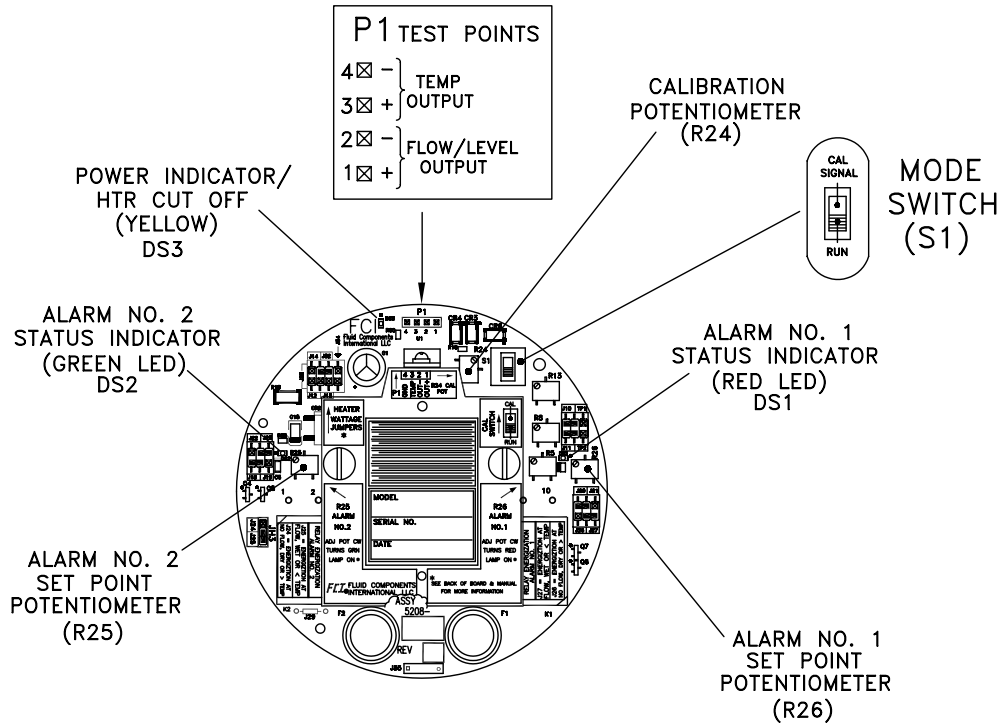

C00985-1-1

Figure 3-2 5208 Control Circuit Component Locations

9. Follow either the Detecting Decreasing Flow or the Detecting Increasing Flow procedure for each flow application alarm.

Detecting Decreasing Flow (low flow alarm)

1. Stop the process flow and allow the signal to stabilize.
2. Record the no-flow signal. (The no-flow signal should be greater than the normal flow signal.)

No-Flow Signal = _____ volts DC

3. Determine the set point by calculating the average of the normal (step 8) and no-flow output signals. (i.e.; If the normal signal is 2.000 volts and the no-flow signal is 5.000 volts, then the calculated set point would be 3.500 volts.)
4. Record this value.

Calculated Set Point = _____ volts DC

Note: The calculated set point must be at least 0.050 volts greater than the normal signal to ensure that the alarm will reset.

5. Slide the mode switch to the CALIBRATE position.
6. Adjust the calibrate potentiometer (R24) until the voltmeter equals the calculated set point.
7. For the appropriate alarm, determine whether the status LED is on or off (red for No. 1 or green for No. 2). If the LED is off, turn the set point adjustment potentiometer (R26 for alarm No. 1 or R25 for alarm No.2) slowly clockwise just until the LED turns on.

OR

If the LED is on, turn the set point adjustment potentiometer (R26 for alarm No. 1 or R25 for alarm No. 2) counterclockwise until the LED turns off and then slowly clockwise just until the LED turns on.

8. If this is the only flow application alarm to be setup, then skip to the Continue With the Air/Gas Flow Procedure.

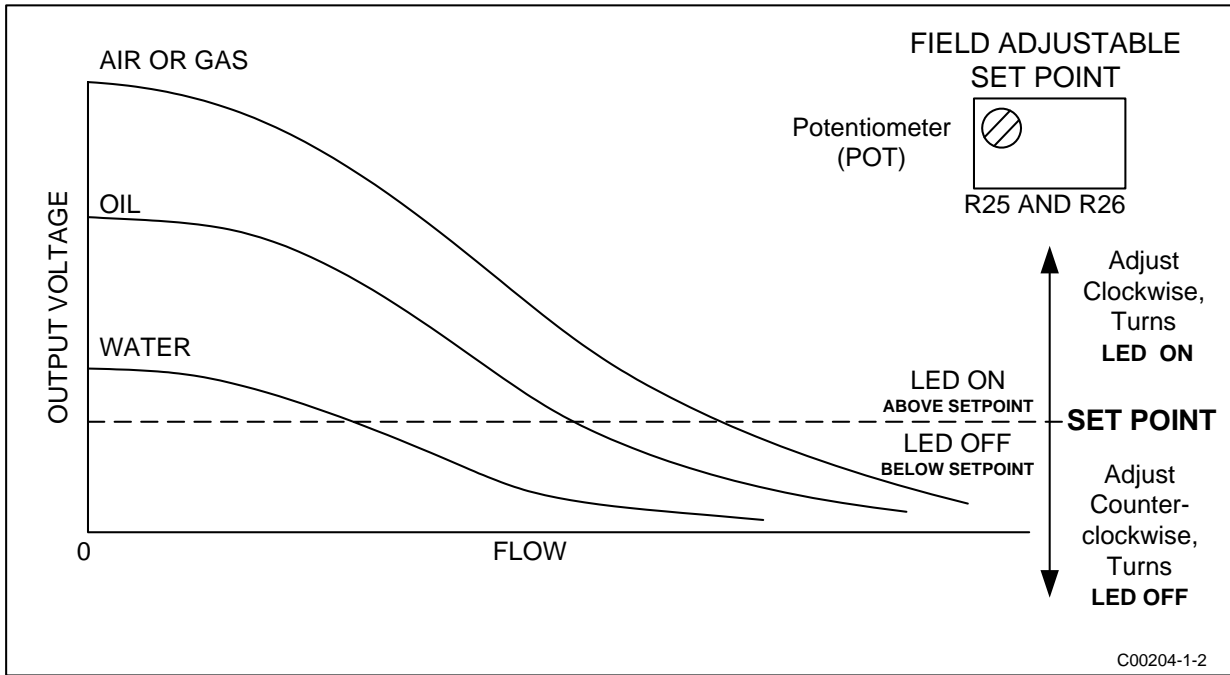

Figure 3-3 Flow Application Signal Output

Detecting Increasing Flow (high flow alarm)

1. Establish the excessive process flow condition and allow the signal to stabilize.
2. Record the high flow signal. (The high flow signal should be less than the normal flow signal.)

High Flow Signal = _____ volts DC

3. Determine the set point by calculating the average of the normal (step 8, page 17 - Air/Gas Flow Application) and high flow output signals. (i.e., If the normal signal is 2.000 volts and the high flow signal is 1.000 volts, then the calculated set point would be 1.500 volts.)
4. Record this value.

Calculated Set Point = _____ volts DC

Note: The calculated set point must be at least 0.50 volts less than the normal signal to ensure that the alarm will reset.

5. Slide the mode switch to the CALIBRATE position.
6. Adjust the calibrate potentiometer (R24) until the voltmeter equals the calculated set point.
7. For the appropriate alarm, determine whether the status LED is on or off (red for No. 1 or green for No. 2).
If the LED is on, turn the set point adjustment potentiometer (R26 for alarm No. 1 or R25 for alarm No. 2) slowly counterclockwise just until the LED turns off.

OR

If the LED is off, turn the set point adjustment potentiometer (R26 for alarm No. 1 or R25 for alarm No. 2) clockwise until the LED turns on and then slowly counterclockwise just until the LED turns off.

Continue With the Air/Gas Flow Procedure

1. Slide the mode switch to the RUN position.
2. Establish the normal process flow condition. For low-flow alarm setups, the status LED should be off. For high flow alarm setups, the status LED should be on.
3. Establish the process alarm condition and monitor the voltmeter display.
4. When the output signal passes through the calculated set point value, the status LED should turn on for low-flow alarms, off for high flow alarms, and the relay contacts should change state.

5. Reestablish the normal process flow condition. Both the LED and the relay contacts should reset.
6. Disconnect the voltmeter from P1.
7. Replace the enclosure cover.

Note: The alarm can be set for a specific flow rate. Follow the Air/Gas Flow Application procedure up to step 7 except establish the specific flow rate rather than the normal flow. The output signal will be the set point value. Determine whether the alarm should actuate with decreasing or increasing flow and skip to the appropriate step 4 in Detecting Decreasing Flow or Detecting Increasing Flow, respectfully. Enter the specific flow rate value as the set point. Then follow the Continue With the Air / Gas Flow Procedure steps.

The relay logic default configuration is set for the relay coil to be de-energized when the flow signal voltage is greater than the set point value. (i.e., Assume that the normal process flow condition has been established. In this state, the relay coil will be energized if the alarm has been set for low-flow detection and de-energized if the alarm has been set for high flow detection.) A recommendation is to have the relay coils energized when the process condition is normal. This will enable the alarm to close or open the contacts in case of a power failure.

Wet/Dry Liquid Level Applications

1. Remove the instrument's enclosure cover.
2. Ensure the configuration jumpers on the control circuit are correct for this application. See Tables 3-2 through 3-6.
3. Make sure the input power is wired correctly (see Chapter 2).
4. Apply power to the instrument. Verify the yellow LED is on and allow the instrument fifteen minutes to warm-up.
5. Verify the mode switch is in the RUN position.
6. Attach a DC voltmeter to P1 with the positive (+) lead to position one (Red) and the negative (-) lead to position two (Blue).
7. Raise the process fluid level so the sensing element is wet.
8. Allow the output signal to stabilize and record the wet condition value.

Wet Condition Signal = _____ volts DC

Note: The output signal at P1 is relative to the type of process media detected. See Figure 3-4.

9. Lower the process fluid level so the sensing element is dry.

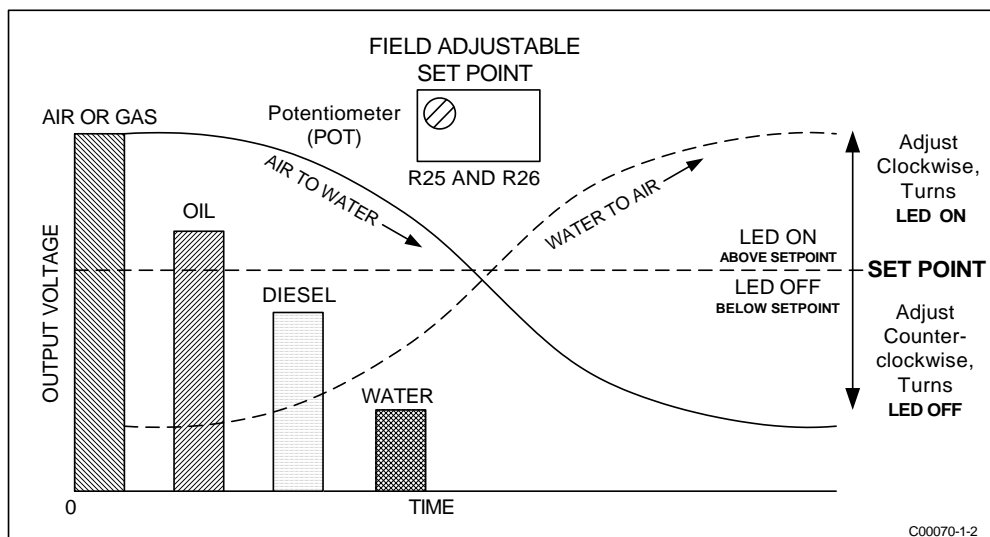

Figure 3-4. Level Application Signal Output

10. Allow the output signal to stabilize and record the dry condition value. (The dry signal should be greater than the wet signal.)

Dry Condition Signal = _____ volts DC

11. Determine the set point by calculating the average of the wet and dry output signals. (i.e., the wet signal is 0.200 volts and the dry signal is 4.000 volts, then the calculated set point would be 2.300 volts.)
12. Record this value.

Calculated Set Point = _____ volts DC

Note: The calculated set point must be at least 0.030 volts greater than the wet signal and 0.040 volts less than the dry signal to ensure that the alarm will reset.

13. Slide the mode switch to the CALIBRATE position.
14. Adjust the calibrate potentiometer (R24) until the voltmeter equals the calculated set point.
15. For the appropriate alarm, determine whether the status LED is on or off (red for No. 1 or green for No. 2).
16. Follow either the Detecting Dry Condition or the Detecting Wet Condition for each level application alarm.

Detecting Dry Condition (low level alarm)

If the status LED is off, turn the set point adjustment potentiometer (R26 for alarm No. 1 or R25 for alarm No. 2) slowly clockwise just until the LED turns on.

OR

If the status LED is on, turn the set point adjustment potentiometer (R26 for alarm No. 1 or R25 for alarm No. 2) counterclockwise until the LED turns off and then slowly clockwise just until the LED turns on.

Detecting Wet Condition (high level alarm)

If the status LED is on, turn the set point adjustment potentiometer (R26 for alarm No. 1 or R25 for alarm No. 2) slowly counterclockwise just until the LED turns off.

OR

If the status LED is off, turn the set point adjustment potentiometer (R26 for alarm No. 1 or R25 for alarm No. 2) clockwise until the LED turns on and then slowly counterclockwise just until the LED turns off.

17. Slide the mode switch to the RUN position. The status LED should be on if the sensing element is dry and off if the sensing element is wet.
18. Monitor the voltmeter display while raising or lowering the process fluid level. When the output signal passes through the set point, the status LED should change states and the relay contacts should change state.
19. Reestablish the normal level condition. Both the LED and relay contacts should reset.
20. Disconnect the voltmeter from P1.
21. Replace the enclosure cover.

Note: The relay logic default configuration is set for the relay coil to be de-energized when the level signal is greater than the set point value. (i.e., The relay coil will be de-energized when the sensing element is dry.) A recommendation is to have the relay coils energized when the process condition is normal. This will enable the alarm to close or open the contacts in case of a power failure.

Liquid Flow Applications

1. Remove the instrument's enclosure cover.
2. Make sure the input power is wired correctly (see Chapter 2).
3. As necessary, set the following control circuit configuration jumpers. See Tables 3-2 through 3-6.
Application: J20 or J18 (Flow/Level) for alarm No. 1 or No. 2, respectively.
Heater Power: J32 (3 watts for FLT93-S or 0.57 watts for FLT93-F).

4. Apply power to the instrument. Verify the yellow LED is on. Allow the instrument fifteen minutes to warm-up.
5. Verify the mode switch is in the RUN position.
6. Attach a DC voltmeter to P1 connector with the positive (+) lead to position one (Red) and the negative (-) lead to position two (Blue).

Note: The output signal at connector P1 will vary inversely with changes in the process flow rate. The output signal level is also relative to the type of process media being measured. See Figure 3-3.

7. Establish the normal process flow condition and allow the signal to stabilize.
8. Record the normal flow signal value.

Normal Flow Signal = _____ volts DC

9. Follow either the Detecting Decreasing Flow or Detecting Increasing Flow procedure for each Liquid flow application alarm.

Detecting Decreasing Flow (low flow alarm)

1. Stop the process flow and allow the signal to stabilize.
2. Record the no-flow signal. (The no-flow signal should be greater than the normal flow signal.)

No-Flow Signal = _____ volts DC

3. Determine the set point by calculating the average of the normal and no-flow output signals. (i.e.; If the normal signal is 0.080 volts and the no-flow signal is 0.300 volts, then the calculated set point would be 0.190 volts.)
4. Record this value.

Calculated Set Point = _____ volts DC

Note: The calculated set point must be at least 0.050 volts greater than the normal signal to ensure that the alarm will reset.

5. Slide the mode switch to the CALIBRATE position.
6. Adjust the calibrate potentiometer (R24) until the voltmeter equals the calculated set point.
7. For the appropriate alarm, determine whether the status LED is on or off (red for No. 1 or green for No. 2).

If the LED is off, turn the set point adjustment potentiometer (R26 for alarm No. 1 or R25 for alarm No. 2) slowly clockwise just until the LED turns on.

OR

If the LED is on, turn the set point adjustment potentiometer (R26 for alarm No. 1 or R25 for alarm No. 2) counterclockwise until the LED turns off and then slowly clockwise just until the LED turns on.

8. If this is the only flow application alarm to be setup, then skip to Continue With the Liquid Flow Applications procedure.

Detecting Increasing Flow Rate (high flow alarm)

1. Establish the excessive flow condition and allow the signal to stabilize.
2. Record the high flow signal. (The high flow signal should be less than the normal flow signal.)

High Flow Signal = _____ volts DC

3. Determine the set point by calculating the average of the normal (step 8 - Liquid Flow Applications) and high flow output signals. (i.e.; the normal signal is 0.080 volts and the high flow signal is 0.030 volts, then the calculated set point would be 0.055 volts.)
4. Record this value.

Calculated Set Point = _____ volts DC

Note: The calculated set point must be at least 0.050 volts less than the normal signal to ensure that the alarm will reset.

5. Slide the mode switch to the CALIBRATE position.
6. Adjust the calibrate potentiometer (R24) until the voltmeter equals the calculated set point.
7. For the appropriate alarm, determine whether the status LED is on or off (red for No. 1 or green for No. 2).

If the LED is on, turn the set point adjustment potentiometer (R26 for alarm No. 1 or R25 for alarm No. 2) slowly counterclockwise just until the LED turns off.

OR

If the LED is off, turn the set point adjustment potentiometer (R26 for alarm No. 1 or R25 for alarm No. 2) clockwise until the LED turns on and then slowly counterclockwise just until the LED turns off.

8. Slide the mode switch to the RUN position.
9. Establish the normal process flow condition. For low-flow alarm setups, the status LED should be off. For high flow alarm setups, the status LED should be on.
10. Establish the process alarm condition and monitor the voltmeter display.
11. When the output signal passes through the calculated set point value, the status LED should turn on for low-flow alarms, off for high flow alarms, and the relay contacts should change state.
12. Reestablish the normal process flow condition. Both the LED and the relay contacts should reset.
13. Disconnect the voltmeter from P1.
14. Replace the enclosure cover.

Note: The alarm can be set for a specific flow rate. Follow the Liquid Flow Application procedure up to step 7 except establish the specific flow rate rather than the normal flow. The output signal will be the set point value. Determine whether the alarm should actuate with decreasing or increasing flow and skip to the appropriate step 4 in Detecting Decreasing Flow or Detecting Increasing Flow, respectfully. Enter the specific flow rate value as the set point. Then continue with steps 5 through 14.

The relay logic default configuration is set for the relay coil to be de-energized when the flow signal voltage is greater than the set point value. (i.e., Assume that the normal process flow condition has been established. In this state, the relay coil will be energized if the alarm has been set for low-flow detection and de-energized if the alarm has been set for high flow detection.) A recommendation is to have the relay coils energized when the process condition is normal. This will enable the alarm to close or open the contacts in case of a power failure.

Adjustment by Observation

Note: The control circuit has two mutually exclusive alarms; they are identified as Alarm No. 1 and Alarm No. 2 and each has a set point adjustment potentiometer and LED indicator. Each alarm can be setup for one of three applications: flow, level/interface, or temperature. The following application specific adjustment procedures are generic and can be used for setting either or both alarms. The mode switch must be in the RUN position. Use Figure 3-2 to help locate the adjustment potentiometers and LEDs.

Flow Applications

1. Ensure that the instrument has been properly installed in the pipeline. Fill the pipeline so the sensing element is surrounded by the process medium.
2. Apply power to the instrument and allow fifteen minutes for the sensing element to become active and stabilize.
3. Flow the pipeline at the normal or expected rate. Remove the enclosure cover to allow access to the control circuit to make adjustments.

Detecting Decreasing Flow (low flow alarm)

If the status LED is off, turn the set point adjustment potentiometer clockwise until the LED turns on. With the LED on, slowly turn the potentiometer counterclockwise one turn past the point at which the LED just turns off. The potentiometer may have up to one-quarter turn of hysteresis, therefore, if the mark is overshoot, the procedure should be repeated.

Detecting Increasing Flow (high flow alarm)

If the status LED is on, turn the set point adjustment potentiometer counterclockwise until the LED turns off. With the LED off, slowly turn the potentiometer clockwise one-half turn past the point at which the LED just turns on. The potentiometer may have up to one-quarter turn of hysteresis, therefore, if the mark is overshoot, the procedure should be repeated.

Level Applications

1. Ensure that the instrument has been properly installed in the vessel.
2. Apply power to the instrument and allow fifteen minutes for the sensing element to become active and stabilize.
3. Remove the enclosure cover to allow access to the control circuit to make adjustments.

Detecting Dry Condition (adjustment with sensing element wet)

Verify that the sensing element is wet. If the status LED is off, turn the set point adjustment potentiometer clockwise until the LED turns on. With the LED on, slowly turn the potentiometer counterclockwise one turn past the point at which the LED just turns off. The potentiometer may have up to one-quarter turn of hysteresis, therefore, if the mark is overshoot, the procedure should be repeated.

Detecting Wet Condition (adjustment with sensing element dry)

Caution: Give consideration to the fact that air or gas flowing over the sensing element may decrease the output signal resulting in a false alarm. If the sensing element is exposed to air or gas flow in the dry condition, or where the process media is highly viscous, make set point adjustments in the wet condition only.

Field adjustments made in the dry condition should be performed in the actual service environment or within a condition that approximates that environment. Provision should be made for the worst case condition of air or gas flow on the sensing element. If the status LED is on, turn the set point adjustment potentiometer counterclockwise until the LED turns off. (If the LED cannot be turned off, the instrument must be set in the wet condition.)

With the LED off, slowly turn the potentiometer clockwise 1 turn past the point at which the LED just goes on. The potentiometer may have up to one-quarter turn of hysteresis, therefore, if the mark is overshoot, the procedure should be repeated.

Signal Output for Level Applications

The output signal at P1 is lowest in water and highest in air. See Figure 3-4.

Temperature Applications

For temperature versus voltage values, see Table 3-7 located at the rear of this chapter. These values have an accuracy of $\pm 5^\circ\text{F}$ ($\pm 2.78^\circ\text{C}$). There is also a conversion formula later in this chapter to convert the temperature output voltage to degrees Fahrenheit. If a factory calibration chart was ordered look at the back of this manual. Make sure the serial number of the chart matches the instrument to be adjusted. Remove the instrument's enclosure cover.

1. Remove the instrument's enclosure cover.

Caution: If both alarms are to be used for temperature, then remove the heater control jumper from the heater, control header. The jumper may be stored on the control circuit by plugging it on position J33. Placing the jumper here will not turn on the heater. If one alarm is for temperature and the other is for flow or level, then set the heater power according to the application. Use alarm No. 2 for the temperature alarm. See Table 3-2 or 3-3.

2. Apply power to the instrument. Verify the yellow LED is on. Allow the instrument a fifteen minute warm-up.
3. Verify the mode switch is in the RUN position.
4. Attach a DC voltmeter to P1 with the positive (+) lead to position 3 (Yellow) and the negative (-) lead to position 4 (Black).
5. Establish the normal process temperature condition and allow the signal to stabilize.
6. Record the normal temperature signal value.

Normal Temperature Signal = _____ volts DC

Note: The output signal at connector P1 will vary proportionally with the process temperature.

7. Follow either the Detecting Increasing Temperature or the Detecting Decreasing Temperature procedure for each temperature application alarm.

Detecting Increasing Temperature (high temperature alarm)

1. Slide the mode switch to the CALIBRATE position.
2. Adjust the calibrate potentiometer (R24) until the voltmeter equals the desired temperature signal in Table 3-7.
3. For the appropriate alarm, determine whether the status LED is on or off (red for No. 1 or green for No. 2).

If the LED is off, turn the set point adjustment potentiometer (R26 for alarm No. 1 or R25 for alarm No. 2) slowly clockwise just until the LED turns on.

OR

If the LED is on, turn the set point adjustment potentiometer (R26 for alarm No. 1 or R25 for alarm No. 2) counterclockwise until the LED turns off and then slowly clockwise just until the LED turns on.

If this is the only temperature application alarm to be setup, then skip to the Continue With the Temperature Application procedure.

Detecting Decreasing Temperature (low temperature alarm)

1. Slide the mode switch to the CALIBRATE position.
2. Adjust the calibrate potentiometer (R24) until the voltmeter equals the normal temperature signal.
3. For the appropriate alarm, determine whether the status LED is on or off (red for No. 1 or green for No. 2).

If the LED is on, turn the set point adjustment potentiometer (R26 for alarm No. 1 or R25 for alarm No. 2) slowly counterclockwise just until the LED turns off.

OR

If the LED is off, turn the set point adjustment potentiometer (R26 for alarm No. 1 or R25 for alarm No. 2) clockwise until the LED turns on and then slowly counterclockwise just until the LED turns off.

Continue With the Temperature Applications

1. Slide the mode switch to the RUN position.
2. Establish the normal process temperature condition. For the high temperature alarm setups, the status LED should be off at normal temperatures. For the low temperature alarm setups, the status LED should be on at normal temperatures.
3. Establish the process alarm condition and monitor the voltmeter display.
4. When the output signal passes through the set point value, the status LED should turn on for high temperature alarms, off for low temperature alarms, and the relay contacts should change state.
5. Reestablish the normal process temperature condition. The LED and relay contacts should reset.
6. Disconnect the voltmeter from P1.
7. Replace the enclosure cover.

Note: The relay default configuration is for the relay coil to be de-energized when the temperature signal is greater than the set point value. (i.e., Assume that the normal process temperature condition has been established. In this state, the relay coil will be energized). A recommendation is to have the relay coil energized when the process temperature is normal. This will enable the alarm to close or open the contacts in case of a power failure.

Converting Temp Out Voltage to Temp in Degrees F or Degrees C

This formula is useful when monitoring the temperature output voltage with a data acquisition system where the formula can be used in the program.

Use the following formula to determine what the temperature is in degrees Fahrenheit, if the FLT temperature output voltage is known.

$$y = a + b(x / .0002) + c(x / 0.002)^2$$

Where:

- y = Temperature in Degrees F
- x = FLT Temperature Output Voltage
- a = -409.3253
- b = 0.42224
- c = .00001904

Use the following equation to convert the temperature from degrees Fahrenheit to Celsius:

$$C = (F - 32) \times 5/9$$

0.00385 OHMS/OHMS/°C 1000 OHM PLATINUM SENSORS											
TEMPERATURE VERSUS VOLTAGE OUTPUT, FLT93											
Temp Output Voltage	°F	°C	Temp Output Voltage	°F	°C	Temp Output Voltage	°F	°C	Temp Output Voltage	°F	°C
1.400	-104	-76	1.600	-59	-51	1.800	-14	-25	2.000	32	0
1.405	-103	-75	1.605	-58	-50	1.805	-13	-25	2.005	33	1
1.410	-102	-75	1.610	-57	-49	1.810	-12	-24	2.010	34	1
1.415	-101	-74	1.615	-56	-49	1.815	-10	-24	2.015	35	2
1.420	-100	-73	1.620	-55	-48	1.820	-9	-23	2.020	37	3
1.425	-99	-73	1.625	-54	-48	1.825	-8	-22	2.025	38	3
1.430	-98	-72	1.630	-53	-47	1.830	-7	-22	2.030	39	4
1.435	-97	-71	1.635	-51	-46	1.835	-6	-21	2.035	40	4
1.440	-95	-71	1.640	-50	-46	1.840	-5	-20	2.040	41	5
1.445	-94	-70	1.645	-49	-45	1.845	-4	-20	2.045	42	6
1.450	-93	-70	1.650	-48	-44	1.850	-2	-19	2.050	43	6
1.455	-92	-69	1.655	-47	-44	1.855	-1	-19	2.055	45	7
1.460	-91	-68	1.660	-46	-43	1.860	0	-18	2.060	46	8
1.465	-90	-68	1.665	-45	-43	1.865	1	-17	2.065	47	8
1.470	-89	-67	1.670	-43	-42	1.870	2	-17	2.070	48	9
1.475	-88	-66	1.675	-42	-41	1.875	3	-16	2.075	49	10
1.480	-86	-66	1.680	-41	-41	1.880	4	-15	2.080	50	10
1.485	-85	-65	1.685	-40	-40	1.885	6	-15	2.085	52	11
1.490	-84	-65	1.690	-39	-39	1.890	7	-14	2.090	53	12
1.495	-83	-64	1.695	-38	-39	1.895	8	-13	2.095	54	12
1.500	-82	-63	1.700	-37	-38	1.900	9	-13	2.100	55	13
1.505	-81	-63	1.705	-36	-38	1.905	10	-12	2.105	56	13
1.510	-80	-62	1.710	-34	-37	1.910	11	-12	2.110	57	14
1.515	-79	-61	1.715	-33	-36	1.915	12	-11	2.115	58	15
1.520	-77	-61	1.720	-32	-36	1.920	14	-10	2.120	60	15
1.525	-76	-60	1.725	-31	-35	1.925	15	-10	2.125	61	16
1.530	-75	-60	1.730	-30	-34	1.930	16	-9	2.130	62	17
1.535	-74	-59	1.735	-29	-34	1.935	17	-8	2.135	63	17
1.540	-73	-58	1.740	-28	-33	1.940	18	-8	2.140	64	18
1.545	-72	-58	1.745	-26	-32	1.945	19	-7	2.145	65	19
1.550	-71	-57	1.750	-25	-32	1.950	20	-6	2.150	67	19
1.555	-70	-56	1.755	-24	-31	1.955	22	-6	2.155	68	20
1.560	-68	-56	1.760	-23	-31	1.960	23	-5	2.160	69	20
1.565	-67	-55	1.765	-22	-30	1.965	24	-5	2.165	70	21
1.570	-66	-55	1.770	-21	-29	1.970	25	-4	2.170	71	22
1.575	-65	-54	1.775	-20	-29	1.975	26	-3	2.175	72	22
1.580	-64	-53	1.780	-18	-28	1.980	27	-3	2.180	74	23
1.585	-63	-53	1.785	-17	-27	1.985	28	-2	2.185	75	24
1.590	-62	-52	1.790	-16	-27	1.990	30	-1	2.190	76	24
1.595	-60	-51	1.795	-15	-26	1.995	31	-1	2.195	77	25

Table 3-7. Temperature versus Voltage Output - Page 1

0.00385 OHMS/OHMS/°C 1000 OHM PLATINUM SENSORS											
TEMPERATURE VERSUS VOLTAGE OUTPUT, FLT93											
Temp Output Voltage	°F	°C	Temp Output Voltage	°F	°C	Temp Output Voltage	°F	°C	Temp Output Voltage	°F	°C
2.200	78	26	2.400	125	52	2.600	172	78	2.800	219	104
2.205	79	26	2.405	126	52	2.605	173	78	2.805	220	105
2.210	80	27	2.410	127	53	2.610	174	79	2.810	221	105
2.215	82	28	2.415	128	53	2.615	175	80	2.815	223	106
2.220	83	28	2.420	129	54	2.620	176	80	2.820	224	107
2.225	84	29	2.425	131	55	2.625	178	81	2.825	225	107
2.230	85	30	2.430	132	55	2.630	179	82	2.830	226	108
2.235	86	30	2.435	133	56	2.635	180	82	2.835	227	109
2.240	87	31	2.440	134	57	2.640	181	83	2.840	229	109
2.245	89	31	2.445	135	57	2.645	182	84	2.845	230	110
2.250	90	32	2.450	136	58	2.650	184	84	2.850	231	111
2.255	91	33	2.455	138	59	2.655	185	85	2.855	232	111
2.260	92	33	2.460	139	59	2.660	186	86	2.860	233	112
2.265	93	34	2.465	140	60	2.665	187	86	2.865	235	113
2.270	94	35	2.470	141	61	2.670	188	87	2.870	236	113
2.275	96	35	2.475	142	61	2.675	189	87	2.875	237	114
2.280	97	36	2.480	144	62	2.680	191	88	2.880	238	115
2.285	98	37	2.485	145	63	2.685	192	89	2.885	239	115
2.290	99	37	2.490	146	63	2.690	193	89	2.890	241	116
2.295	100	38	2.495	147	64	2.695	194	90	2.895	242	117
2.300	101	39	2.500	148	65	2.700	195	91	2.900	243	117
2.305	103	39	2.505	149	65	2.705	197	91	2.905	244	118
2.310	104	40	2.510	151	66	2.710	198	92	2.910	245	119
2.315	105	41	2.515	152	67	2.715	199	93	2.915	247	119
2.320	106	41	2.520	153	67	2.720	200	93	2.920	248	120
2.325	107	42	2.525	154	68	2.725	201	94	2.925	249	121
2.330	108	42	2.530	155	68	2.730	202	95	2.930	250	121
2.335	110	43	2.535	156	69	2.735	204	95	2.935	251	122
2.340	111	44	2.540	158	70	2.740	205	96	2.940	253	123
2.345	112	44	2.545	159	70	2.745	206	97	2.945	254	123
2.350	113	45	2.550	160	71	2.750	207	97	2.950	255	124
2.355	114	46	2.555	161	72	2.755	208	98	2.955	256	124
2.360	115	46	2.560	162	72	2.760	210	99	2.960	257	125
2.365	117	47	2.565	164	73	2.765	211	99	2.965	258	126
2.370	118	48	2.570	165	74	2.770	212	100	2.970	260	126
2.375	119	48	2.575	166	74	2.775	213	101	2.975	261	127
2.380	120	49	2.580	167	75	2.780	214	101	2.980	262	128
2.385	121	50	2.585	168	76	2.785	216	102	2.985	263	128
2.390	122	50	2.590	169	76	2.790	217	103	2.990	264	129
2.395	124	51	2.595	171	77	2.795	218	103	2.995	266	130

Table 3-7. Temperature versus Voltage Output - Page 2

0.00385 OHMS/OHMS/°C 1000 OHM PLATINUM SENSORS											
TEMPERATURE VERSUS VOLTAGE OUTPUT, FLT93											
Temp Output Voltage	°F	°C	Temp Output Voltage	°F	°C	Temp Output Voltage	°F	°C	Temp Output Voltage	°F	°C
3.000	267	130	3.200	315	157	3.400	363	184	3.600	412	211
3.005	268	131	3.205	316	158	3.405	365	185	3.605	414	212
3.010	269	132	3.210	317	159	3.410	366	186	3.610	415	213
3.015	270	132	3.215	319	159	3.415	367	186	3.615	416	213
3.020	272	133	3.220	320	160	3.420	368	187	3.620	417	214
3.025	273	134	3.225	321	161	3.425	370	188	3.625	419	215
3.030	274	134	3.230	322	161	3.430	371	188	3.630	420	215
3.035	275	135	3.235	323	162	3.435	372	189	3.635	421	216
3.040	276	136	3.240	325	163	3.440	373	190	3.640	422	217
3.045	278	136	3.245	326	163	3.445	374	190	3.645	423	217
3.050	279	137	3.250	327	164	3.450	376	191	3.650	425	218
3.055	280	138	3.255	328	165	3.455	377	192	3.655	426	219
3.060	281	138	3.260	330	165	3.460	378	192	3.660	427	220
3.065	282	139	3.265	331	166	3.465	379	193	3.665	428	220
3.070	284	140	3.270	332	167	3.470	381	194	3.670	430	221
3.075	285	140	3.275	333	167	3.475	382	194	3.675	431	222
3.080	286	141	3.280	334	168	3.480	383	195	3.680	432	222
3.085	287	142	3.285	336	169	3.485	384	196	3.685	433	223
3.090	288	142	3.290	337	169	3.490	385	196	3.690	435	224
3.095	290	143	3.295	338	170	3.495	387	197	3.695	436	224
3.100	291	144	3.300	339	171	3.500	388	198	3.700	437	225
3.105	292	144	3.305	340	171	3.505	389	198	3.705	438	226
3.110	293	145	3.310	342	172	3.510	390	199	3.710	439	226
3.115	294	146	3.315	343	173	3.515	392	200	3.715	441	227
3.120	296	146	3.320	344	173	3.520	393	200	3.720	442	228
3.125	297	147	3.325	345	174	3.525	394	201	3.725	443	228
3.130	298	148	3.330	346	175	3.530	395	202	3.730	444	229
3.135	299	149	3.335	348	175	3.535	396	202	3.735	446	230
3.140	301	149	3.340	349	176	3.540	398	203	3.740	447	230
3.145	302	150	3.345	350	177	3.545	399	204	3.745	448	231
3.150	303	151	3.350	351	177	3.550	400	205	3.750	449	232
3.155	304	151	3.355	353	178	3.555	401	205	3.755	451	233
3.160	305	152	3.360	354	179	3.560	403	206	3.760	452	233
3.165	307	153	3.365	355	179	3.565	404	207	3.765	453	234
3.170	308	153	3.370	356	180	3.570	405	207	3.770	454	235
3.175	309	154	3.375	357	181	3.575	406	208	3.775	455	235
3.180	310	155	3.380	359	181	3.580	407	209	3.780	457	236
3.185	311	155	3.385	360	182	3.585	409	209	3.785	458	237
3.190	313	156	3.390	361	183	3.590	410	210	3.790	459	237
3.195	314	157	3.395	362	183	3.595	411	211	3.795	460	238

Table 3-7. Temperature versus Voltage Output - Page 3

0.00385 OHMS/OHMS/°C 1000 OHM PLATINUM SENSORS											
TEMPERATURE VERSUS VOLTAGE OUTPUT, FLT93											
Temp Output Voltage	°F	°C	Temp Output Voltage	°F	°C	Temp Output Voltage	°F	°C	Temp Output Voltage	°F	°C
3.800	462	239	4.000	511	266	4.200	561	294	4.400	612	322
3.805	463	239	4.005	513	267	4.205	563	295	4.405	613	323
3.810	464	240	4.010	514	268	4.210	564	295	4.410	614	323
3.815	465	241	4.015	515	268	4.215	565	296	4.415	616	324
3.820	467	241	4.020	516	269	4.220	566	297	4.420	617	325
3.825	468	242	4.025	518	270	4.225	568	298	4.425	618	326
3.830	469	243	4.030	519	270	4.230	569	298	4.430	619	326
3.835	470	244	4.035	520	271	4.235	570	299	4.435	621	327
3.840	472	244	4.040	521	272	4.240	571	300	4.440	622	328
3.845	473	245	4.045	523	273	4.245	573	300	4.445	623	328
3.850	474	246	4.050	524	273	4.250	574	301	4.450	624	329
3.855	475	246	4.055	525	274	4.255	575	302	4.455	626	330
3.860	477	247	4.060	526	275	4.260	576	302	4.460	627	331
3.865	478	248	4.065	528	275	4.265	578	303	4.465	628	331
3.870	479	248	4.070	529	276	4.270	579	304	4.470	629	332
3.875	480	249	4.075	530	277	4.275	580	305	4.475	631	333
3.880	481	250	4.080	531	277	4.280	581	305	4.480	632	333
3.885	483	250	4.085	533	278	4.285	583	306	4.485	633	334
3.890	484	251	4.090	534	279	4.290	584	307	4.490	635	335
3.895	485	252	4.095	535	279	4.295	585	307	4.495	636	335
3.900	486	252	4.100	536	280	4.300	586	308	4.500	637	336
3.905	488	253	4.105	538	281	4.305	588	309	4.505	638	337
3.910	489	254	4.110	539	282	4.310	589	309	4.510	640	338
3.915	490	255	4.115	540	282	4.315	590	310	4.515	641	338
3.920	491	255	4.120	541	283	4.320	592	311	4.520	642	339
3.925	493	256	4.125	543	284	4.325	593	312	4.525	643	340
3.930	494	257	4.130	544	284	4.330	594	312	4.530	645	340
3.935	495	257	4.135	545	285	4.335	595	313	4.535	646	341
3.940	496	258	4.140	546	286	4.340	597	314	4.540	647	342
3.945	498	259	4.145	548	286	4.345	598	314	4.545	649	343
3.950	499	259	4.150	549	287	4.350	599	315	4.550	650	343
3.955	500	260	4.155	550	288	4.355	600	316	4.555	651	344
3.960	501	261	4.160	551	288	4.360	602	316	4.560	652	345
3.965	503	261	4.165	553	289	4.365	603	317	4.565	654	345
3.970	504	262	4.170	554	290	4.370	604	318	4.570	655	346
3.975	505	263	4.175	555	291	4.375	605	319	4.575	656	347
3.980	506	264	4.180	556	291	4.380	607	319	4.580	657	347
3.985	508	264	4.185	558	292	4.385	608	320	4.585	659	348
3.990	509	265	4.190	559	293	4.390	609	321	4.590	660	349
3.995	510	266	4.195	560	293	4.395	610	321	4.595	661	350

Table 3-7. Temperature versus Voltage Output - Page 4

0.00385 OHMS/OHMS/°C 1000 OHM PLATINUM SENSORS											
TEMPERATURE VERSUS VOLTAGE OUTPUT, FLT93											
Temp Output Voltage	°F	°C	Temp Output Voltage	°F	°C	Temp Output Voltage	°F	°C	Temp Output Voltage	°F	°C
4.600	663	350	4.800	714	379	5.000	765	407	5.200	817	436
4.605	664	351	4.805	715	379	5.005	767	408	5.205	818	437
4.610	665	352	4.810	716	380	5.010	768	409	5.210	820	438
4.615	666	352	4.815	718	381	5.015	769	410	5.215	821	438
4.620	668	353	4.820	719	382	5.020	770	410	5.220	822	439
4.625	669	354	4.825	720	382	5.025	772	411	5.225	824	440
4.630	670	355	4.830	721	383	5.030	773	412	5.230	825	441
4.635	671	355	4.835	723	384	5.035	774	412	5.235	826	441
4.640	673	356	4.840	724	384	5.040	776	413	5.240	828	442
4.645	674	357	4.845	725	385	5.045	777	414	5.245	829	443
4.650	675	357	4.850	727	386	5.050	778	415	5.250	830	443
4.655	677	358	4.855	728	387	5.055	779	415	5.255	832	444
4.660	678	359	4.860	729	387	5.060	781	416	5.260	833	445
4.665	679	360	4.865	730	388	5.065	782	417	5.265	834	446
4.670	680	360	4.870	732	389	5.070	783	417	5.270	835	446
4.675	682	361	4.875	733	389	5.075	785	418	5.275	837	447
4.680	683	362	4.880	734	390	5.080	786	419	5.280	838	448
4.685	684	362	4.885	736	391	5.085	787	420	5.285	839	449
4.690	686	363	4.890	737	392	5.090	789	420	5.290	841	449
4.695	687	364	4.895	738	392	5.095	790	421	5.295	842	450
4.700	688	364	4.900	739	393	5.100	791	422	5.300	843	451
4.705	689	365	4.905	741	394	5.105	792	422	5.305	845	451
4.710	691	366	4.910	742	394	5.110	794	423	5.310	846	452
4.715	692	367	4.915	743	395	5.115	795	424	5.315	847	453
4.720	693	367	4.920	745	396	5.120	796	425	5.320	849	454
4.725	694	368	4.925	746	397	5.125	798	425	5.325	850	454
4.730	696	369	4.930	747	397	5.130	799	426	5.330	851	455
4.735	697	369	4.935	748	398	5.135	800	427	5.335	852	456
4.740	698	370	4.940	750	399	5.140	802	428	5.340	854	457
4.745	700	371	4.945	751	399	5.145	803	428	5.345	855	457
4.750	701	372	4.950	752	400	5.150	804	429	5.350	856	458
4.755	702	372	4.955	754	401	5.155	805	430	5.355	858	459
4.760	703	373	4.960	755	402	5.160	807	430	5.360	859	459
4.765	705	374	4.965	756	402	5.165	808	431	5.365	860	460
4.770	706	374	4.970	757	403	5.170	809	432	5.370	862	461
4.775	707	375	4.975	759	404	5.175	811	433	5.375	863	462
4.780	709	376	4.980	760	404	5.180	812	433	5.380	864	462
4.785	710	377	4.985	761	405	5.185	813	434	5.385	866	463
4.790	711	377	4.990	763	406	5.190	815	435	5.390	867	464
4.795	712	378	4.995	764	407	5.195	816	435	5.395	868	465

Table 3-7. Temperature versus Voltage Output - Page 5

Fail Safe Alarm Setting

These procedures set the second relay to detect component failure (fail-safe).

Low Flow Alarm Settings

For the low flow fail safe setup the following jumpers are to be installed: J18, J20, J23, J24, J27.

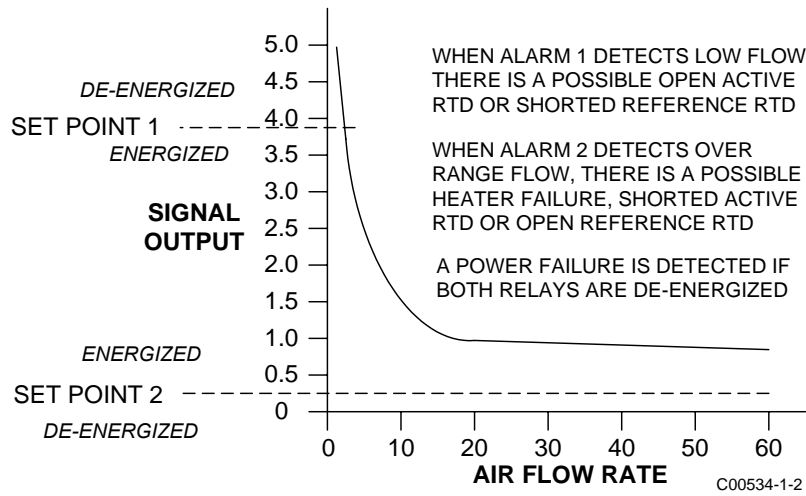

Figure 3-5. Low Flow Fail Safe Alarm

The following information is assumed:

- Relay is de-energized in the ALARM condition.
- Alarm 1 set point is adjusted for desired low flow alarm velocity or signal.
- Alarm 2 set point is adjusted slightly below minimum signal output (over range flow).

High Flow Alarm Settings

For the high flow fail safe setup the following jumpers are to be installed: J18, J20, J23, J25, J26.

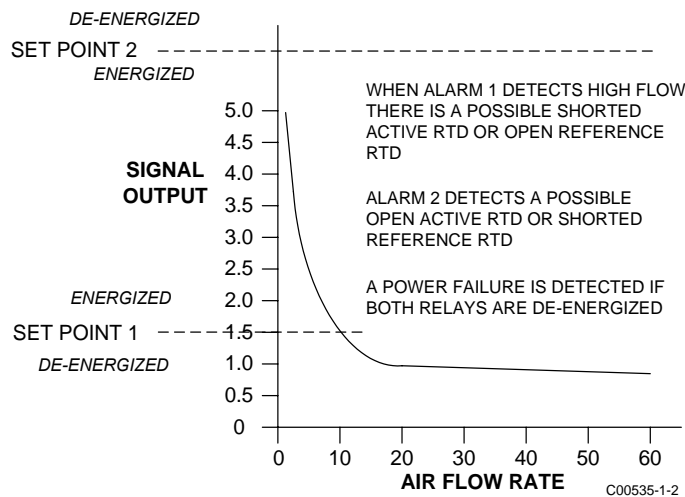

Figure 3-6. High Flow Fail Safe Alarm

The following information is assumed:

- Relay is de-energized in the ALARM condition.
- Alarm 1 set point is adjusted for desired high flow alarm velocity or signal.
- Alarm 2 set point is adjusted above maximum signal output (under range flow not to exceed 7.0 volts).

Low Level Alarm Settings (Sensing Element Normally Wet)

For the low level fail safe setup the following jumpers are to be installed: J18, J20, J23, J24, J27.

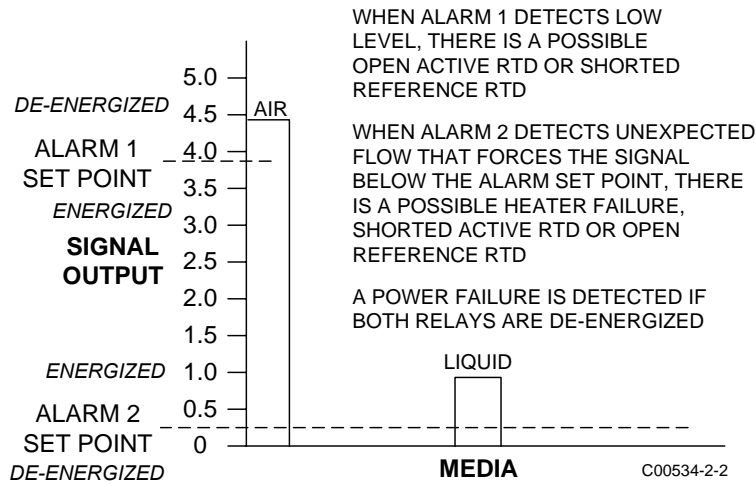

Figure 3-7. Low Level Fail Safe Alarm

The following information is assumed:

Relay is de-energized in the ALARM condition.

Alarm 1 set point is adjusted for the mean value between the air and liquid signals.

Alarm 2 set point is adjusted to approximately half of the liquid signal. (A lower setting might be needed if the liquid is moving.)

High Level Alarm Settings (Sensing Element Normally Dry)

For the high level fail safe setup the following jumpers are to be installed: J18, J20, J23, J25, J26.

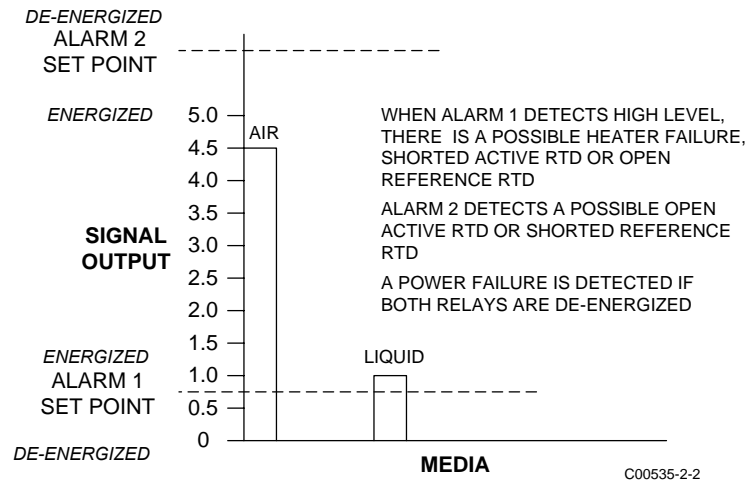

Figure 3-8. High Flow Fail Safe Alarm

The following information is assumed:

Relay is de-energized in the ALARM condition.

Alarm 1 set point is adjusted for the mean value between the air and liquid signals.

Alarm 2 set point is adjusted above maximum signal output for air (not to exceed 7.0 volts).

INTENTIONALLY LEFT BLANK

4 MAINTENANCE

Warning: To avoid hazards to personnel, ensure that all environmental isolation seals are properly maintained.

Caution: The instrument contains electrostatic discharge (ESD) sensitive devices. Use standard ESD precautions when handling the control circuit. See Chapter 2, Operation, for ESD details.

The FCI instrument requires very little maintenance. There are no moving parts or mechanical parts subject to wear in the instrument. The sensor assembly which is exposed to the process media is all stainless steel construction and is only susceptible to chemical attack based on the corrosion relationship of the RTD thermowell material with the process media.

Maintenance

Without detailed knowledge of the environmental parameters of the application surroundings and process media, FCI cannot make specific recommendations for periodic inspection, cleaning, or testing procedures. However, some suggested general guidelines for maintenance steps are offered below. Use operating experience to establish the frequency of each type of maintenance.

Calibration

Periodically verify the calibration of the output and re-calibrate if necessary. See Chapter 3 for instructions.

Electrical Connections

Periodically inspect cable connections on terminal strips and terminal blocks. Verify that terminal connections are tight and in good condition with no sign of corrosion.

Remote Enclosure

Verify that the moisture barriers and seals protecting the electronics in the local and remote enclosures are adequate and that no moisture is entering those enclosures.

Electrical Wiring

FCI recommends occasional inspection of the system's interconnecting cable, power wiring and sensing element wiring on a common sense basis related to the application environment. Periodically the conductors should be inspected for corrosion and the cable insulation checked for signs of deterioration.

Sensing Element Connections

Verify that all seals are performing properly and that there is no leakage of the process media. Check for deterioration of the gaskets and environmental seals used.

Sensing Element Assembly

Periodically remove the sensing element for inspection based on historical evidence of debris, foreign matter, or scale buildup during appropriate plant shutdown schedules and procedures. Check for corrosion, stress cracking, and/or buildup of oxides, salts, or other substances. The thermowells must be free of excessive contaminants and be physically intact. Any debris or residue buildup could cause inaccurate switching. Clean the sensing element with a soft brush and available solvents that are compatible with the instruments wetted metal.

INTENTIONALLY LEFT BLANK

5 TROUBLESHOOTING

Warning: Only qualified personnel should attempt to test this instrument. The operator assumes all responsibilities for safe practices while troubleshooting.

Caution: The control circuit contains electrostatic discharge (ESD) sensitive devices. Use standard ESD precautions when handling the control circuit. See Chapter 2, Operation, for ESD details.

Tools Needed

Digital Multimeter (DMM)
3 Slotted Screwdrivers - 3/32" (2mm); 1/8" (3mm); 1/4" (6mm)
Small phillips head screwdriver

Quick Check

- Verify that the control circuit is seated firmly.
- LED DS3 (yellow LED) should be lit when power is applied and in most cases it should not be blinking.
- Ensure that the jumpers are in the correct position. See Chapter 3 for the correct positions. Check input power.
- Ensure that the CALIBRATE - RUN switch is in the RUN position (switch S1 positioned toward the heat sink).
- If LED DS3 flashes the heater power is set to high for most applications.
- Check any customer supplied fuses or disconnects.
- See the troubleshooting chart in Figure 5-1 at the end of this chapter.

Non-maintenance Observations

At this point, observe the system setup to verify operation. No disassembly or testing is required at this time.

Check Serial Numbers

Verify that the serial number of the sensing element and the control circuit are the same number. The sensing element and the control circuit are a matched set and cannot be operated independently of each other. The exception to this is if a removal and replacement have been done for repair purposes. All calibrations and jumpers must have been done and set.

Check Input Power

Verify that the correct power source is turned on and connected. Verify that the correct power jumper is installed and the power wiring is correct for the application. See Chapter 3 for the correct positions.

Check the Instrument Installation

Review the information on instrument installation in Chapter 2 to verify correct mechanical and electrical installation.

Check for Moisture

Check for moisture on the control circuit or in the sensor, or control circuit enclosure. Moisture on the control circuit may cause intermittent operation.

Check Application Design Requirements

Application design problems may occur with first time application instruments, although the design should also be checked on instruments that have been in operation for some time. If the application design does not match field conditions, errors occur.

1. Review the application design with plant operation personnel and plant engineers.
2. Ensure that plant equipment such as pressure and temperature instruments conform to the actual conditions.
3. Verify operating temperature, operating pressure, line size, and process medium.

If conditions and specifications are satisfactory, then refer to the troubleshooting chart in the back of this chapter for troubleshooting suggestions.

Troubleshooting the Flow Element

Use Tables 5-1 and 5-2 to determine if the flow element is wired correctly or has failed. Turn off the input power to the instrument. Unplug the control circuit from its socket and measure the resistances below from the terminal board.

If the instrument is set up in remote configuration (flow element enclosure separate from the control circuit enclosure), and the ohm readings are incorrect, disconnect the flow element cable at the local (flow element) enclosure. Measure the resistance as shown in Table 5-2. If the resistances are correct then the cable between the enclosures is probably bad or not connected properly (loose, corroded, or connected to the wrong terminals).

For normally dry conditions check for moisture on the sensing element. If a component of the process media is near its saturation temperature it may condense on the sensing element. Place the sensing element where the process media is well above the saturation temperature of any of the process gases.

NOMINAL RESISTANCE READINGS AT THE TERMINAL BOARD @ 80°F PROCESS TEMPERATURE	
TERMINAL NUMBER	RESISTANCE
ACT TO COM	1.1 K OHMS*
ACT TO REF	2.2 K OHMS*
COM TO REF	1.1 K OHMS*
HTR+ TO HTR-	110-120 OHMS FOR FLT93-S 548-620 OHMS FOR FLT93-F

Table 5-1. Resistance at Control Circuit Terminal Board
(See Fig. 5-1 for test points)

NOMINAL RESISTANCE AT LOCAL ENCLOSURE TERMINAL BLOCK	
TERMINAL NO.	RESISTANCE
1 TO 2	110 OHMS FOR FLT93-S 548-620 OHMS FOR FLT93-F
3 TO 4	1.1 K OHMS*
3 TO 5	2.2 K OHMS*
4 TO 5	1.1 K OHMS*
SHIELD CONNECTED TO CONTROL CIRCUIT SOCKET ONLY. NO CONNECTION TO LOCAL ENCLOSURE OR ITS TERMINAL BLOCK **	

Table 5-2. Resistance at Flow Element enclosure Terminal Block (Remote Applications Only)

* Approximate at 80°F process temperature.

** Reference wiring diagrams in the Installation section of the manual.

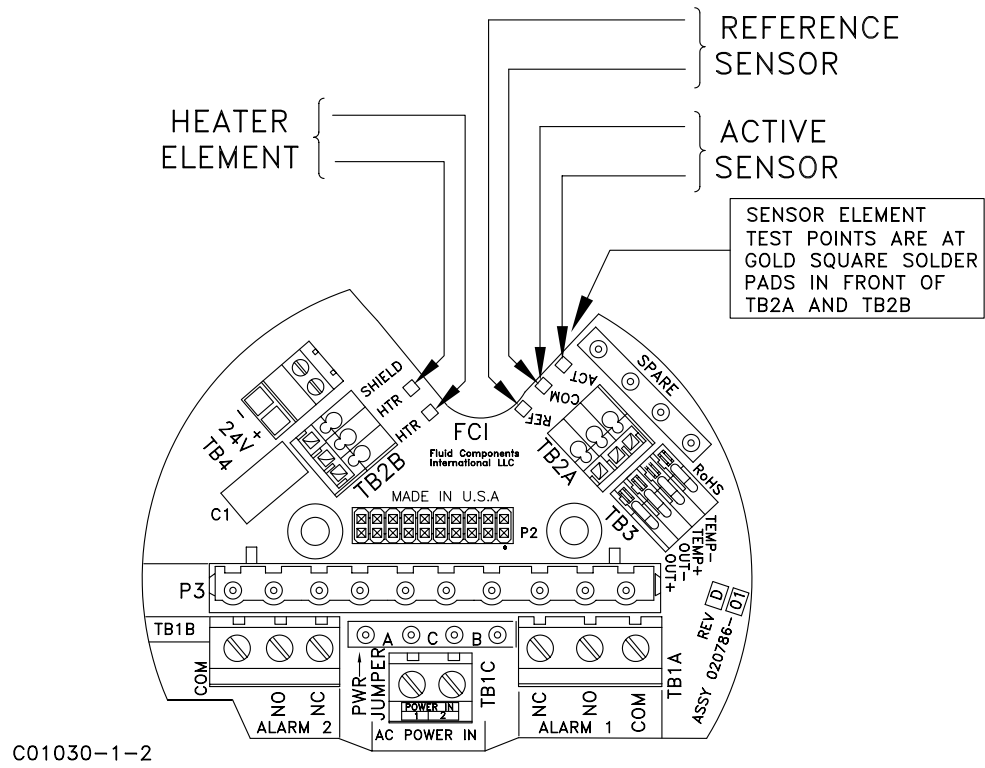

Figure 5-1 Terminal Board, Test Points

Troubleshooting the Control Circuit

1	Is the Yellow Power indicator LED: Dim, Off or Blinking	<p>Yellow LED dim or off With the power applied, measure the 9 volt reference voltage at P1, pins 2 (Blue) to 4 (Black). See Figure 3-2 for the location of P1. The voltage should be 9 volts +/- 2% (8.82 to 9.18v).</p> <p>Not OK: Low Reading: A low reading may indicate incorrect power is being applied. Turn off the power and remove the Control Circuit. <i>Caution: While the power is on, use extreme care when measuring the input voltage.</i> Check the input power wiring on the Terminal Board and make corrections if necessary. Before reinstalling the Control Circuit, apply the input voltage to verify or correct. Check disconnects. Turn off the power and reinstall the Control Circuit. Apply power and re-check the 9 volt reference.</p> <p>Not OK: No Reading: Go to step 2 and check the fuses.</p> <p>OK: If the 9 volt reference measures correctly and the yellow LED is off, refer to the "Troubleshooting the Flow Element" section in this chapter. On remote installations, the interconnect cable may be miswired or a wire may be disconnected. If the flow element resistances are not correct contact the factory. If the sensor is OK then proceed to step 4.</p> <p>Yellow LED Blinking: For Liquid Flow Applications: Line is Dry. Make sure that the line is packed. For Gas Flow Applications: Heater power set too high. Set to a lower value. For Liquid Level Applications: Heater power set too high. Set to lower value. For Liquid Interface Application: In some cases it is necessary to set the heater power to the maximum value to achieve the maximum signal difference between the two liquids. Blinking is okay.</p>
2	Fuse Check	<p>Turn off the power and remove the Control Circuit. For installations using 120/220 Vac, remove F1 and F2. With an ohmmeter, measure the continuity of the fuses. If one or both of the fuses are open, replace and recheck if the Control Circuit functions properly. If the one or both fuses open again, contact the factory. If the fuses are OK but the control circuit does not power up contact the factory.</p> <p>For installations using 24 Vac/Vdc, remove the bottom insulator and locate F3. With an ohmmeter, measure the continuity across the fuses. If the fuse is open, replace and recheck if the Control Circuit functions properly. If fuse opens again, contact the factory. If the fuse is OK but the control circuit does not power up contact the factory.</p>
3	Flow switch not responding	<p>Is the mode switch in the "RUN" position?</p> <p>Is the signal voltage reacting to flow or liquid level movement and is the signal within the usable range of 0-7.0 volts at P1 pin 1(Red) and 2 (Blue)?</p> <p>Not OK: Go to step 4.</p>

<p>4</p>	<p>Signal Voltage Observation</p>	<p>With the power applied, note the position of the Heater wattage control jumper plug and remove it. Place the jumper plug temporarily on position J33. With a voltmeter measure the voltage at P1 pins 1 (Red) and 2 (Blue).</p> <p>a) The voltage is 0 volts +/- 25 mV: OK</p> <p>Reinstall the jumper plug and wait 5 minutes. Go to c) or d) which ever is applicable.</p> <p>b) The voltage is out of tolerance: NOT OK. Make sure the serial numbers from the sensor element and the Control Circuit match. If the serial numbers match then go the "Restoring the Temp Comp Adjustments" procedure in appendix D then go to c) or d) whichever is applicable.</p> <p>c) The voltage is between 0 and 7 volts and changes with flow or level changes: OK.</p> <p>See Step 5 switch point</p> <p>d) The voltage is still about 0 volts: or the voltage is stuck over +/- volts7: or the voltage is negative between 0 and -7 volts and changes with flow or level changes: Not OK. The Sensing element may be miswired or defective. Miswiring is more common on remote installations at the initial installation. Refer to the "Troubleshooting the Flow Element" section in this chapter. On remote installations, the interconnect cable may be miswired or a wire may be disconnected. If the flow element resistances are not correct contact the factory.</p>
<p>5</p>	<p>Alarm Switch</p>	<p>Make sure that the jumpers are set correctly. The related settings are the "Alarm Duty", "Alarm Quantity", and the "Energization". Refer to the charts in chapter 3 or the bottom side of the control circuit.</p> <p>Using the Mode Switch set to Cal, check and record the alarm settings. Compare these settings to the signals generated by the process and make adjustment if necessary. Refer to the Operation chapter for guidelines on setting a switch point in your particular application.</p>

Table 5-3. Trouble Shooting Chart

Spares

FCI recommends an extra control circuit to be kept as a spare. The control circuit part number is 5208-XXX. The dash number can be found on the control circuit, the enclosure and on the ordering paper work. Also recommended is an extra terminal board as a spare, part number 020786-01.

Defective Parts

Before returning any equipment to FCI, please obtain an RA number for authorization, tracking, and repair/replacement instructions. If a return is required, remove defective instrument, replace with spare, calibrate, then return defective instrument to FCI freight prepaid for disposition.

Customer Service

1. In the event of problems or inquiries regarding the instrument, contact the Regional or Country Authorized FCI Field Agent. There is an extensive list of these representatives at the front of this manual.
2. Before contacting the FCI representative, please be sure that all the applicable information is near so that a more effective, efficient and timely response may be provided.
3. Refer to Appendix E for specific Customer Service policy provisions.

INTENTIONALLY LEFT BLANK

APPENDIX A DRAWINGS

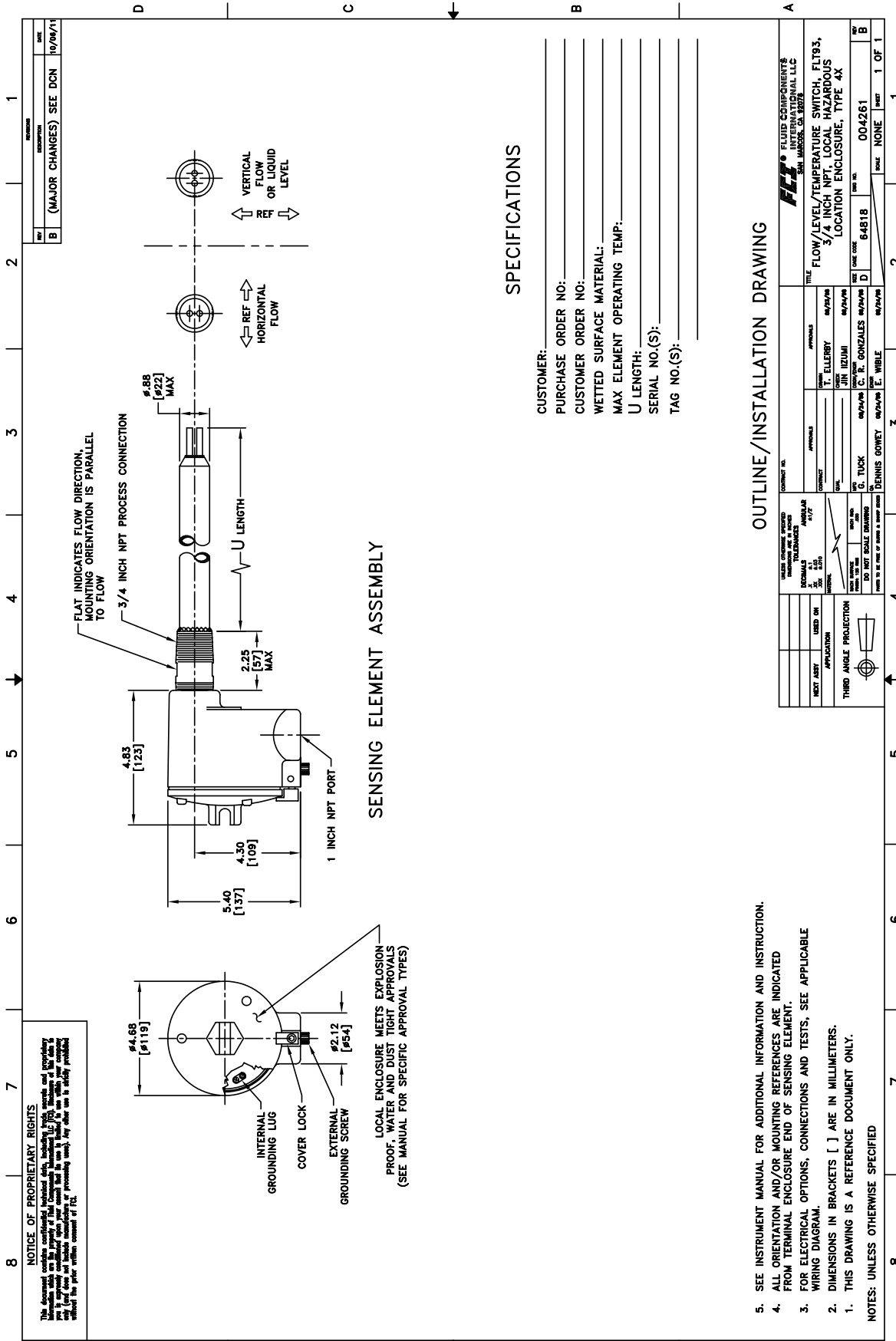

- 5. SEE INSTRUMENT MANUAL FOR ADDITIONAL INFORMATION AND INSTRUCTION.
 - 4. ALL ORIENTATION AND/OR MOUNTING REFERENCES ARE INDICATED FROM TERMINAL ENCLOSURE END OF SENSING ELEMENT.
 - 3. FOR ELECTRICAL OPTIONS, CONNECTIONS AND TESTS, SEE APPLICABLE WIRING DIAGRAM.
 - 2. DIMENSIONS IN BRACKETS [] ARE IN MILLIMETERS.
 - 1. THIS DRAWING IS A REFERENCE DOCUMENT ONLY.
- NOTES: UNLESS OTHERWISE SPECIFIED

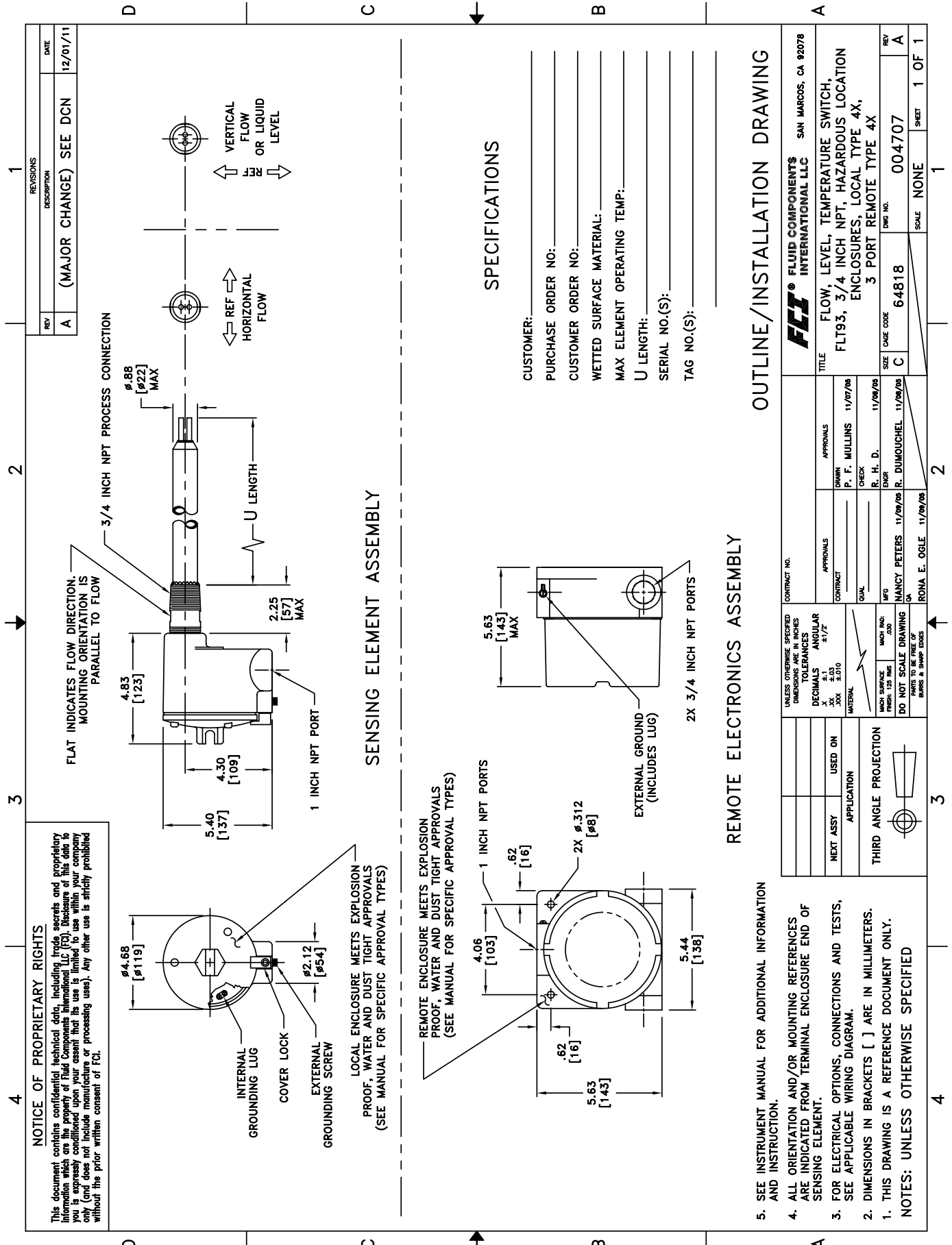

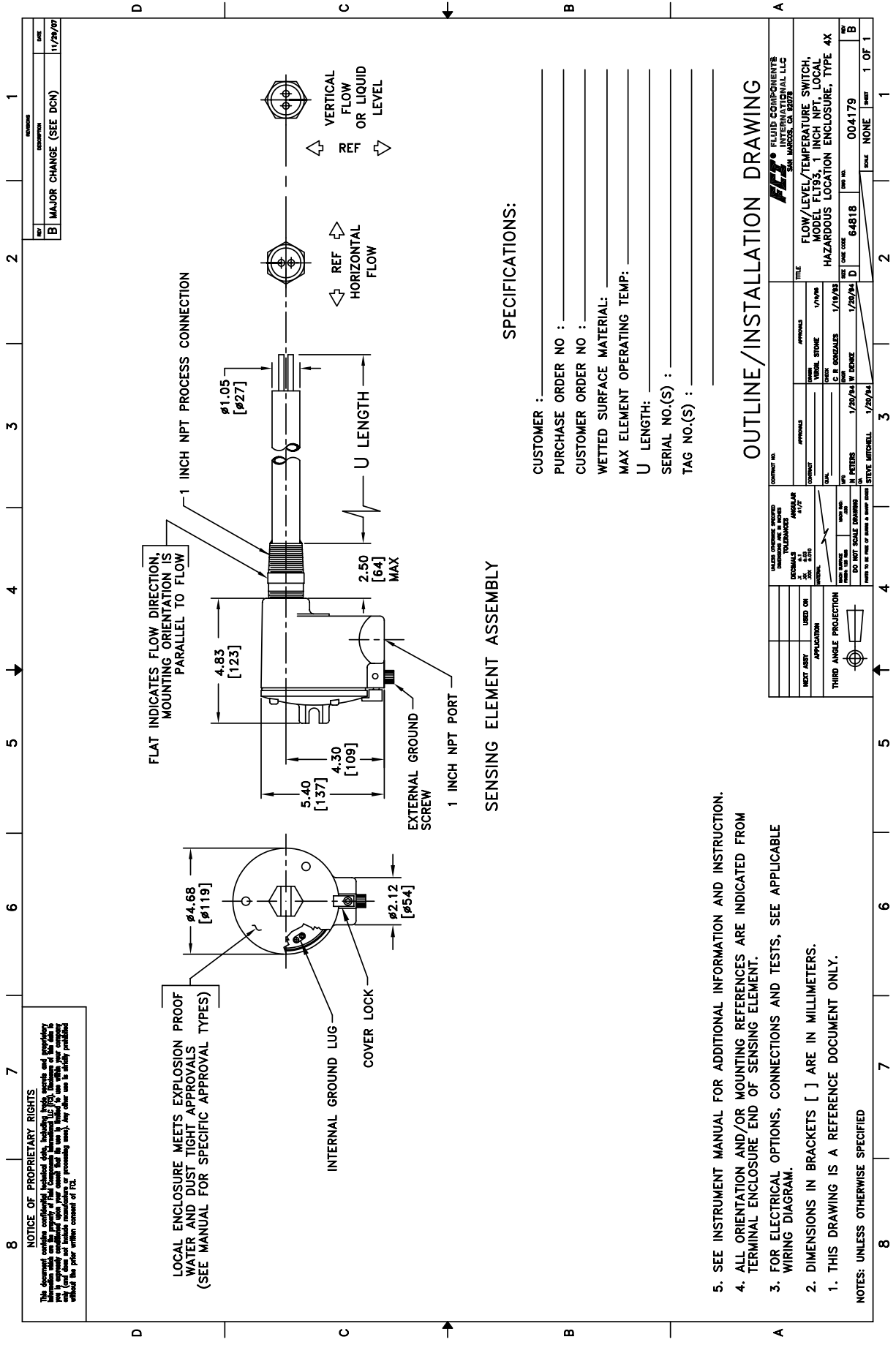

SPECIFICATIONS:

CUSTOMER : _____
 PURCHASE ORDER NO : _____
 CUSTOMER ORDER NO : _____
 WETTED SURFACE MATERIAL: _____
 MAX ELEMENT OPERATING TEMP: _____
 U LENGTH: _____
 SERIAL NO.(S) : _____
 TAG NO.(S) : _____

OUTLINE/INSTALLATION DRAWING

FCI FLUID COMPONENTS INTERNATIONAL LLC 5811 MARSHALL CA 95778	
TITLE FLOW/LEVEL/TEMPERATURE SWITCH, MODEL FLT93, 1 INCH NPT, LOCAL HAZARDOUS LOCATION ENCLOSURE, TYPE 4X	DATE 1/20/04
APPROVALS DESIGN: M. PETERS CHECKED: M. PETERS DATE: 1/20/04	APPROVALS DESIGN: M. PETERS CHECKED: M. PETERS DATE: 1/20/04
PART NO. 004179 REV. B	DRAWING NO. 64818 SHEET 1 OF 1

- SEE INSTRUMENT MANUAL FOR ADDITIONAL INFORMATION AND INSTRUCTION.
- ALL ORIENTATION AND/OR MOUNTING REFERENCES ARE INDICATED FROM TERMINAL ENCLOSURE END OF SENSING ELEMENT.
- FOR ELECTRICAL OPTIONS, CONNECTIONS AND TESTS, SEE APPLICABLE WIRING DIAGRAM.
- DIMENSIONS IN BRACKETS [] ARE IN MILLIMETERS.
- THIS DRAWING IS A REFERENCE DOCUMENT ONLY.

NOTES: UNLESS OTHERWISE SPECIFIED

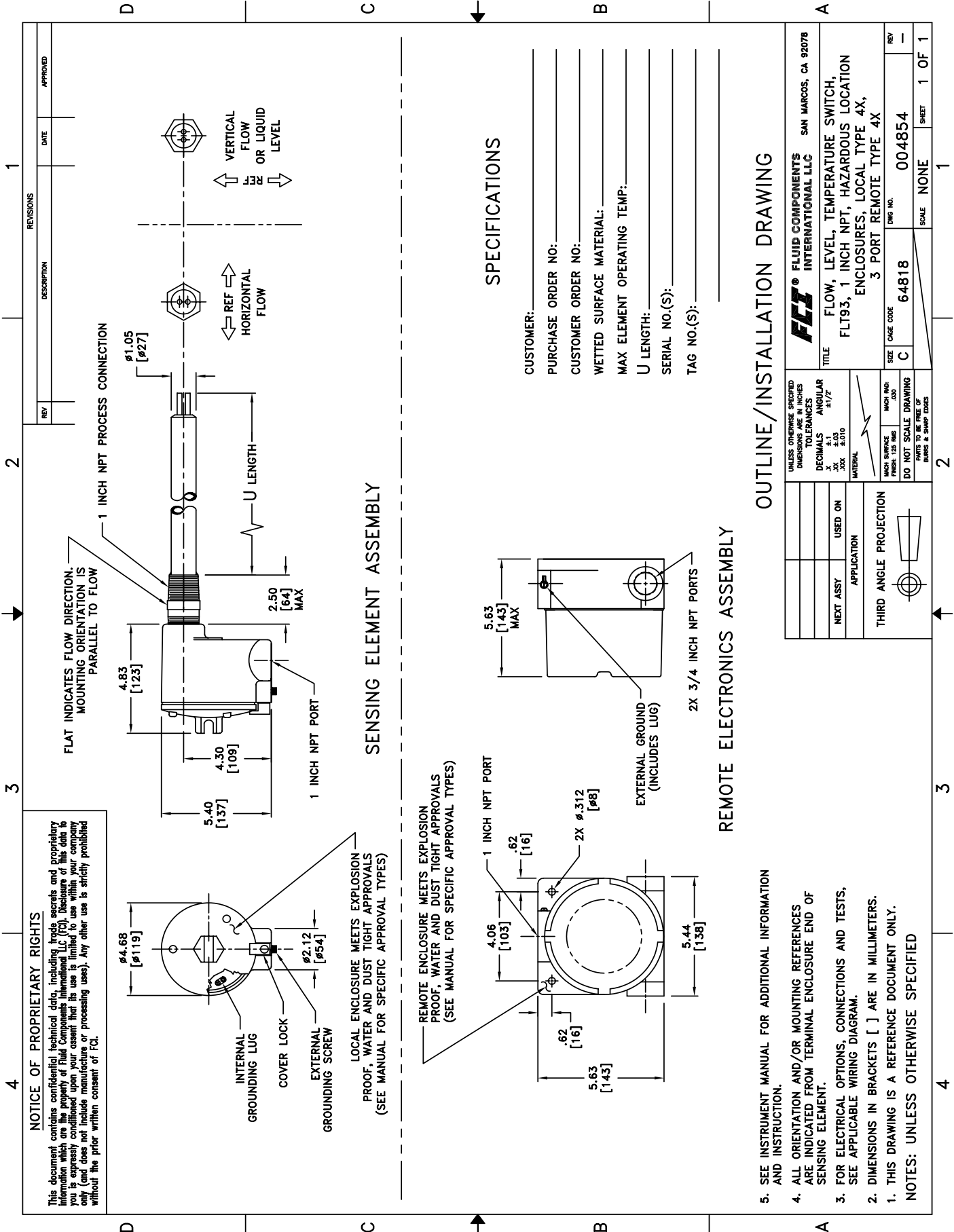

1" NPT with Local Hazardous Location Type 4X Enclosure : 3 Port Remote Type 4X

SPECIFICATIONS

CUSTOMER: _____

PURCHASE ORDER NO: _____

CUSTOMER ORDER NO: _____

WETTED SURFACE MATERIAL: _____

MAX ELEMENT OPERATING TEMP: _____

U LENGTH: _____

SERIAL NO.(S): _____

TAG NO.(S): _____

OUTLINE/INSTALLATION DRAWING

UNLESS OTHERWISE SPECIFIED DIMENSIONS ARE IN INCHES		TOLERANCES	
DECIMALS	ANGULAR		
X .1	±1/2°		
.XX	±.010		
MATERIAL			
MACH SURFACE FINISH: 1/25 RMS	MACH RAD: .000		
DO NOT SCALE DRAWING			
PARTS TO BE FREE OF BURRS & SHARP EDGES			
TITLE		SAN MARCOS, CA 92078	
FLOW, LEVEL, TEMPERATURE SWITCH, FLT93, 1 INCH NPT, HAZARDOUS LOCATION ENCLOSURES, LOCAL TYPE 4X, 3 PORT REMOTE TYPE 4X			
SIZE	CASE CODE	DWG NO.	REV
C	64818	004854	-
SCALE		SHEET	
NONE		1 OF 1	

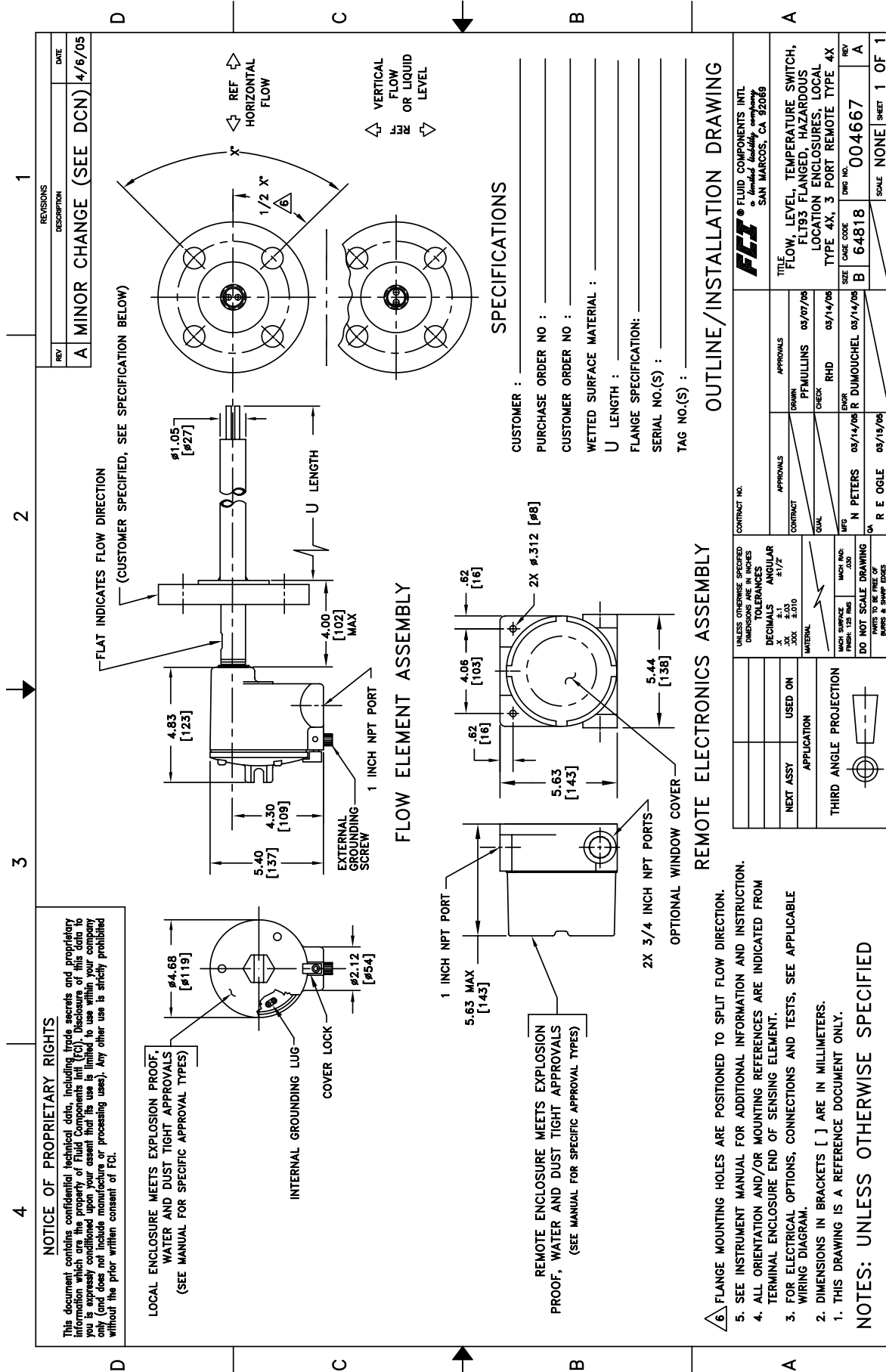

Flanged with Local Hazardous Location Type 4X Enclosure : 3 Port Remote Type 4X

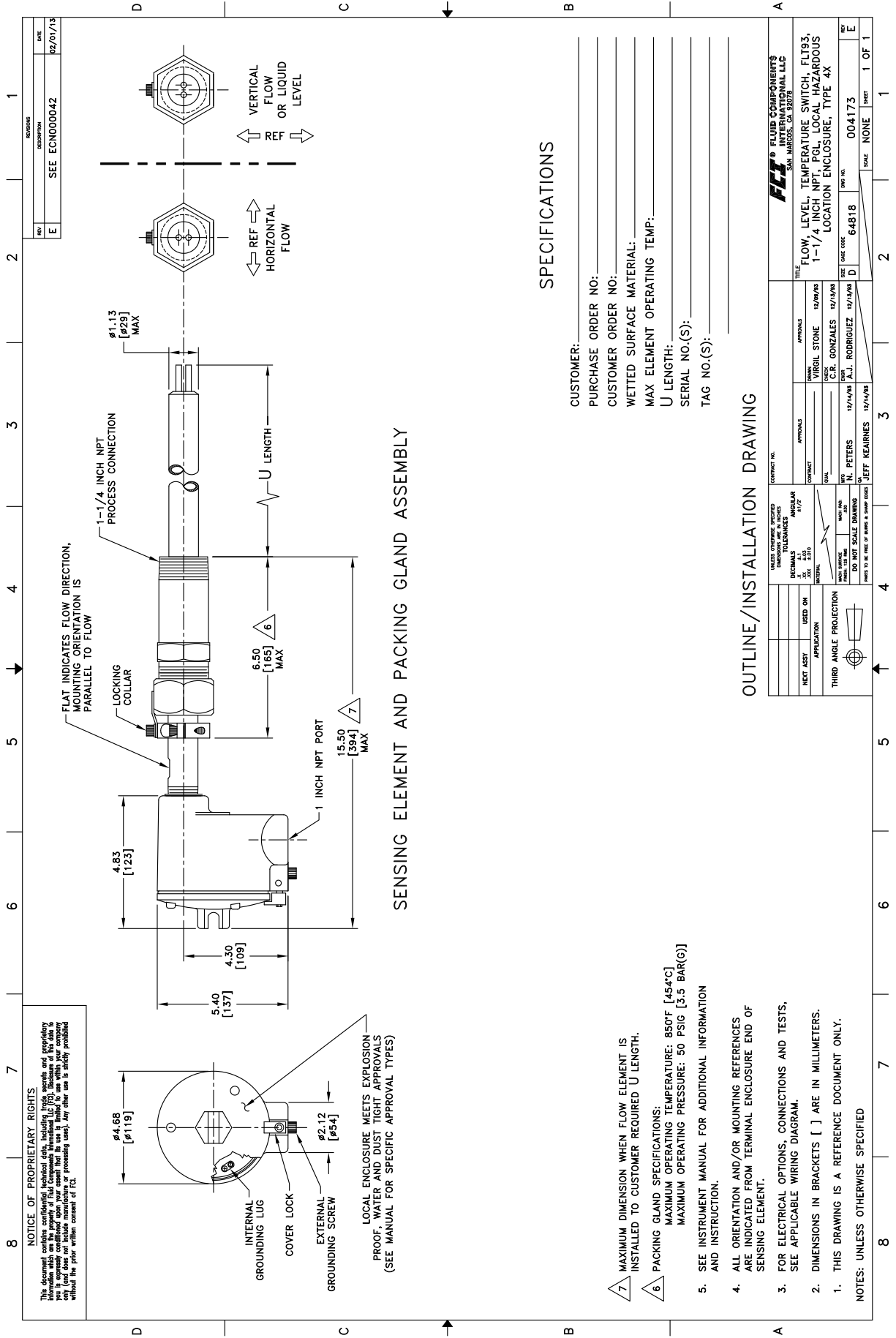

1-1/4" NPT Low Pressure Packing Gland with Local Hazardous Location Type 4X Enclosure

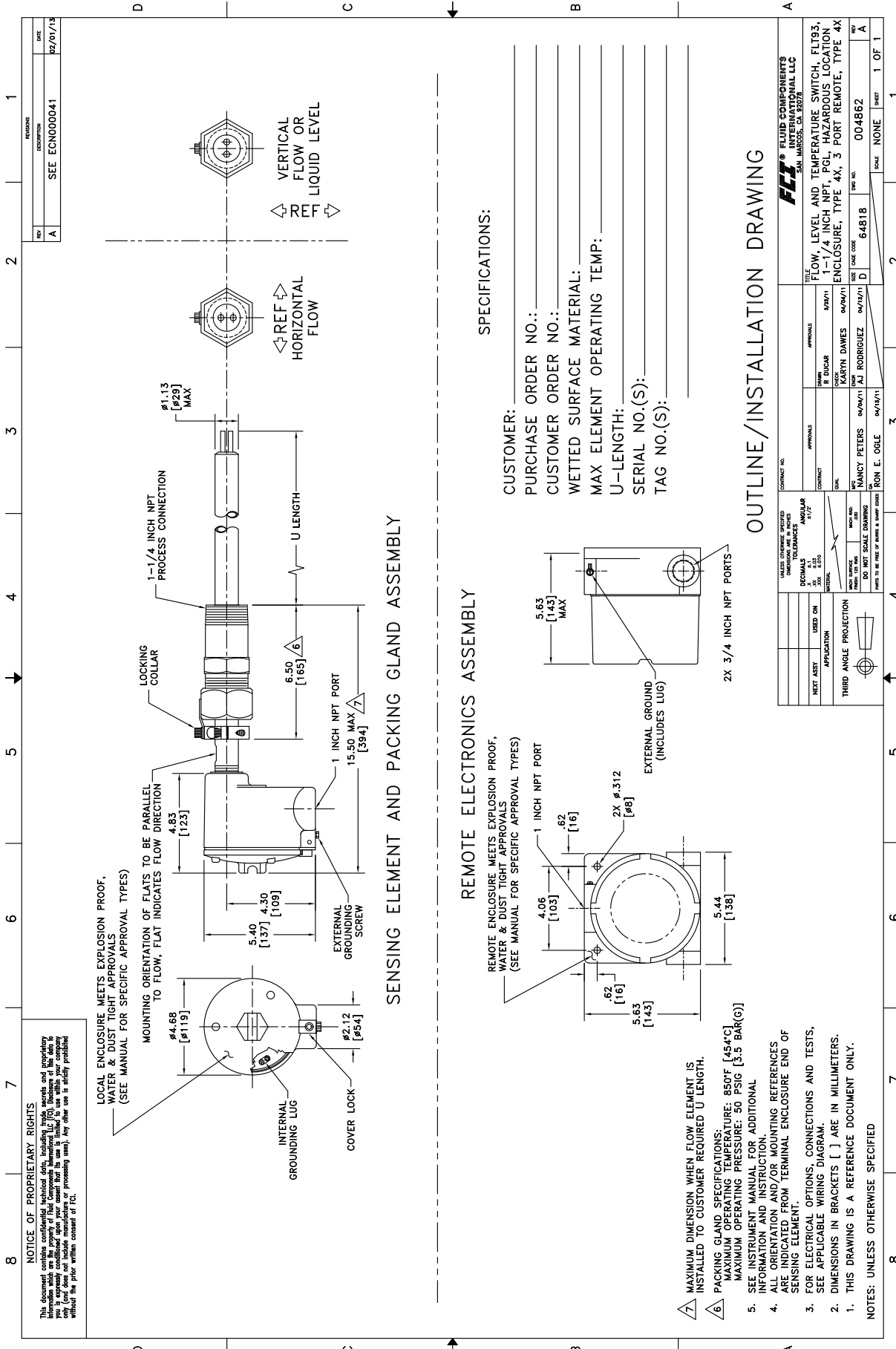

1-1/4" NPT Low Pressure Packing Gland with Local Hazardous Location Type 4X Enclosure : 3 Port Remote Type 4X

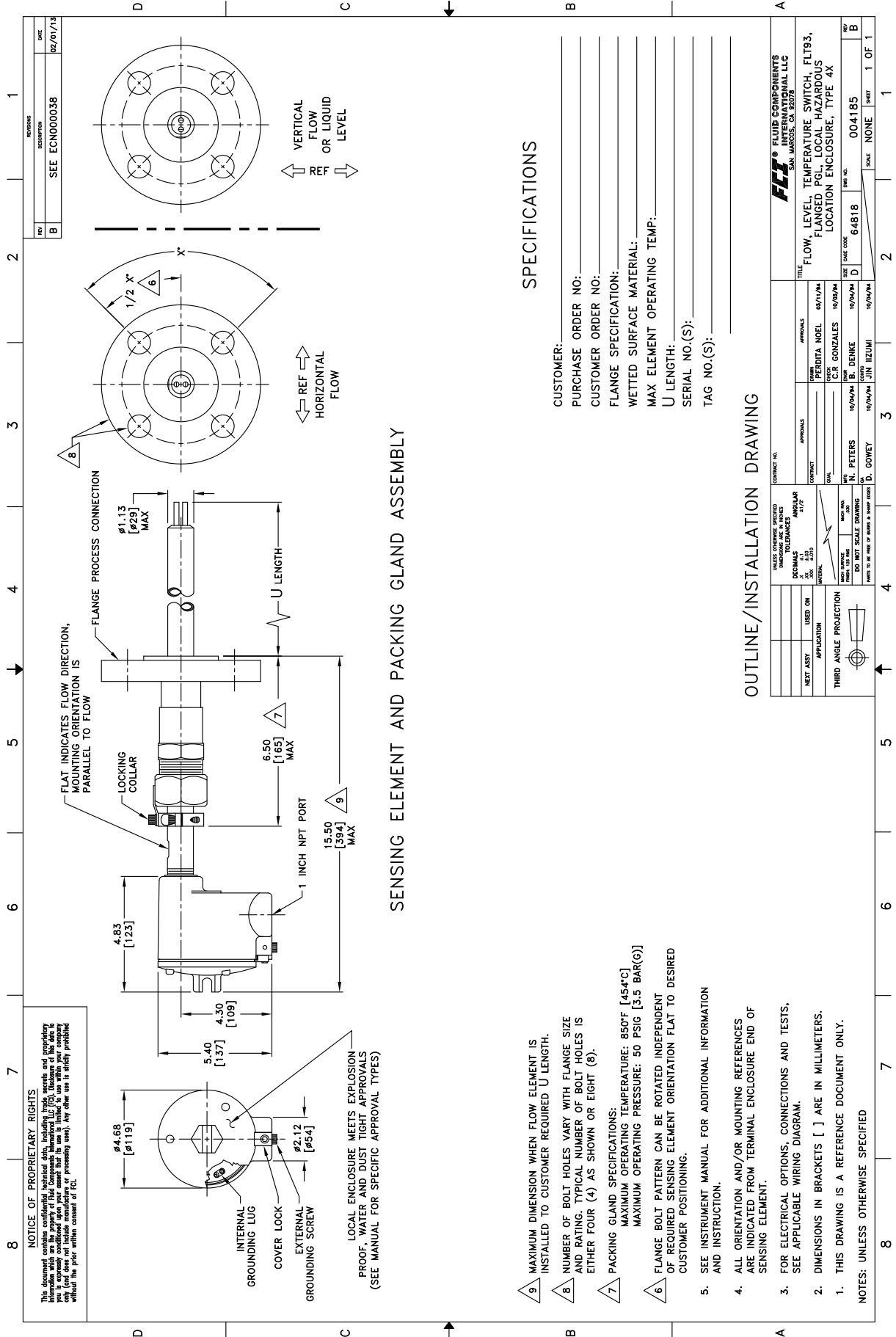

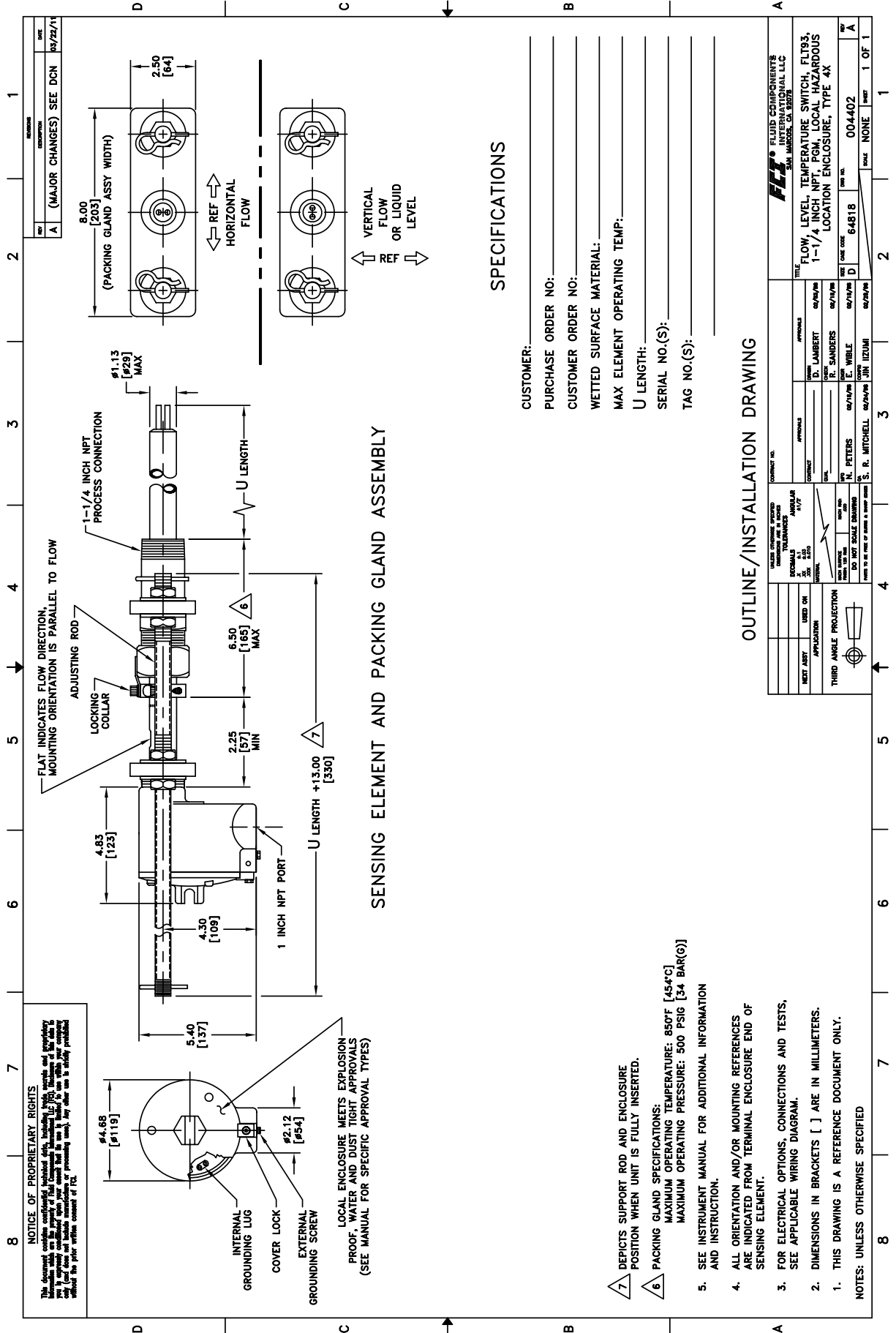

1-1/4" NPT, Medium Pressure Packing Gland with Local Hazardous Location Type 4X Enclosure

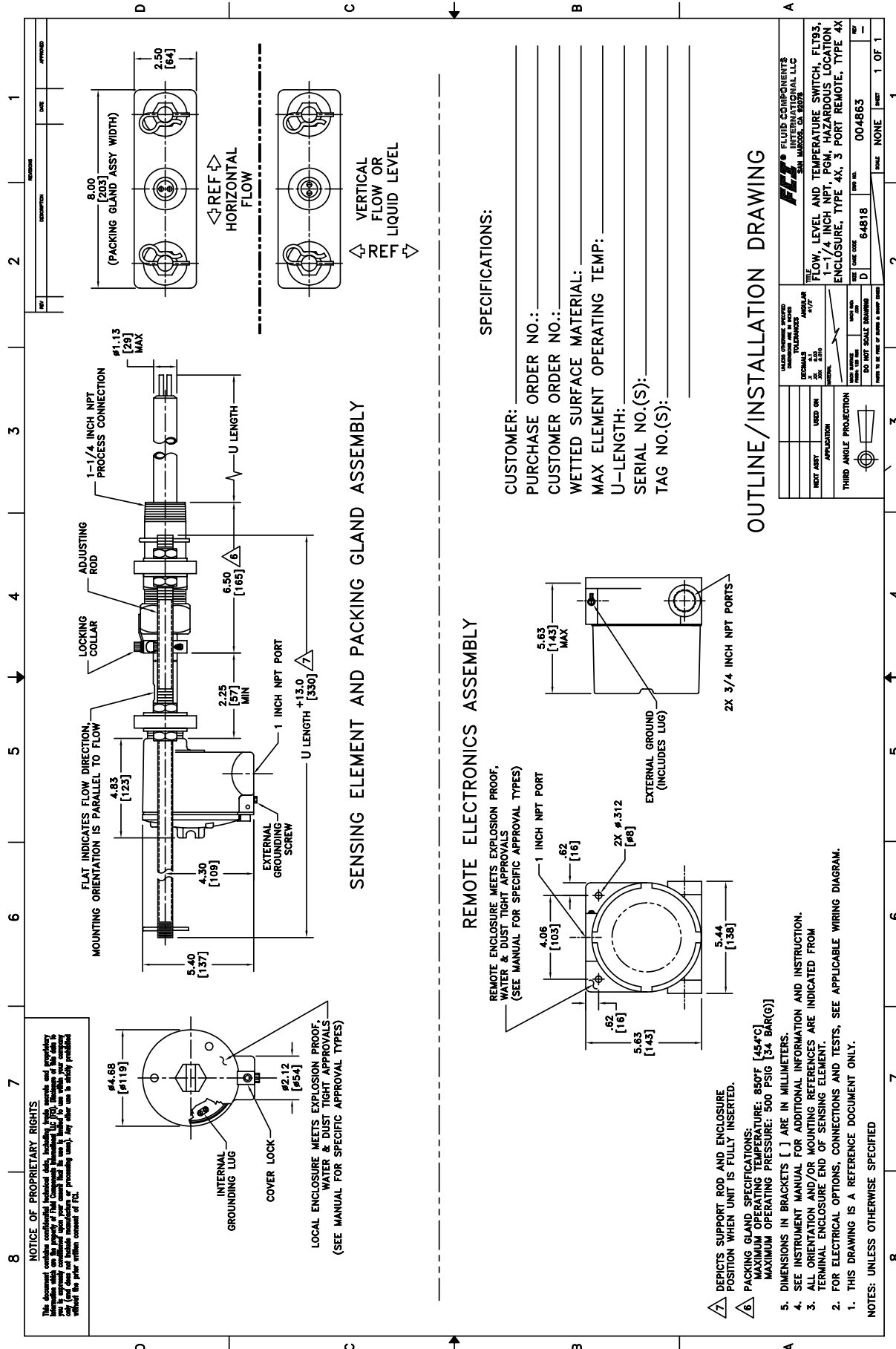

1-1/4" NPT, Medium Pressure Packing Gland with Local Hazardous Location Type 4X Enclosure : 3 Port Remote Type 4X

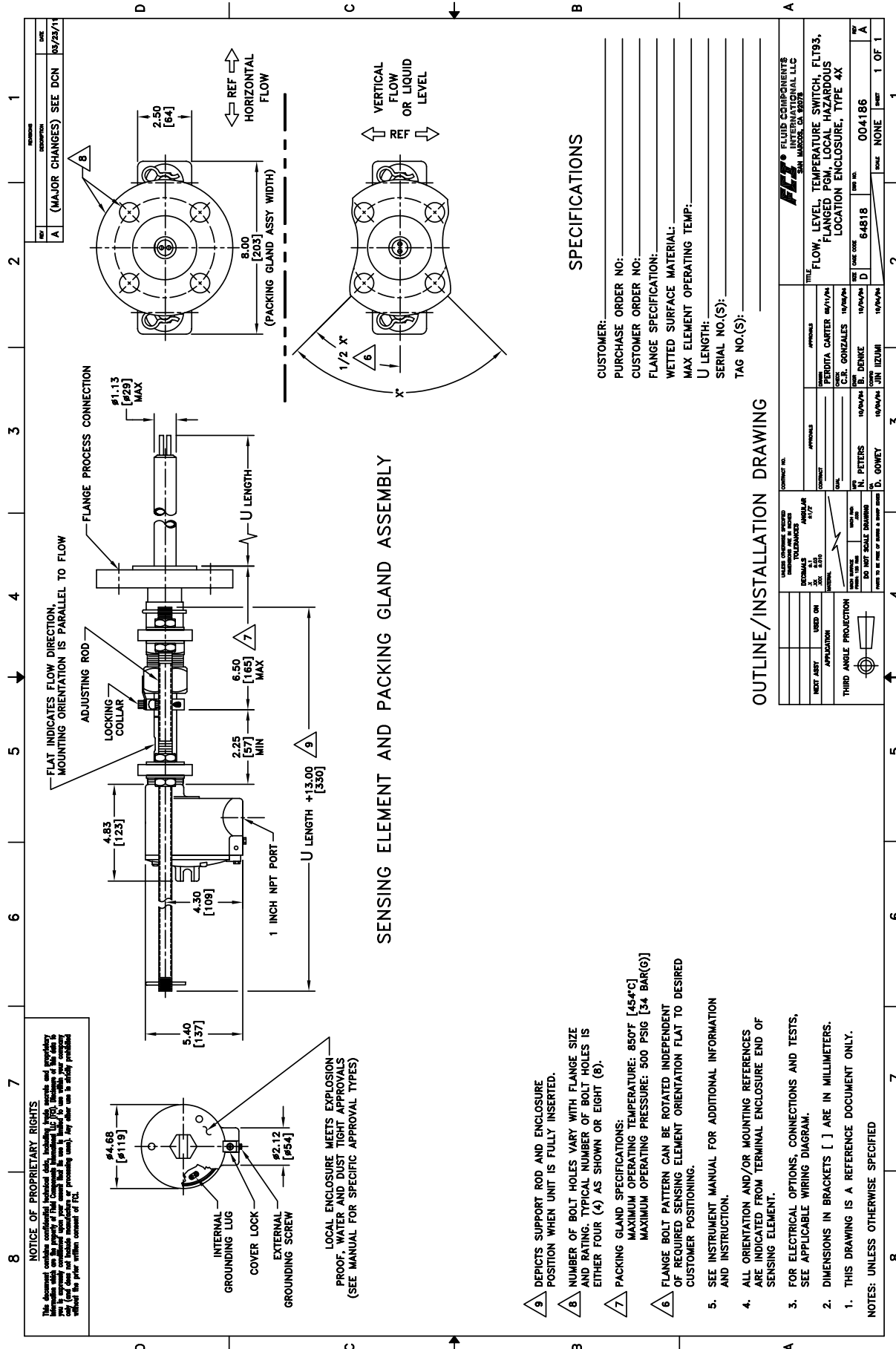

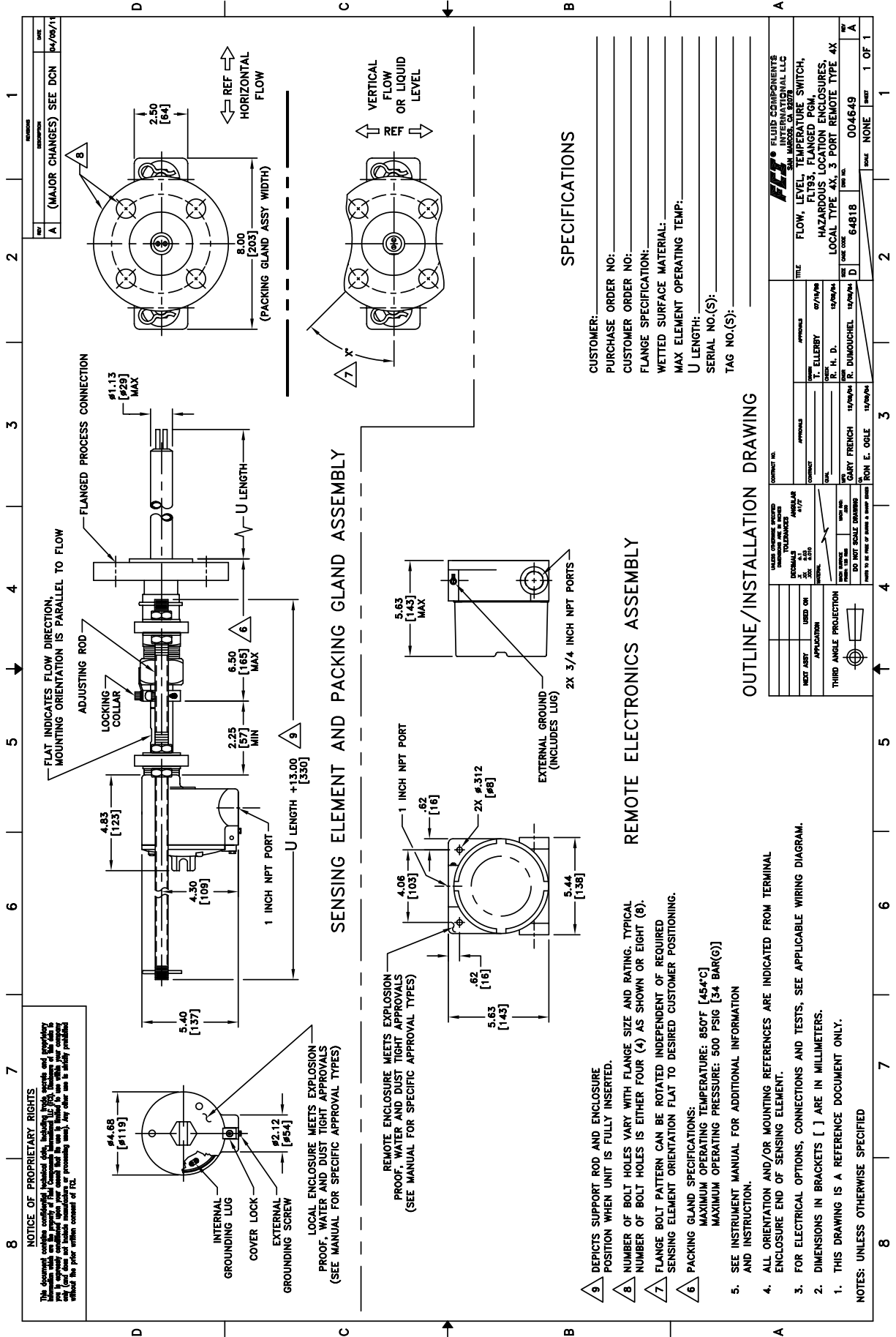

Flanged, Medium Pressure Packing Gland with Local Hazardous Location Type 4X Enclosure : 3 Port Remote Type 4X

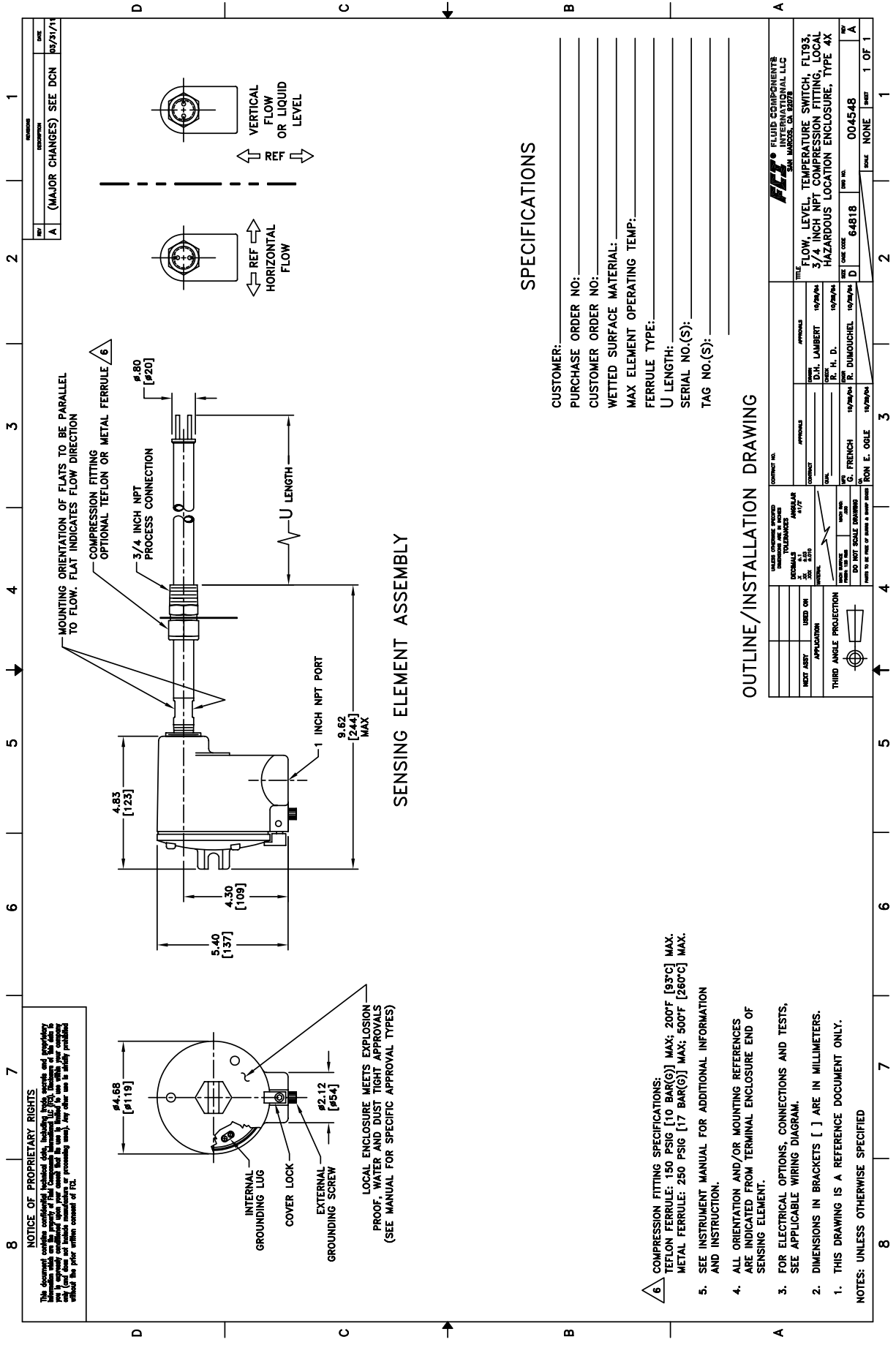

NOTICE OF PROPRIETARY RIGHTS
 This document contains confidential technical data, including design, methods, and processes, which are the property of Fluid Components International, LLC. It is intended for use only by the recipient and is not to be distributed, copied, or otherwise used without the prior written consent of FCI.

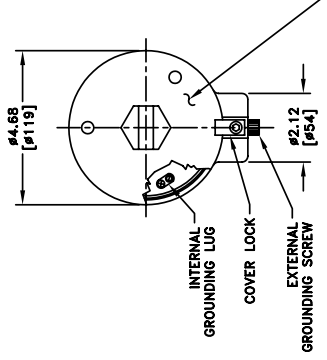

LOCAL ENCLOSURE MEETS EXPLOSION PROOF, WATER AND DUST TIGHT APPROVALS (SEE MANUAL FOR SPECIFIC APPROVAL TYPES)

SENSING ELEMENT ASSEMBLY

SPECIFICATIONS

CUSTOMER: _____
 PURCHASE ORDER NO: _____
 CUSTOMER ORDER NO: _____
 WETTED SURFACE MATERIAL: _____
 MAX ELEMENT OPERATING TEMP: _____
 FERRULE TYPE: _____
 U LENGTH: _____
 SERIAL NO.(S): _____
 TAG NO.(S): _____

- 6. COMPRESSION FITTING SPECIFICATIONS:
 TEFLON FERRULE: 150 PSIG [10 BAR(G)] MAX; 200°F [93°C] MAX.
 METAL FERRULE: 250 PSIG [17 BAR(G)] MAX; 500°F [260°C] MAX.
- 5. SEE INSTRUMENT MANUAL FOR ADDITIONAL INFORMATION AND INSTRUCTION.
- 4. ALL ORIENTATION AND/OR MOUNTING REFERENCES ARE INDICATED FROM TERMINAL ENCLOSURE END OF SENSING ELEMENT.
- 3. FOR ELECTRICAL OPTIONS, CONNECTIONS AND TESTS, SEE APPLICABLE WIRING DIAGRAM.
- 2. DIMENSIONS IN BRACKETS [] ARE IN MILLIMETERS.
- 1. THIS DRAWING IS A REFERENCE DOCUMENT ONLY.

OUTLINE/INSTALLATION DRAWING

MADE TO ORDER PARTS DIMENSIONS ARE IN INCHES DECIMALS FRACTIONS 1/16 1/8 1/4 3/8 1/2 5/8 3/4 7/8 1 1 1/4 1 1/2 1 3/4 2 2 1/4 2 1/2 3 3 1/4 3 1/2 4 4 1/4 4 1/2 5 5 1/4 5 1/2 6 6 1/4 6 1/2 7 7 1/4 7 1/2 8 8 1/4 8 1/2 9 9 1/4 9 1/2 10 10 1/4 10 1/2 11 11 1/4 11 1/2 12 12 1/4 12 1/2 13 13 1/4 13 1/2 14 14 1/4 14 1/2 15 15 1/4 15 1/2 16 16 1/4 16 1/2 17 17 1/4 17 1/2 18 18 1/4 18 1/2 19 19 1/4 19 1/2 20 20 1/4 20 1/2 21 21 1/4 21 1/2 22 22 1/4 22 1/2 23 23 1/4 23 1/2 24 24 1/4 24 1/2 25 25 1/4 25 1/2 26 26 1/4 26 1/2 27 27 1/4 27 1/2 28 28 1/4 28 1/2 29 29 1/4 29 1/2 30 30 1/4 30 1/2 31 31 1/4 31 1/2 32 32 1/4 32 1/2 33 33 1/4 33 1/2 34 34 1/4 34 1/2 35 35 1/4 35 1/2 36 36 1/4 36 1/2 37 37 1/4 37 1/2 38 38 1/4 38 1/2 39 39 1/4 39 1/2 40 40 1/4 40 1/2 41 41 1/4 41 1/2 42 42 1/4 42 1/2 43 43 1/4 43 1/2 44 44 1/4 44 1/2 45 45 1/4 45 1/2 46 46 1/4 46 1/2 47 47 1/4 47 1/2 48 48 1/4 48 1/2 49 49 1/4 49 1/2 50 50 1/4 50 1/2 51 51 1/4 51 1/2 52 52 1/4 52 1/2 53 53 1/4 53 1/2 54 54 1/4 54 1/2 55 55 1/4 55 1/2 56 56 1/4 56 1/2 57 57 1/4 57 1/2 58 58 1/4 58 1/2 59 59 1/4 59 1/2 60 60 1/4 60 1/2 61 61 1/4 61 1/2 62 62 1/4 62 1/2 63 63 1/4 63 1/2 64 64 1/4 64 1/2 65 65 1/4 65 1/2 66 66 1/4 66 1/2 67 67 1/4 67 1/2 68 68 1/4 68 1/2 69 69 1/4 69 1/2 70 70 1/4 70 1/2 71 71 1/4 71 1/2 72 72 1/4 72 1/2 73 73 1/4 73 1/2 74 74 1/4 74 1/2 75 75 1/4 75 1/2 76 76 1/4 76 1/2 77 77 1/4 77 1/2 78 78 1/4 78 1/2 79 79 1/4 79 1/2 80 80 1/4 80 1/2 81 81 1/4 81 1/2 82 82 1/4 82 1/2 83 83 1/4 83 1/2 84 84 1/4 84 1/2 85 85 1/4 85 1/2 86 86 1/4 86 1/2 87 87 1/4 87 1/2 88 88 1/4 88 1/2 89 89 1/4 89 1/2 90 90 1/4 90 1/2 91 91 1/4 91 1/2 92 92 1/4 92 1/2 93 93 1/4 93 1/2 94 94 1/4 94 1/2 95 95 1/4 95 1/2 96 96 1/4 96 1/2 97 97 1/4 97 1/2 98 98 1/4 98 1/2 99 99 1/4 99 1/2 100 100 1/4 100 1/2 101 101 1/4 101 1/2 102 102 1/4 102 1/2 103 103 1/4 103 1/2 104 104 1/4 104 1/2 105 105 1/4 105 1/2 106 106 1/4 106 1/2 107 107 1/4 107 1/2 108 108 1/4 108 1/2 109 109 1/4 109 1/2 110 110 1/4 110 1/2 111 111 1/4 111 1/2 112 112 1/4 112 1/2 113 113 1/4 113 1/2 114 114 1/4 114 1/2 115 115 1/4 115 1/2 116 116 1/4 116 1/2 117 117 1/4 117 1/2 118 118 1/4 118 1/2 119 119 1/4 119 1/2 120 120 1/4 120 1/2 121 121 1/4 121 1/2 122 122 1/4 122 1/2 123 123 1/4 123 1/2 124 124 1/4 124 1/2 125 125 1/4 125 1/2 126 126 1/4 126 1/2 127 127 1/4 127 1/2 128 128 1/4 128 1/2 129 129 1/4 129 1/2 130 130 1/4 130 1/2 131 131 1/4 131 1/2 132 132 1/4 132 1/2 133 133 1/4 133 1/2 134 134 1/4 134 1/2 135 135 1/4 135 1/2 136 136 1/4 136 1/2 137 137 1/4 137 1/2 138 138 1/4 138 1/2 139 139 1/4 139 1/2 140 140 1/4 140 1/2 141 141 1/4 141 1/2 142 142 1/4 142 1/2 143 143 1/4 143 1/2 144 144 1/4 144 1/2 145 145 1/4 145 1/2 146 146 1/4 146 1/2 147 147 1/4 147 1/2 148 148 1/4 148 1/2 149 149 1/4 149 1/2 150 150 1/4 150 1/2 151 151 1/4 151 1/2 152 152 1/4 152 1/2 153 153 1/4 153 1/2 154 154 1/4 154 1/2 155 155 1/4 155 1/2 156 156 1/4 156 1/2 157 157 1/4 157 1/2 158 158 1/4 158 1/2 159 159 1/4 159 1/2 160 160 1/4 160 1/2 161 161 1/4 161 1/2 162 162 1/4 162 1/2 163 163 1/4 163 1/2 164 164 1/4 164 1/2 165 165 1/4 165 1/2 166 166 1/4 166 1/2 167 167 1/4 167 1/2 168 168 1/4 168 1/2 169 169 1/4 169 1/2 170 170 1/4 170 1/2 171 171 1/4 171 1/2 172 172 1/4 172 1/2 173 173 1/4 173 1/2 174 174 1/4 174 1/2 175 175 1/4 175 1/2 176 176 1/4 176 1/2 177 177 1/4 177 1/2 178 178 1/4 178 1/2 179 179 1/4 179 1/2 180 180 1/4 180 1/2 181 181 1/4 181 1/2 182 182 1/4 182 1/2 183 183 1/4 183 1/2 184 184 1/4 184 1/2 185 185 1/4 185 1/2 186 186 1/4 186 1/2 187 187 1/4 187 1/2 188 188 1/4 188 1/2 189 189 1/4 189 1/2 190 190 1/4 190 1/2 191 191 1/4 191 1/2 192 192 1/4 192 1/2 193 193 1/4 193 1/2 194 194 1/4 194 1/2 195 195 1/4 195 1/2 196 196 1/4 196 1/2 197 197 1/4 197 1/2 198 198 1/4 198 1/2 199 199 1/4 199 1/2 200 200 1/4 200 1/2 201 201 1/4 201 1/2 202 202 1/4 202 1/2 203 203 1/4 203 1/2 204 204 1/4 204 1/2 205 205 1/4 205 1/2 206 206 1/4 206 1/2 207 207 1/4 207 1/2 208 208 1/4 208 1/2 209 209 1/4 209 1/2 210 210 1/4 210 1/2 211 211 1/4 211 1/2 212 212 1/4 212 1/2 213 213 1/4 213 1/2 214 214 1/4 214 1/2 215 215 1/4 215 1/2 216 216 1/4 216 1/2 217 217 1/4 217 1/2 218 218 1/4 218 1/2 219 219 1/4 219 1/2 220 220 1/4 220 1/2 221 221 1/4 221 1/2 222 222 1/4 222 1/2 223 223 1/4 223 1/2 224 224 1/4 224 1/2 225 225 1/4 225 1/2 226 226 1/4 226 1/2 227 227 1/4 227 1/2 228 228 1/4 228 1/2 229 229 1/4 229 1/2 230 230 1/4 230 1/2 231 231 1/4 231 1/2 232 232 1/4 232 1/2 233 233 1/4 233 1/2 234 234 1/4 234 1/2 235 235 1/4 235 1/2 236 236 1/4 236 1/2 237 237 1/4 237 1/2 238 238 1/4 238 1/2 239 239 1/4 239 1/2 240 240 1/4 240 1/2 241 241 1/4 241 1/2 242 242 1/4 242 1/2 243 243 1/4 243 1/2 244 244 1/4 244 1/2 245 245 1/4 245 1/2 246 246 1/4 246 1/2 247 247 1/4 247 1/2 248 248 1/4 248 1/2 249 249 1/4 249 1/2 250 250 1/4 250 1/2 251 251 1/4 251 1/2 252 252 1/4 252 1/2 253 253 1/4 253 1/2 254 254 1/4 254 1/2 255 255 1/4 255 1/2 256 256 1/4 256 1/2 257 257 1/4 257 1/2 258 258 1/4 258 1/2 259 259 1/4 259 1/2 260 260 1/4 260 1/2 261 261 1/4 261 1/2 262 262 1/4 262 1/2 263 263 1/4 263 1/2 264 264 1/4 264 1/2 265 265 1/4 265 1/2 266 266 1/4 266 1/2 267 267 1/4 267 1/2 268 268 1/4 268 1/2 269 269 1/4 269 1/2 270 270 1/4 270 1/2 271 271 1/4 271 1/2 272 272 1/4 272 1/2 273 273 1/4 273 1/2 274 274 1/4 274 1/2 275 275 1/4 275 1/2 276 276 1/4 276 1/2 277 277 1/4 277 1/2 278 278 1/4 278 1/2 279 279 1/4 279 1/2 280 280 1/4 280 1/2 281 281 1/4 281 1/2 282 282 1/4 282 1/2 283 283 1/4 283 1/2 284 284 1/4 284 1/2 285 285 1/4 285 1/2 286 286 1/4 286 1/2 287 287 1/4 287 1/2 288 288 1/4 288 1/2 289 289 1/4 289 1/2 290 290 1/4 290 1/2 291 291 1/4 291 1/2 292 292 1/4 292 1/2 293 293 1/4 293 1/2 294 294 1/4 294 1/2 295 295 1/4 295 1/2 296 296 1/4 296 1/2 297 297 1/4 297 1/2 298 298 1/4 298 1/2 299 299 1/4 299 1/2 300 300 1/4 300 1/2 301 301 1/4 301 1/2 302 302 1/4 302 1/2 303 303 1/4 303 1/2 304 304 1/4 304 1/2 305 305 1/4 305 1/2 306 306 1/4 306 1/2 307 307 1/4 307 1/2 308 308 1/4 308 1/2 309 309 1/4 309 1/2 310 310 1/4 310 1/2 311 311 1/4 311 1/2 312 312 1/4 312 1/2 313 313 1/4 313 1/2 314 314 1/4 314 1/2 315 315 1/4 315 1/2 316 316 1/4 316 1/2 317 317 1/4 317 1/2 318 318 1/4 318 1/2 319 319 1/4 319 1/2 320 320 1/4 320 1/2 321 321 1/4 321 1/2 322 322 1/4 322 1/2 323 323 1/4 323 1/2 324 324 1/4 324 1/2 325 325 1/4 325 1/2 326 326 1/4 326 1/2 327 327 1/4 327 1/2 328 328 1/4 328 1/2 329 329 1/4 329 1/2 330 330 1/4 330 1/2 331 331 1/4 331 1/2 332 332 1/4 332 1/2 333 333 1/4 333 1/2 334 334 1/4 334 1/2 335 335 1/4 335 1/2 336 336 1/4 336 1/2 337 337 1/4 337 1/2 338 338 1/4 338 1/2 339 339 1/4 339 1/2 340 340 1/4 340 1/2 341 341 1/4 341 1/2 342 342 1/4 342 1/2 343 343 1/4 343 1/2 344 344 1/4 344 1/2 345 345 1/4 345 1/2 346 346 1/4 346 1/2 347 347 1/4 347 1/2 348 348 1/4 348 1/2 349 349 1/4 349 1/2 350 350 1/4 350 1/2 351 351 1/4 351 1/2 352 352 1/4 352 1/2 353 353 1/4 353 1/2 354 354 1/4 354 1/2 355 355 1/4 355 1/2 356 356 1/4 356 1/2 357 357 1/4 357 1/2 358 358 1/4 358 1/2 359 359 1/4 359 1/2 360 360 1/4 360 1/2 361 361 1/4 361 1/2 362 362 1/4 362 1/2 363 363 1/4 363 1/2 364 364 1/4 364 1/2 365 365 1/4 365 1/2 366 366 1/4 366 1/2 367 367 1/4 367 1/2 368 368 1/4 368 1/2 369 369 1/4 369 1/2 370 370 1/4 370 1/2 371 371 1/4 371 1/2 372 372 1/4 372 1/2 373 373 1/4 373 1/2 374 374 1/4 374 1/2 375 375 1/4 375 1/2 376 376 1/4 376 1/2 377 377 1/4 377 1/2 378 378 1/4 378 1/2 379 379 1/4 379 1/2 380 380 1/4 380 1/2 381 381 1/4 381 1/2 382 382 1/4 382 1/2 383 383 1/4 383 1/2 384 384 1/4 384 1/2 385 385 1/4 385 1/2 386 386 1/4 386 1/2 387 387 1/4 387 1/2 388 388 1/4 388 1/2 389 389 1/4 389 1/2 390 390 1/4 390 1/2 391 391 1/4 391 1/2 392 392 1/4 392 1/2 393 393 1/4 393 1/2 394 394 1/4 394 1/2 395 395 1/4 395 1/2 396 396 1/4 396 1/2 397 397 1/4 397 1/2 398 398 1/4 398 1/2 399 399 1/4 399 1/2 400 400 1/4 400 1/2 401 401 1/4 401 1/2 402 402 1/4 402 1/2 403 403 1/4 403 1/2 404 404 1/4 404 1/2 405 405 1/4 405 1/2 406 406 1/4 406 1/2 407 407 1/4 407 1/2 408 408 1/4 408 1/2 409 409 1/4 409 1/2 410 410 1/4 410 1/2 411 411 1/4 411 1/2 412 412 1/4 412 1/2 413 413 1/4 413 1/2 414 414 1/4 414 1/2 415 415 1/4 415 1/2 416 416 1/4 416 1/2 417 417 1/4 417 1/2 418 418 1/4 418 1/2 419 419 1/4 419 1/2 420 420 1/4 420 1/2 421 421 1/4 421 1/2 422 422 1/4 422 1/2 423 423 1/4 423 1/2 424 424 1/4 424 1/2 425 425 1/4 425 1/2 426 426 1/4 426 1/2 427 427 1/4 427 1/2 428 428 1/4 428 1/2 429 429 1/4 429 1/2 430 430 1/4 430 1/2 431 431 1/4 431 1/2 432 432 1/4 432 1/2 433 433 1/4 433 1/2 434 434 1/4 434 1/2 435 435 1/4 435 1/2 436 436 1/4 436 1/2 437 437 1/4 437 1/2 438 438 1/4 438 1/2 439 439 1/4 439 1/2 440 440 1/4 440 1/2 441 441 1/4 441 1/2 442 442 1/4 442 1/2 443 443 1/4 443 1/2 444 444 1/4 444 1/2 445 445 1/4 445 1/2 446 446 1/4 446 1/2 447 447 1/4 447 1/2 448 448 1/4 448 1/2 449 449 1/4 449 1/2 450 450 1/4 450 1/2 451 451 1/4 451 1/2 452 452 1/4 452 1/2 453 453 1/4 453 1/2 454 454 1/4 454 1/2 455 455 1/4 455 1/2 456 456 1/4 456 1/2 457 457 1/4 457 1/2 458 458 1/4 458 1/2 459 459 1/4 459 1/2 460 460 1/4 460 1/2 461 461 1/4 461 1/2 462 462 1/4 462 1/2 463 463 1/4 463 1/2 464 464 1/4 464 1/2 465 465 1/4 465 1/2 466 466 1/4 466 1/2 467 467 1/4 467 1/2 468 468 1/4 468 1/2 469 469 1/4 469 1/2 470 470 1/4 470 1/2 471 471 1/4 471 1/2 472 472 1/4 472 1/2 473 473 1/4 473 1/2 474 474 1/4 474 1/2 475 475 1/4 475 1/2 476 476 1/4 476 1/2 477 477 1/4 477 1/2 478 478 1/4 478 1/2 479 479 1/4 479 1/2 480 480 1/4 480 1/2 481 481 1/4 481 1/2 482 482 1/4 482 1/2 483 483 1/4 483 1/2 484 484 1/4 484 1/2 485 485 1/4 485 1/2 486 486 1/4 486 1/2 487 487 1/4 487 1/2 488 488 1/4 488 1/2 489 489 1/4 489 1/2 490 490 1/4 490 1/2 491 491 1/4 491 1/2 492 492 1/4 492 1/2 493 493 1/4 493 1/2 494 494 1/4 494 1/2 495 495 1/4 495 1/2 496 496 1/4 496 1/2 497 497 1/4 497 1/2 498 498 1/4 498 1/2 499 499 1/4 499 1/2 500 500 1/4 500 1/2 501 501 1/4 501 1/2 502 502 1/4 502 1/2 503 503 1/4 503 1/2 504 504 1/4 504 1/2 505 505 1/4 505 1/2 506 506 1/4 506 1/2 507 507 1/4 507 1/2 508 508 1/4 508 1/2 509 509 1/4 509 1/2 510 510 1/4 510 1/2 511 511 1/4 511 1/2 512 512 1/4 512 1/2 513 513 1/4 513 1/2 514 514 1/4 514 1/2 515 515 1/4 515 1/2 516 516 1/4 516 1/2 517 517 1/4 517 1/2 518 518 1/4 518 1/2 519 519 1/4 519 1/2 520 520 1/4 520 1/2 521 521 1/4 521 1/2 522 522 1/4 522 1/2 523 523 1/4 523 1/2 524 524 1/4 524 1/2 525 525 1/4 525 1/2 526 526 1/4 526 1/2 527 527 1/4 527 1/2 528 528 1/4 528 1/2 529 529 1/4 529 1/2 530 530 1/4 530 1/2 531 531 1/4 531 1/2 532 532 1/4 532 1/2 533 533 1/4 533 1/2 534 534 1/4 534 1/2 535 535 1/4 535 1/2 536 536 1/4 536 1/2 537 537 1/4 537 1/2 538 538 1/4 538 1/2 539 539 1/4 539 1/2 540 540 1/4 540 1/2 541 541 1/4 541 1/2 542 542 1/4 542 1/2 543 543 1/4 543 1/2 544 544 1/4 544 1/2 545 545 1/4 545 1/2 546 546 1/4 546 1/2 547 547 1/4 547 1/2 548 548 1/4 548 1/2 549 549 1/4 549 1/2 550 550 1/4 550 1/2 551 551 1/4 551 1/2 552 552 1/4 552 1/2 553 553 1/4 553 1/2 554 554 1/4 554 1/2 555 555 1/4 555 1/2 556 556 1/4 556 1/2 557 557 1/4 557 1/2 558 558 1/4 558 1/2 559 559 1/4 559 1/2 560 560 1/4 560 1/2 561 561 1/4 561 1/2 562 562 1/4 562 1/2 563 563 1/4 563 1/2 564 564 1/4 564 1/2 565 565 1/4 565 1/2 566 566 1/4 566 1/2 567 567 1/4 567 1/2 568 568 1/4 568 1/2 569 569 1/4 569 1/2 570 570 1/4 570 1/2 571 571 1/4 571 1/2 572 572 1/4 572 1/2 573 573 1/4 573 1/2 574 574 1/4 574 1/2 575 575 1/4 575 1/2 576 576 1/4 576 1/2 577 577 1/4	
---	--

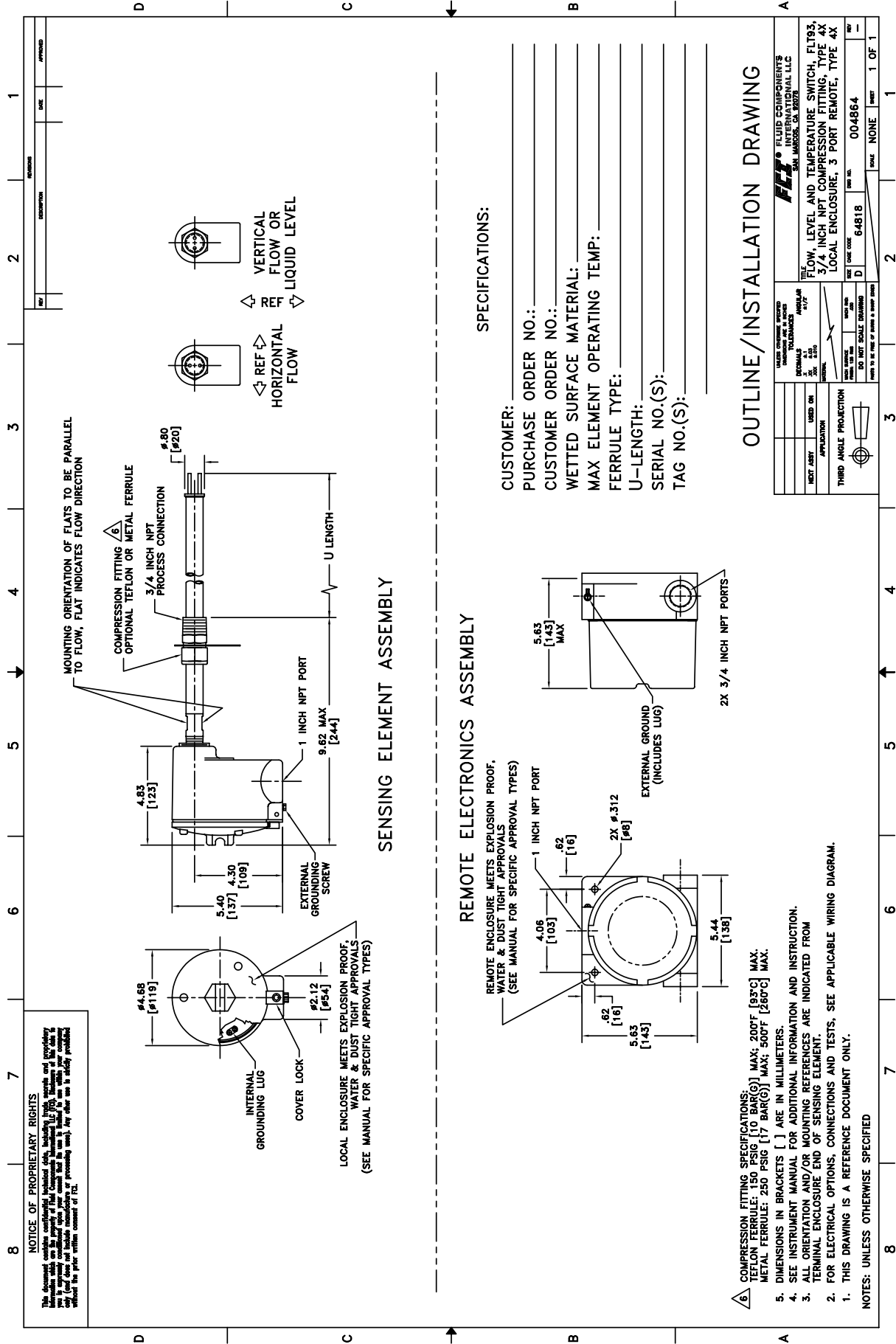

3/4" MNPT Compression Fitting with Local Hazardous Location Type 4X Enclosure : 3 Port Remote Type 4X

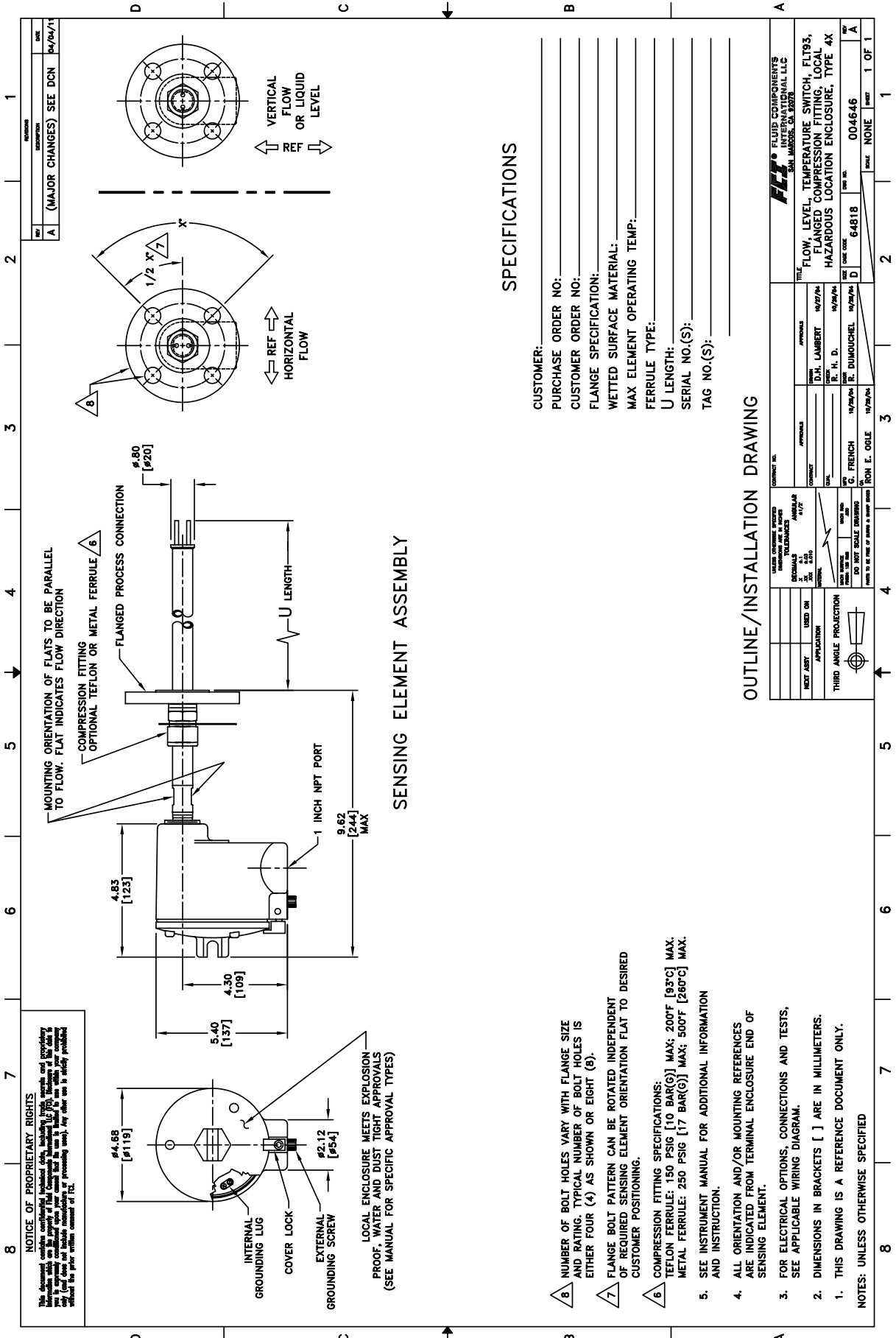

Flanged Compression Fitting with Local Hazardous Location Type 4X Enclosure

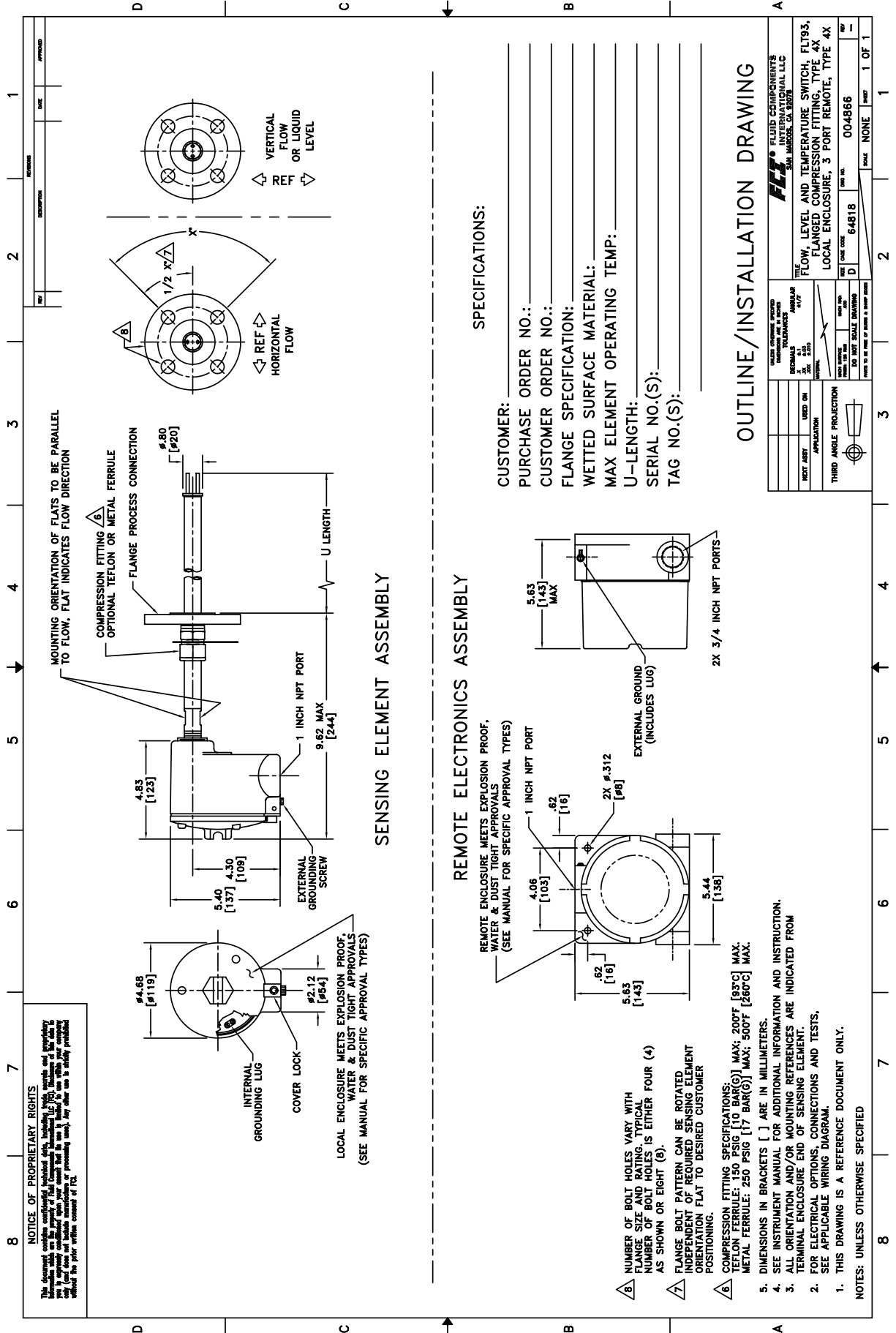

Flanged Compression Fitting with Local Hazardous Location Type 4X Enclosure : 3 Port Remote Type 4X

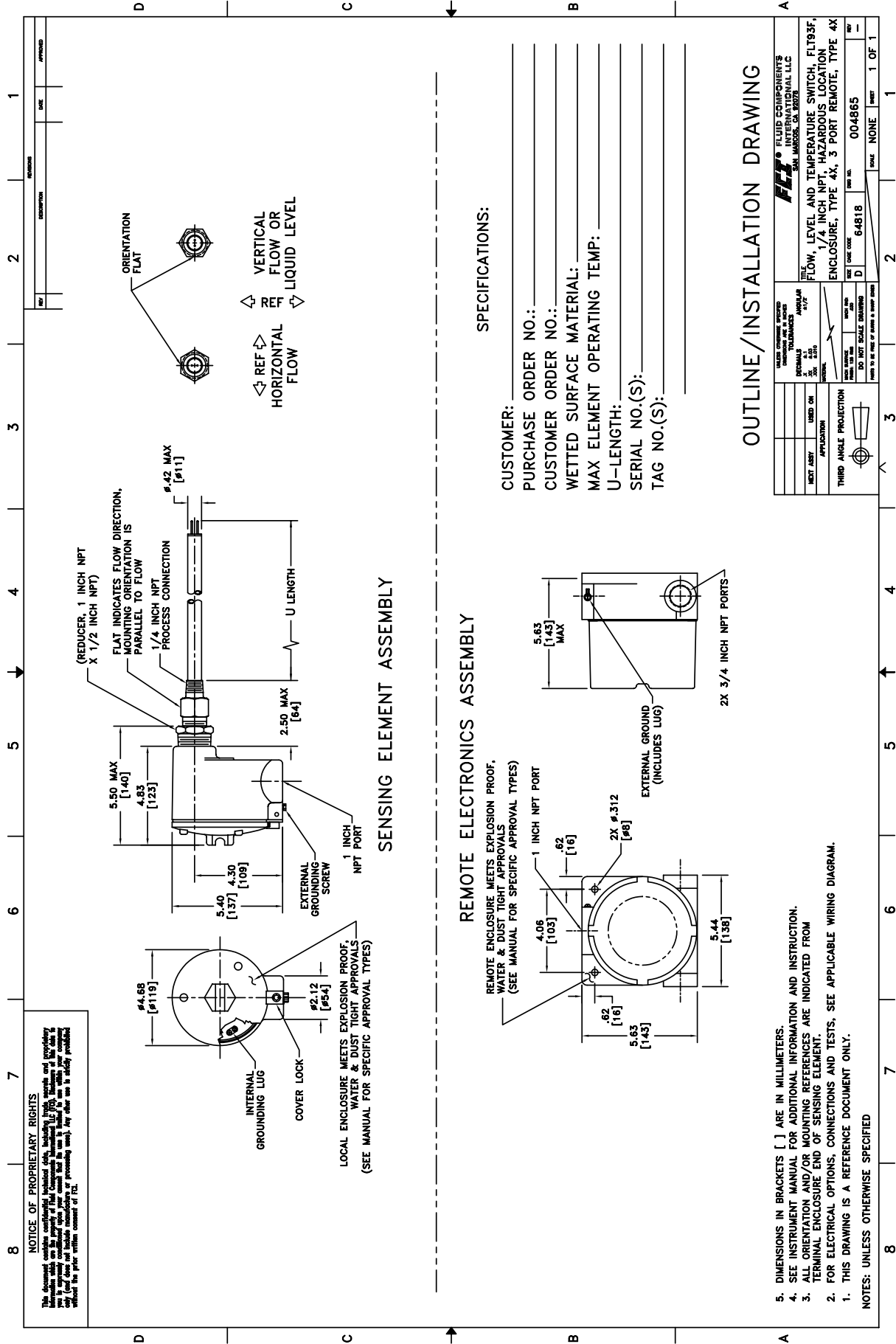

FLT93F Style Head : 1/4" NPT with Local Hazardous Location Type 4X Enclosure : 3 Port Remote Type 4X

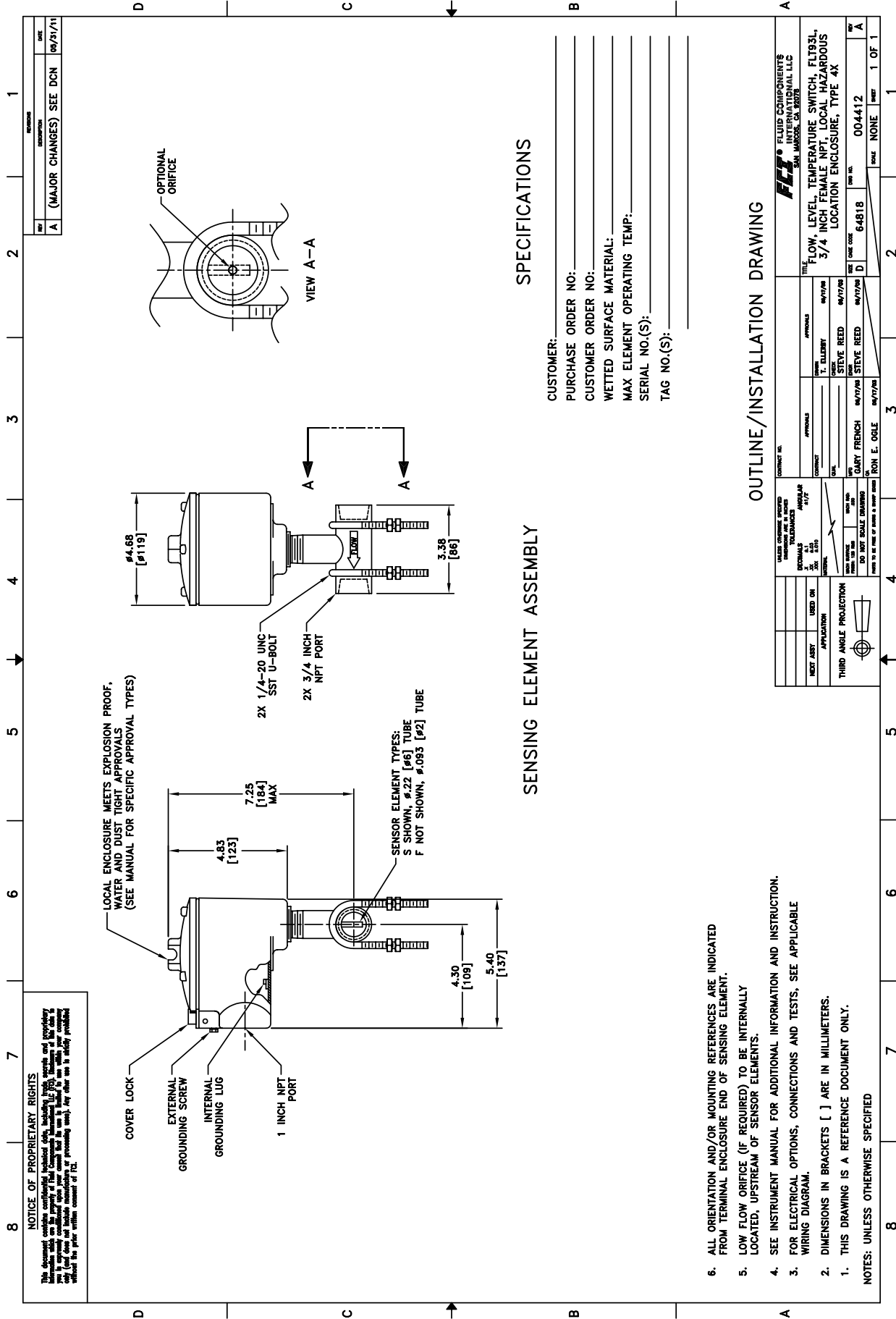

FLT93L : 3/4" NPT with Local Hazardous Location Type 4X Enclosure

NOTICE OF PROPRIETARY RIGHTS
 This document contains confidential technical data, including trade secrets and proprietary information, which are the property of Fluid Components International, LLC (FCI). It is intended for the use of the recipient only and does not include manufacturing or assembly instructions. Any other use is strictly prohibited without the prior written consent of FCI.

6. ALL ORIENTATION AND/OR MOUNTING REFERENCES ARE INDICATED FROM TERMINAL ENCLOSURE END OF SENSING ELEMENT.
5. LOW FLOW ORIFICE (IF REQUIRED) TO BE INTERNALLY LOCATED, UPSTREAM OF SENSOR ELEMENTS.
4. SEE INSTRUMENT MANUAL FOR ADDITIONAL INFORMATION AND INSTRUCTION. FOR ELECTRICAL OPTIONS, CONNECTIONS AND TESTS, SEE APPLICABLE WIRING DIAGRAM.
3. DIMENSIONS IN BRACKETS [] ARE IN MILLIMETERS.
1. THIS DRAWING IS A REFERENCE DOCUMENT ONLY.

NOTES: UNLESS OTHERWISE SPECIFIED

SPECIFICATIONS

CUSTOMER: _____
 PURCHASE ORDER NO: _____
 CUSTOMER ORDER NO: _____
 WETTED SURFACE MATERIAL: _____
 MAX ELEMENT OPERATING TEMP: _____
 SERIAL NO.(S): _____
 TAG NO.(S): _____

OUTLINE/INSTALLATION DRAWING

TITLE: FLOW, LEVEL, TEMPERATURE SWITCH, FLT93L, 3/4 INCH NPT, LOCAL HAZARDOUS LOCATION ENCLOSURE, TYPE 4X DATE: 06/17/08 DRAWN BY: STEVE REED CHECKED BY: STEVE REED APPROVED BY: RON E. OGLE		CONTRACT NO.: 0044412 SHEET NO.: 1 OF 1	
APPROVALS: DATE: 06/17/08 BY: STEVE REED		APPROVALS: DATE: 06/17/08 BY: STEVE REED	
APPROVALS: DATE: 06/17/08 BY: RON E. OGLE		APPROVALS: DATE: 06/17/08 BY: RON E. OGLE	

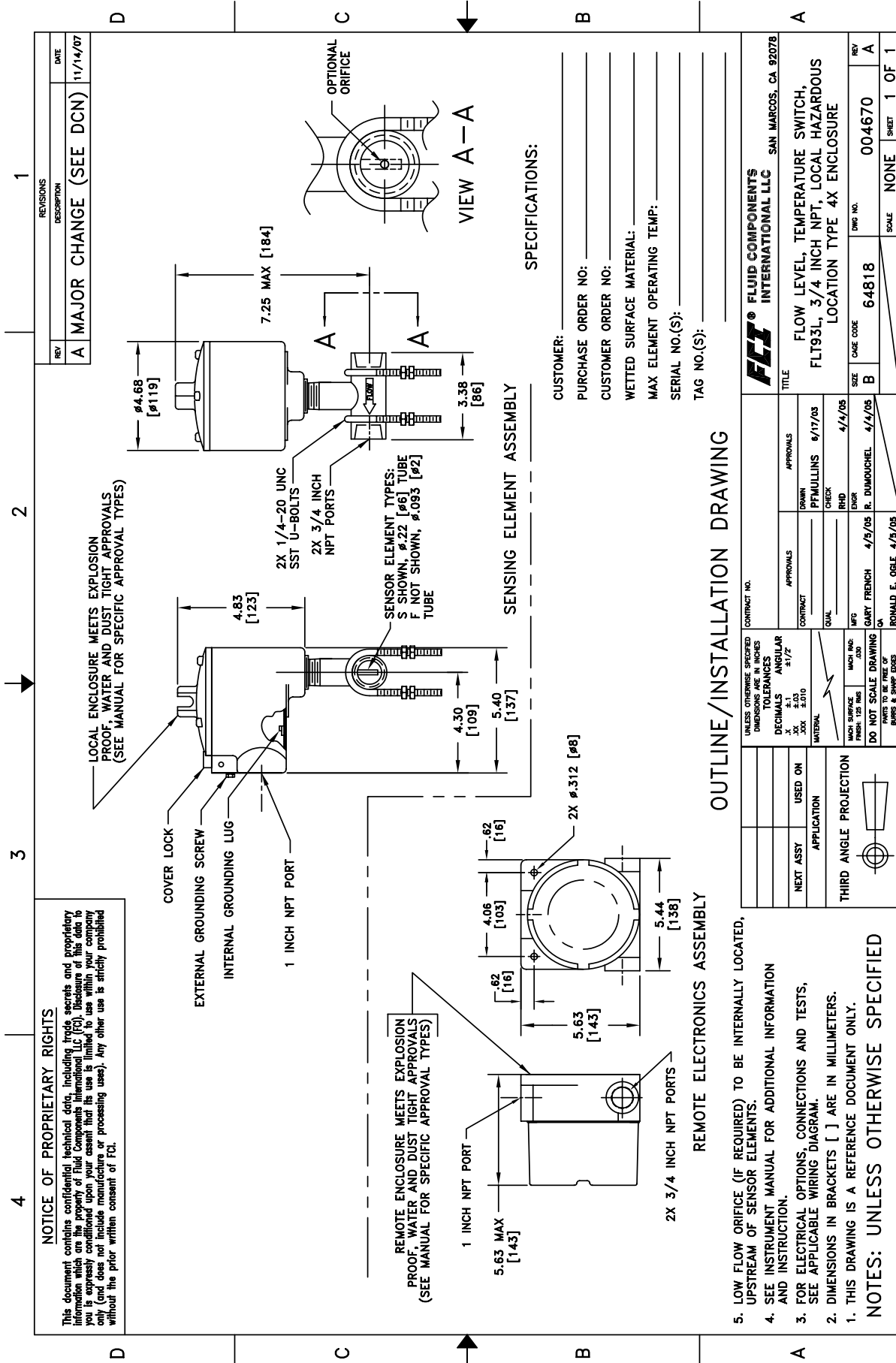

REV	DESCRIPTION	DATE
A	MAJOR CHANGE (SEE DON)	11/14/07

LOCAL ENCLOSURE MEETS EXPLOSION PROOF, WATER AND DUST TIGHT APPROVALS (SEE MANUAL FOR SPECIFIC APPROVAL TYPES)

REMOTE ENCLOSURE MEETS EXPLOSION PROOF, WATER AND DUST TIGHT APPROVALS (SEE MANUAL FOR SPECIFIC APPROVAL TYPES)

NOTICE OF PROPRIETARY RIGHTS
 This document contains confidential technical data, including trade secrets and proprietary information which are the property of Fluid Components International LLC (FCI). Disclosure of this data to you is expressly conditioned upon your assent that its use is limited to use within your company only (and does not include manufacture or processing uses). Any other use is strictly prohibited without the prior written consent of FCI.

SENSING ELEMENT ASSEMBLY

REMOTE ELECTRONICS ASSEMBLY

OUTLINE/INSTALLATION DRAWING

SPECIFICATIONS:
 CUSTOMER: _____
 PURCHASE ORDER NO: _____
 CUSTOMER ORDER NO: _____
 WETTED SURFACE MATERIAL: _____
 MAX ELEMENT OPERATING TEMP: _____
 SERIAL NO.(S): _____
 TAG NO.(S): _____

- LOW FLOW ORIFICE (IF REQUIRED) TO BE INTERNALLY LOCATED, UPSTREAM OF SENSOR ELEMENTS.
- SEE INSTRUMENT MANUAL FOR ADDITIONAL INFORMATION AND INSTRUCTION.
- FOR ELECTRICAL OPTIONS, CONNECTIONS AND TESTS, SEE APPLICABLE WIRING DIAGRAM.
- DIMENSIONS IN BRACKETS [] ARE IN MILLIMETERS.
- THIS DRAWING IS A REFERENCE DOCUMENT ONLY.

NOTES: UNLESS OTHERWISE SPECIFIED

FCI FLUID COMPONENTS INTERNATIONAL LLC SAN MARCOS, CA 92078	
TITLE	FLOW LEVEL, TEMPERATURE SWITCH, FLT93L, 3/4 INCH NPT, LOCAL HAZARDOUS LOCATION TYPE 4X ENCLOSURE
CONTRACT NO.	
APPROVALS	
DESIGNED BY	PFMULLINS 8/17/05
CHECKED BY	
DATE	4/1/05
MFG	GARY FRENCH 4/5/05 R. DUMOUCHEL 4/1/05
SIZE	CODE CODE 64818
DWG NO.	004670
REV	A
SCALE	NONE
SHEET	1 OF 1

UNLESS OTHERWISE SPECIFIED DIMENSIONS ARE IN INCHES	APPROVALS
DECIMALS .1 .2 .3 .4 .5 .6 .7 .8 .9	DESIGNED BY
FRACTIONS 1/16 1/8 1/4 1/2 3/4 1	CHECKED BY
ANGULAR ±1/2°	DATE
MATERIAL	MFG
MAX SURFACE FINISH: 125 RMS	DATE
MAX HOLE FINISH: 250	DATE
DO NOT SCALE DRAWING	DATE
PARTS TO BE FREE OF BURRS & SHARP EDGES	DATE
	RONALD E. OGLE 4/5/05

NEXT ASSY	USED ON
APPLICATION	
THIRD ANGLE PROJECTION	

1 2 3 4

FLT93L : 3/4" NPT with Local Hazardous Location Type 4X Enclosure : 3 Port Remote Type 4X

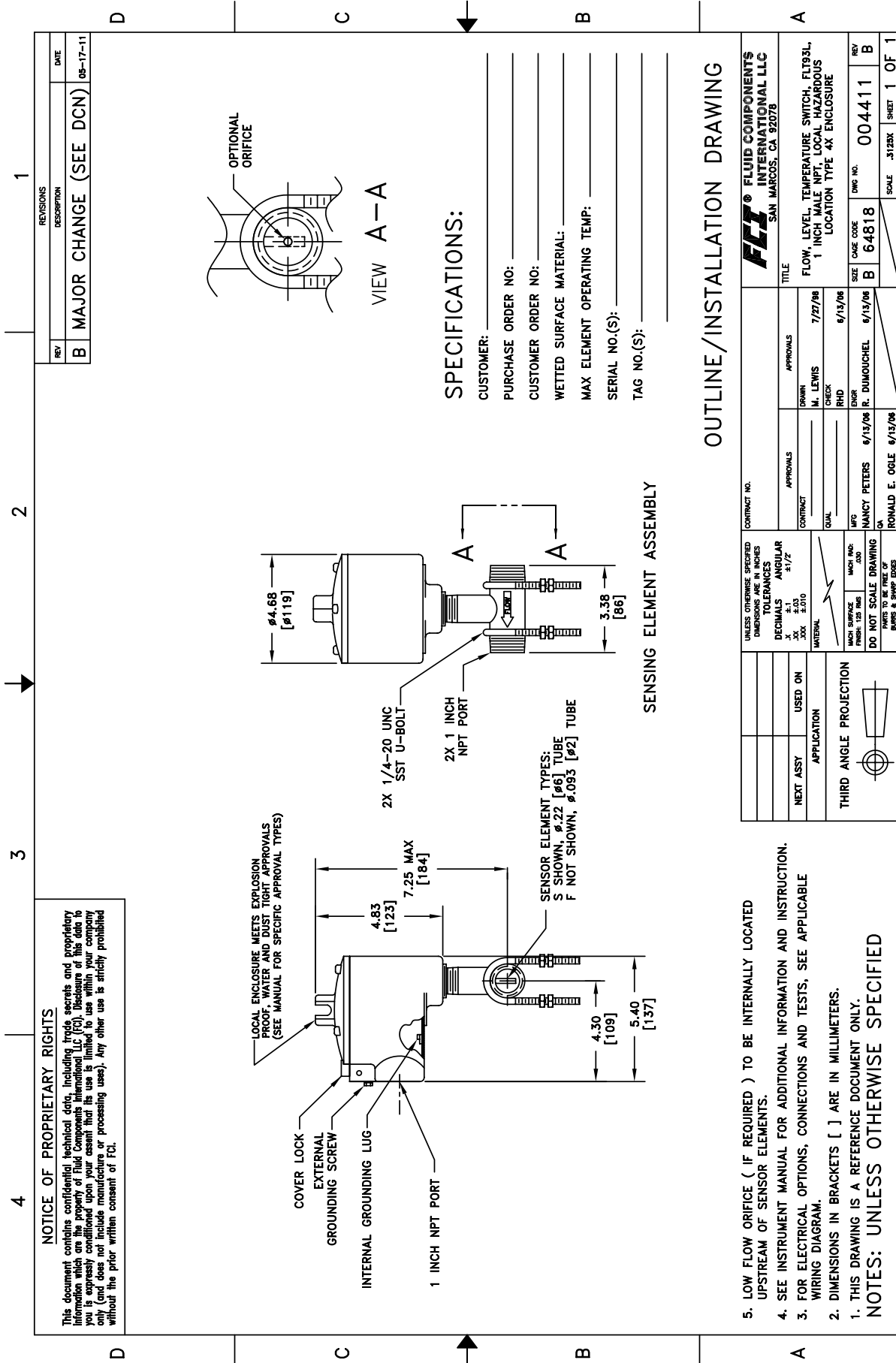

FLT93L : 1" NPT with Local Hazardous Location Type 4X Enclosure

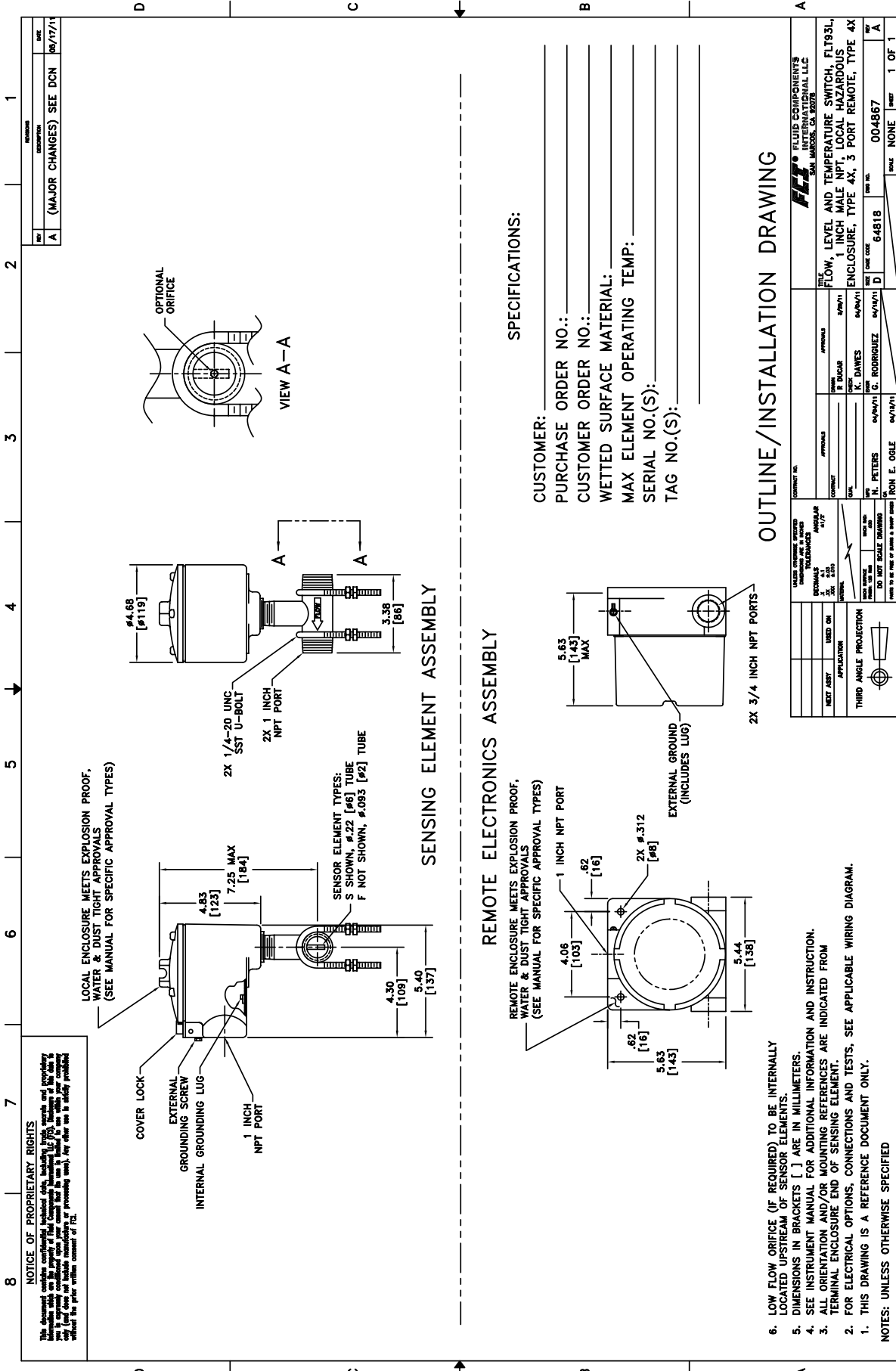

FLT93L : 1" NPT with Local Hazardous Location Type 4X Enclosure : 3 Port Remote Type 4X

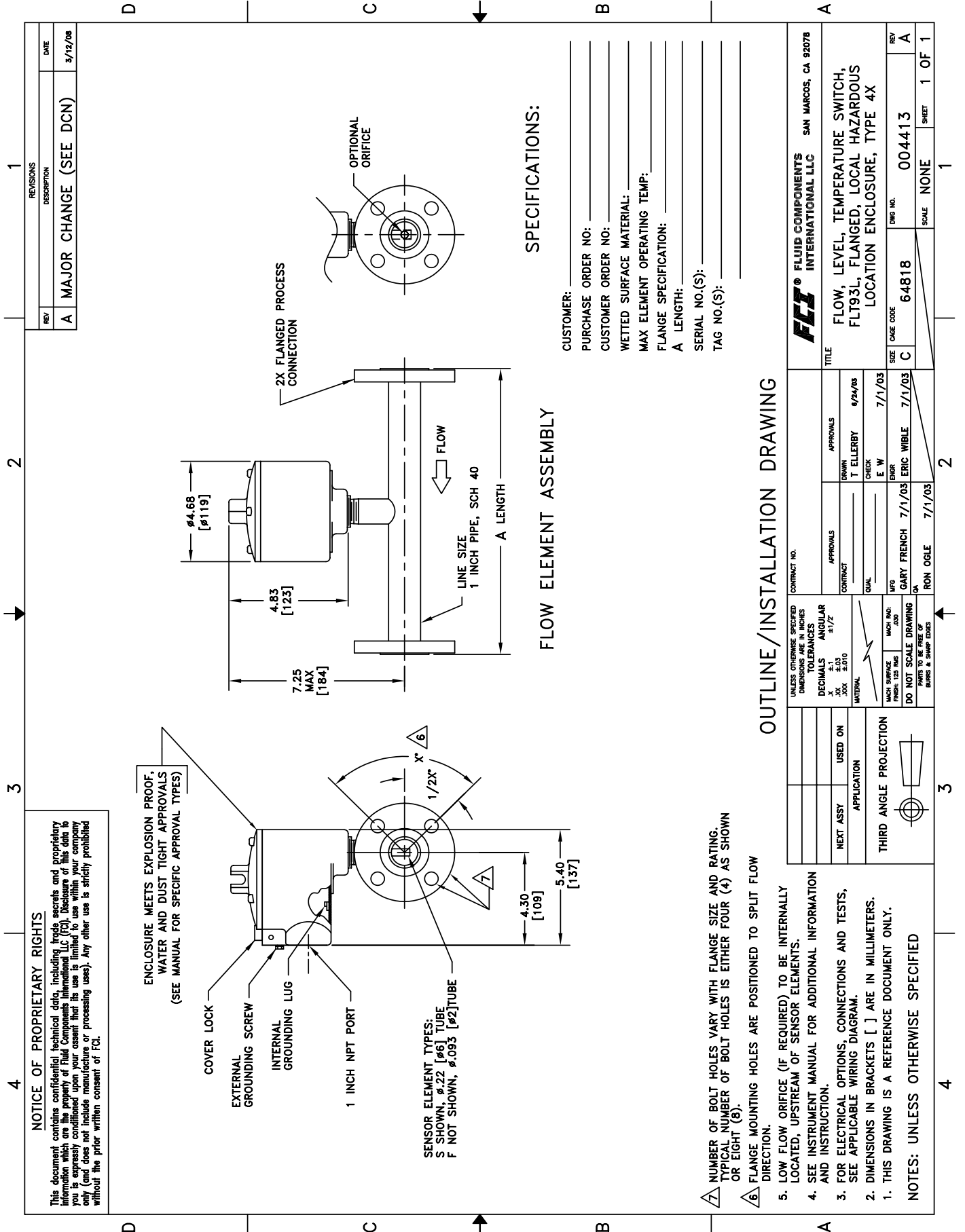

NOTICE OF PROPRIETARY RIGHTS

This document contains confidential technical data, including trade secrets and proprietary information which are the property of Fluid Components International LLC (FCI). Disclosure of this data to you is expressly conditioned upon your consent that its use is limited to use within your company only (and does not include manufacture or processing uses). Any other use is strictly prohibited without the prior written consent of FCI.

ENCLOSURE MEETS EXPLOSION PROOF, WATER AND DUST TIGHT APPROVALS (SEE MANUAL FOR SPECIFIC APPROVAL TYPES)

SENSOR ELEMENT TYPES:
S SHOWN, ϕ .22 [ϕ 6] TUBE
F NOT SHOWN, ϕ .093 [ϕ 2] TUBE

FLOW ELEMENT ASSEMBLY

SPECIFICATIONS:

CUSTOMER: _____
PURCHASE ORDER NO: _____
CUSTOMER ORDER NO: _____
WETTED SURFACE MATERIAL: _____
MAX ELEMENT OPERATING TEMP: _____
FLANGE SPECIFICATION: _____
A LENGTH: _____
SERIAL NO.(S): _____
TAG NO.(S): _____

OUTLINE/INSTALLATION DRAWING

- 1. NUMBER OF BOLT HOLES VARY WITH FLANGE SIZE AND RATING. TYPICAL NUMBER OF BOLT HOLES IS EITHER FOUR (4) AS SHOWN OR EIGHT (8).
 - 2. FLANGE MOUNTING HOLES ARE POSITIONED TO SPLIT FLOW DIRECTION.
 - 3. LOW FLOW ORIFICE (IF REQUIRED), TO BE INTERNALLY LOCATED, UPSTREAM OF SENSOR ELEMENTS.
 - 4. SEE INSTRUMENT MANUAL FOR ADDITIONAL INFORMATION AND INSTRUCTION.
 - 5. FOR ELECTRICAL OPTIONS, CONNECTIONS AND TESTS, SEE APPLICABLE WIRING DIAGRAM.
 - 6. DIMENSIONS IN BRACKETS [] ARE IN MILLIMETERS.
 - 7. THIS DRAWING IS A REFERENCE DOCUMENT ONLY.
- NOTES: UNLESS OTHERWISE SPECIFIED

UNLESS OTHERWISE SPECIFIED DIMENSIONS ARE IN INCHES		CONTRACT NO.		FCI® FLUID COMPONENTS INTERNATIONAL LLC SAN MARCOS, CA 92078	
TOLERANCES	APPROVALS	APPROVALS	TITLE	SIZE	REV
DECIMALS ±.1	DRAWN T. ELLERBY	CHECK E. W.	FLOW, LEVEL, TEMPERATURE SWITCH, FLT93L, FLANGED, LOCAL HAZARDOUS LOCATION ENCLOSURE, TYPE 4X	CASE CODE C	004413
ANGULAR ±1/2°	CONTRACT	DATE 7/1/03	DATE 7/1/03	DWG NO. 64818	SHEET 1 OF 1
MATERIAL	QUAL	DATE 7/1/03	DATE 7/1/03	SCALE NONE	
MACH SURFACE FINISH: 125 RMS	DATE 7/1/03	DATE 7/1/03	DATE 7/1/03		
DO NOT SCALE DRAWING	DATE 7/1/03	DATE 7/1/03	DATE 7/1/03		
PAINTS TO BE FREE OF BARRIS & SHARP EDGES	DATE 7/1/03	DATE 7/1/03	DATE 7/1/03		
APPLICATION	DATE 7/1/03	DATE 7/1/03	DATE 7/1/03		
THIRD ANGLE PROJECTION	DATE 7/1/03	DATE 7/1/03	DATE 7/1/03		

FLT93L : Flanged with Local Hazardous Location Type 4X Enclosure

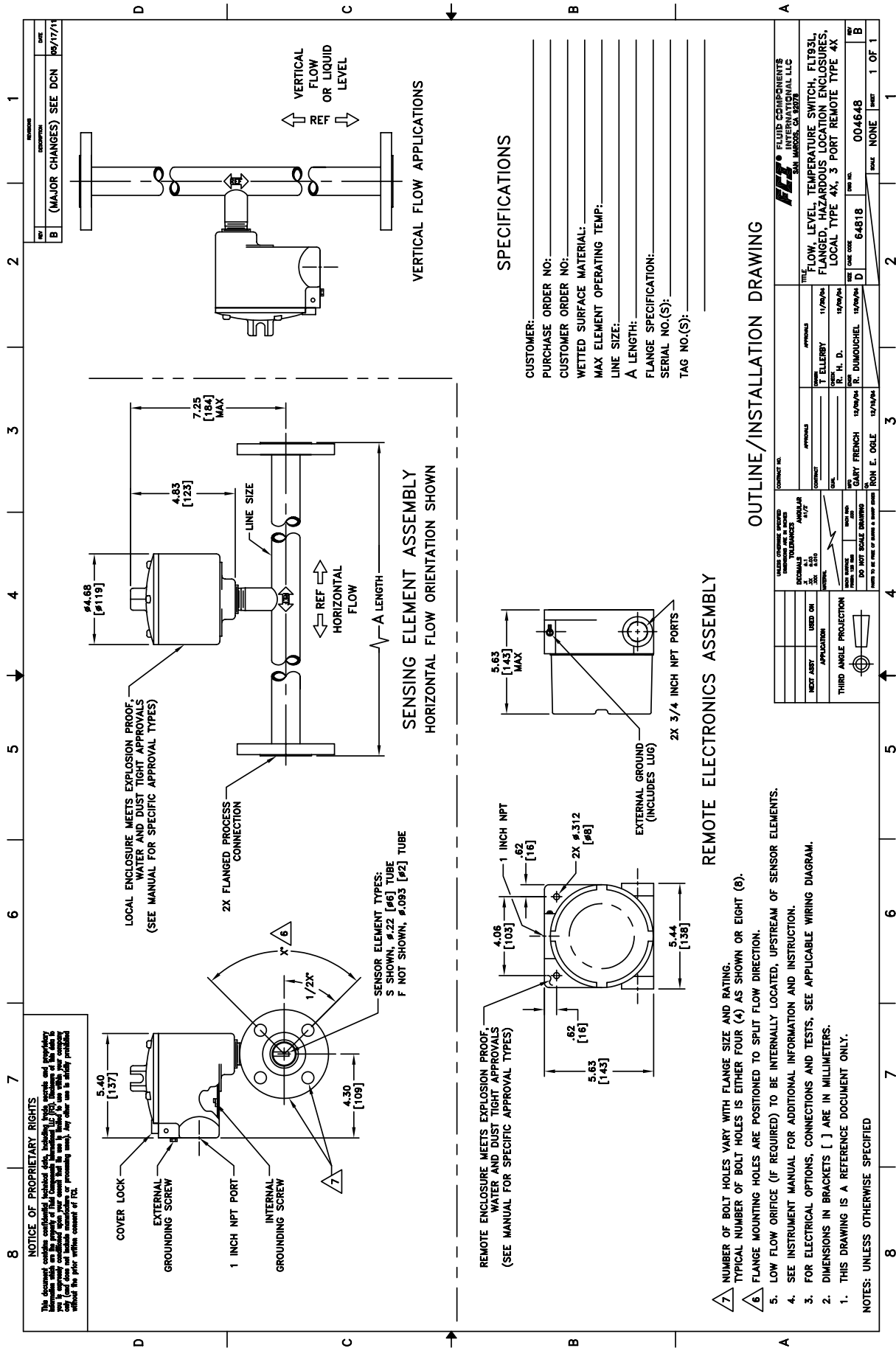

FLT93L : Flanged with Local Hazardous Location Type 4X Enclosure : 3 Port Remote Type 4X

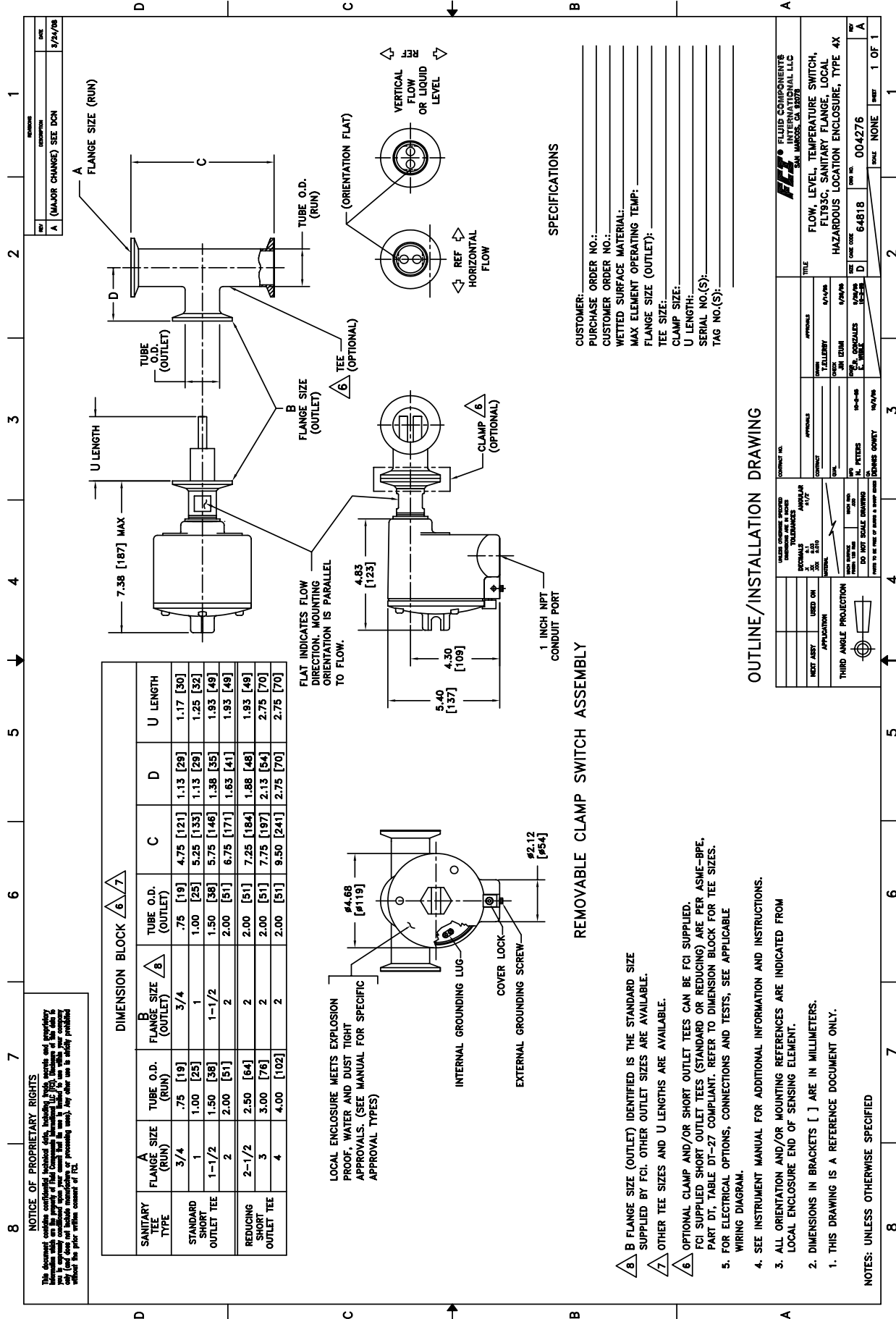

FLT93C : Sanitary Flange with Local Hazardous Location Type 4X Enclosure

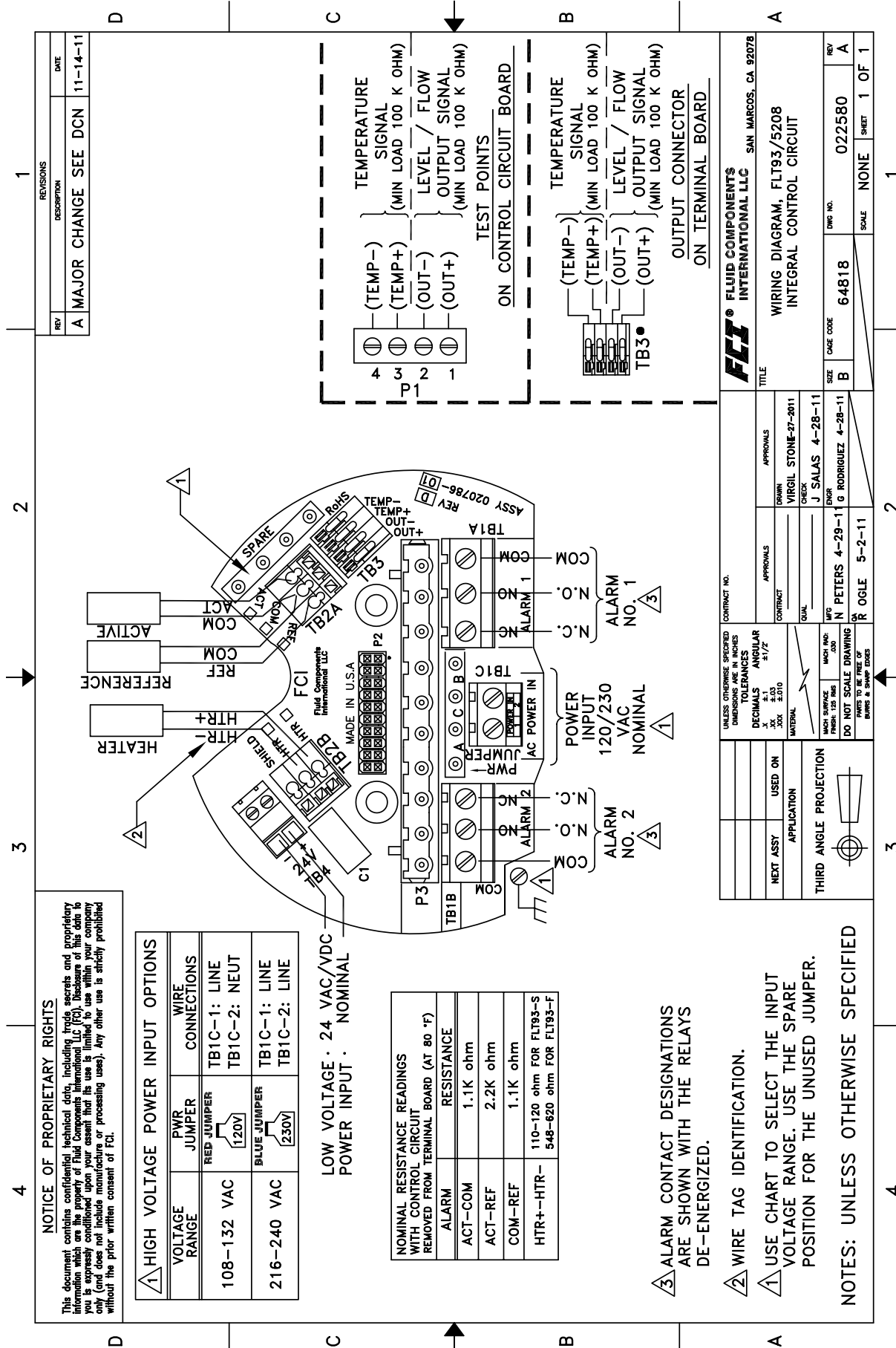

NOTICE OF PROPRIETARY RIGHTS

This document contains confidential technical data, including trade secrets and proprietary information which are the property of Fluid Components International LLC (FCI). Disclosure of this data to you is expressly conditioned upon your consent that its use is limited to use within your company only (and does not include manufacturing or processing uses). Any other use is strictly prohibited without the prior written consent of FCI.

REV	DESCRIPTION	DATE
A	MAJOR CHANGE SEE DCN 11-14-11	11-14-11

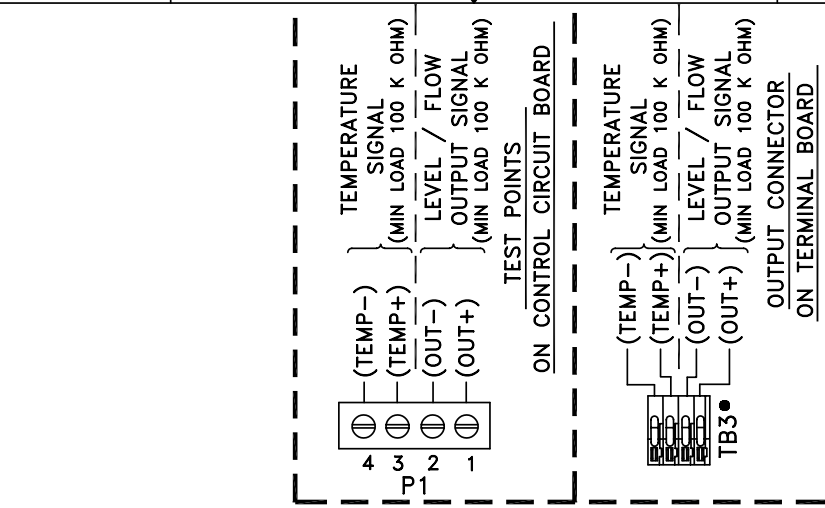

REV	DESCRIPTION	DATE
A	MAJOR CHANGE SEE DCN 11-14-11	11-14-11

UNLESS OTHERWISE SPECIFIED DIMENSIONS ARE IN INCHES	CONTRACT NO.
TOLERANCES DECIMALS .005 ANGULAR ±1/2°	020786-01
MATERIAL	APPROVALS
DRUG NO. 5-2-11	APPROVALS
DO NOT SCALE DRAWING	APPROVALS
DATE 5-2-11	APPROVALS
DRAWN BY R. OGLE	APPROVALS
CHECKED BY G. RODRIGUEZ	APPROVALS
ENGR. BY J. SALAS	APPROVALS
DATE 4-28-11	APPROVALS
SCALE NONE	APPROVALS
SHEET 1 OF 1	APPROVALS

FLT93 Surface Mount : Local Wiring Diagram

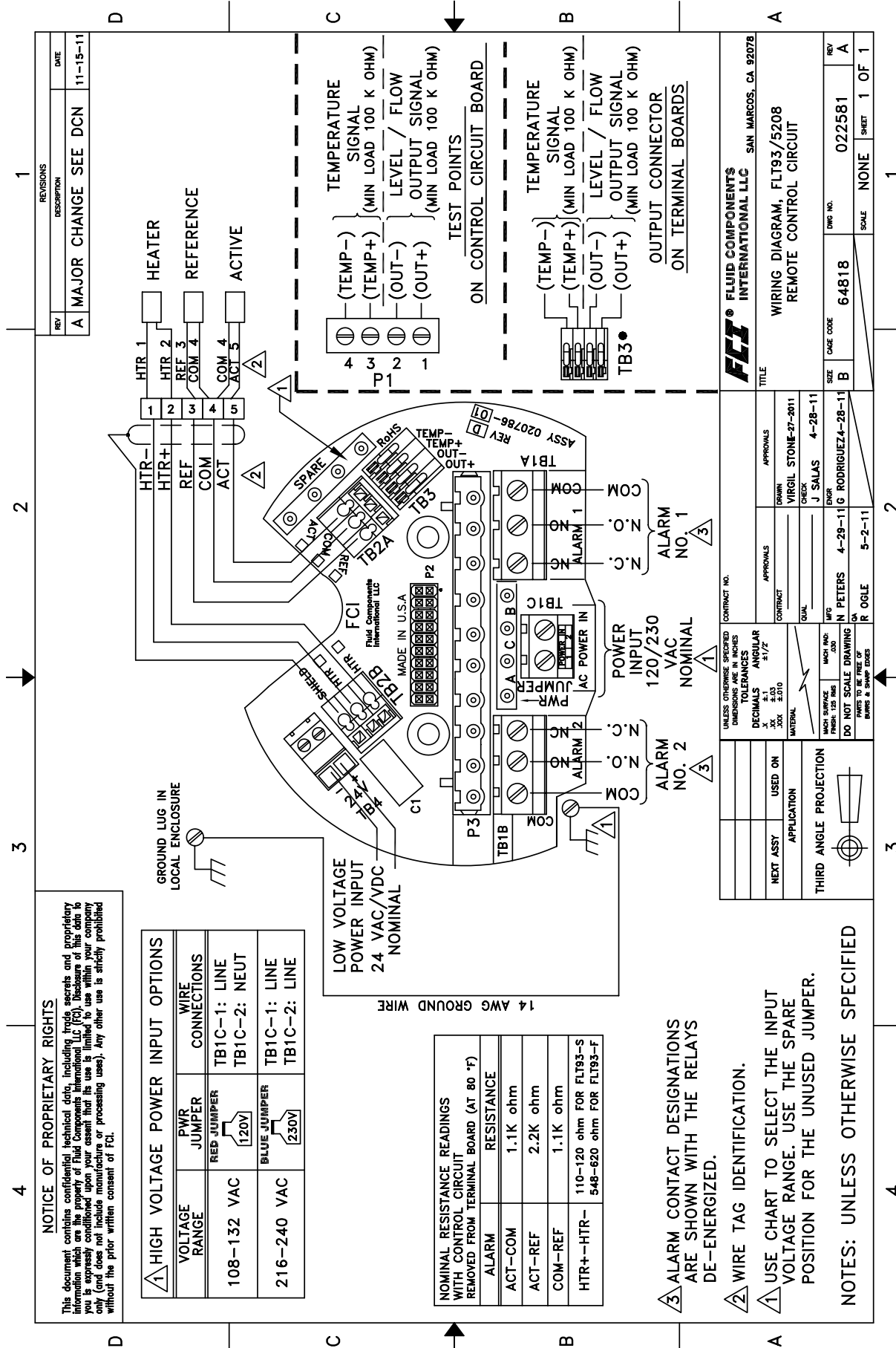

FLT93 Surface Mount : Remote Wiring Diagram

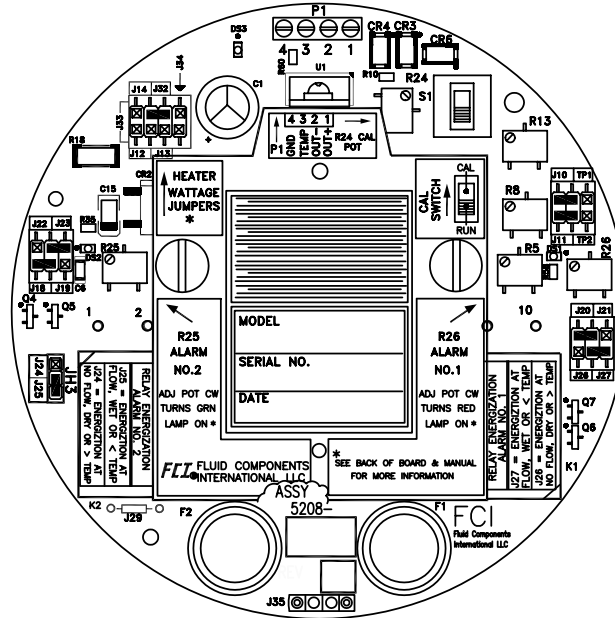

1 **FIGURE 1**
COMPONENT SIDE

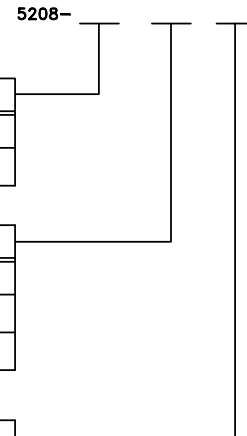

PART NUMBER	INPUT POWER CONFIGURATION BLOCK	DES
020787-01	STD: NORMAL LINE A.C. 120 VAC, 240 VAC, 24 VDC, 24 VAC	A
020788-01	LOW LINE A.C. 100 VAC, 200 VAC, 24 VDC, 24 VAC	B

PART NUMBER	RELAY CONTACT RATING CONFIGURATION BLOCK	DES
020789-01	STD: 6 AMP AT 120 VAC EPOXY SEALED	1
020790-01	EXTERNAL RELAYS 18 VDC SIGNAL OUTPUT	2
020791-01	0.5 AMP AT 120 VAC HERMETICALLY SEALED	3

MODEL	PART NUMBER	HEATER WATTAGE CONTROL	DES
-S ELEMENT	020792-01	VARIABLE	A
	020793-01	FIXED (171°c F DELTA T MAX)	B
-F ELEMENT	020794-01	VARIABLE	C
	020795-01	FIXED (171°c F DELTA T MAX)	D

- 8. TEST PROCEDURE 04EN00594.
- 7. SCHEMATIC NO. 020780-01.
- 6. SEE THE OP SHEET FOR ASSEMBLY INSTRUCTIONS.
- ⚠ RELAYS ARE RATED FOR RESISTIVE LOADS ONLY.
- ⚠ FOR USE WITH A SEPARATELY MOUNTED RELAY ASSEMBLY (P/N 705649) THE CONTROL CIRCUIT PROVIDES A SWITCHING VOLTAGE AT TERMINALS 3 AND 4 FOR ALARM NO. 1 AND 5 AND 6 FOR ALARM NO. 2
- ⚠ THE RELAY ASSEMBLY HAS 2 EACH DPDT RELAY WITH A CHOICE OF RATINGS, AND CASES. PLASTIC SEALED CASE 2 AMP AT 115 VAC OR 10 AMPS AT 115 VAC RESISTIVE. NUCLEAR QUALIFIED 10 AMP 115 VAC RELAY WITH PLASTIC DUST COVER. HERMETICALLY SEALED RELAYS ARE 0.3 OR 0.5 AMP AT 115 VAC.
- ⚠ SUB ASSEMBLY 020783-01 INCLUDED AS PART OF THIS OPTION.
- 2. ALL PLUGGABLE JUMPERS ARE SHOWN IN THE DEFAULT POSITIONS. DEFAULT SETTINGS ARE AS FOLLOWS:
HEATER WATTAGE CONTROL = 0.75 WATTS (J13) FOR THE FLT-S ELEMENT;
0.25 WATTAGE (J14) FOR THE F-F ELEMENT.
ALARM NO. 1 SET TO MONITOR FLOW OR LEVEL SIGNAL (J20)
ALARM NO. 2 SET TO MONITOR TEMPERATURE SIGNAL (J19)
ALARM NO. 1 RELAY ENERGIZED AT FLOW OR WET (J27)
ALARM NO. 2 RELAY ENERGIZED AT BELOW TEMPERATURE (J25)
ALARM QUANTITY JUMPER SET FOR 2 EA (J23)
- ⚠ SEE FIGURE ONE FOR CLARIFICATION OF THE REFERENCE DESIGNATOR LOCATIONS OF THE SUBLEVEL PARTS LISTS.

NOTES: UNLESS OTHERWISE SPECIFIED

C01021-1-2, ref. dwg.# 5208 Rev. A

FLT93 PWB Module : 5208

APPENDIX B GLOSSARY

Abbreviations

Delta-R (DR)	Differential Resistance
Delta-T (DT)	Differential Temperature
DMM	Digital Multimeter
DPDT	Double Pole Double Throw
FCI	Fluid Components Intl
HTR	Heater
LED	Light Emitting Diode
POT	Potentiometer
RA	Return Authorization
RTD	Resistance Temperature Detector
SFPS	Standard Feet Per Second
SPDT	Single Pole Double Throw

Definitions

Active RTD	The sensing element that is heated by the heater. The active RTD is cooled due to increases in the process fluid flow rate or density (level sensing).
Differential resistance	
Delta-R (DR)	The difference in resistance between the active and reference RTDs.
Differential temperature	
Delta-T (DT)	The difference in temperature between the active and reference RTDs.
Heater (HTR)	The part of the sensing element that heats the active RTD.
Local enclosure	The enclosure attached to the sensing element. (Usually contains the control circuit and mounting socket.)
Reference RTD	The part of the sensing element that senses the process media temperature.
Remote enclosure	An optional protective enclosure for the control circuit. Used when the control circuit must be located away from the sensing element.
Resistance Temperature Detector (RTD)	A sensor whose resistance changes proportionally to temperature changes.
Sensing element	The transducer portion of the instrument. The sensing element produces an electrical signal that is related to the flow rate, density (level sensing), and temperature of the process media.
Thermowell	The part of the sensing element that protects the heater and RTDs from the process fluid.
Turndown	The ratio of the upper to lower flow rate values.

INTENTIONALLY LEFT BLANK

APPENDIX C APPROVAL INFORMATION

EC Information



EC DECLARATION OF CONFORMITY Model FLT93

We, *Fluid Components Intl*, located at 1755 La Costa Meadows Drive, San Marcos , California 92078-5115 USA, declare under our sole responsibility that the **FLT Series FlexSwitch Product Family**, models FLT93-S, FLT93-F and FLT93-L to which this declaration relates, are in conformity with the following Standards and Directives:

ATEX Directive 94/9/EC

KEMA Quality B.V. (0344): Utrechtseweg 310, 6812 AR, Arnhem, The Netherlands.

EC-Type Examination Certificate Number: KEMA 02ATEX2166 satisfies EN60079-0:2004, EN61241-0:2006, EN60079-1:2004, EN61241-1:2004 and 50281-1-1:1998 requirements.

EMC Directive 89/336/EEC of May 3, 1989 of the European Union.

Immunity specifications: EN 50082-2: 1995; EN 61000-4-2 1995; EN 61000-4-4 1995; EN 61000-4-6 1996; EN 61000-6-2 1999; ENV 50140 1993 and ENV 50204

Emissions specifications: EN55022 Class B and CISPR 22 Class B

Pressure Equipment Directive (PED) 97/23/EC.

The FLT93-S/-F Models do not have a pressure bearing housing and are therefore not considered as pressure equipment by themselves according to article 1, section 2.1. The Model FLT93-L is in conformity with the sound engineering practices as defined in the Pressure Equipment Directive (PED) 97/23/EC article 3, paragraph 3.

*Issued at San Marcos, California USA
February, 2008*

 Eric Wible
2008.03.04
07:43:43
-08'00'

Eric Wible, Engineering Manager

1755 La Costa Meadows Dr. San Marcos CA 92078 USA ☎ Phone: 760.744.6950 ☎ Toll free: 800.854.1993 ☎ Fax: 760.736.6250
European Office: Persephonestraat 3-01, 5047 TT Tilburg, The Netherlands ☎ Phone: 31.13.5159989 ☎ Fax: 31.13.5799036
Web: www.fluidcomponents.com ☎ Email: info@fluidcomponents.com
ISO9001:2000/AS9100 Certified

Doc No. 23EN000007E

INTENTIONALLY LEFT BLANK

Safety Instructions for the use of the FLT93 Flowswitch in Hazardous Areas
Approval KEMA 02 ATEX 2166 for II 2G Ex d IIC T4
II 2D Ex tD A21 T 100°C IP66

Dansk	Sikkerhedsforskrifter	Italiano	Normative di sicurezza
Deutsch	Sicherheitshinweise	Nederlands	Veiligheidsinstructies
English	Safety instructions	Português	Normas de segurança
Υπ	Υπ_δεί_εις ασφαλείας	Español	Instrucciones de seguridad
Suomi	Turvallisuusohjeet	Svenska	Säkerhetsanvisningar
Français	Consignes de sécurité		

DK**Dansk- Sikkerhedsforskrifter**

Disse sikkerhedsforskrifter gælder for Fluid Components, FLT93 Flowswitch EF-typeafprøvningsattest-nr. KEMA 02 ATEX 2166 (attestens nummer på typeskiltet) er egnet til at blive benyttet i eksplosiv atmosfære kategori II 2 G.

- 1) Ex-anlæg skal principielt opstilles af specialiseret personale.
- 2) FLT93 Flowswitch skal jordforbindes.
- 3) Klemmerne og elektronikken er monteret i et hus, som er beskyttet af en eksplosionssikker kapsling med følgende noter:
 - Gevindspalten mellem huset og låget er på en sådan måde, at ild ikke kan brede sig inden i det.
 - Ex-„d“ tilslutningshuset er forsynet med et 1" NPT og/eller 3/4" NPT gevind for montering af en Ex-„d“ kabelindføring, der er atteresteret iht. EN50018/EN60079-1
 - Det er vigtigt at sørge for, at forsyningsledningen er uden spænding eller eksplosiv atmosfære ikke er til stede, før låget åbnes og når låget er åbent på „d“ huset (f.eks. ved tilslutning eller servicearbejde).
 - Låget på „d“ huset skal være skruet helt ind, når apparatet er i brug. Det skal sikres ved at dreje en af låseskruerne på låget ud.

D**A****Deutsch-Sicherheitshinweise**

Diese Sicherheitshinweise gelten für die Fluid Components, FLT93 Flowswitch gemäß der EG-Baumusterprüfbescheinigung Nr. KEMA 02 ATEX 2166 (Bescheinigungsnummer auf dem Typschild) der Kategorie II 2 G.

- 1) Die Errichtung von Ex-Anlagen muss grundsätzlich durch Fachpersonal vorgenommen werden.
- 2) Der FLT93 Flowswitch muß geerdet werden.
- 3) Die Klemmen und Elektronik sind in einem Gehäuse in der Zündschutzart druckfeste Kapselung („d“) eingebaut.
 - Der Gewindespalt zwischen dem Gehäuse und dem Deckel ist ein zünddurchschlagsicherer Spalt.
 - Das Ex-„d“ Anschlussgehäuse besitzt ein 3/4“ und/oder 1“ NPT Gewinde für den Einbau einer nach EN50018/EN60079-1 bescheinigten Ex-„d“ Kabeleinführung.
 - Es ist sicherzustellen, dass vor dem Öffnen und bei geöffnetem Deckel des „d“ Gehäuses (z.B. bei Anschluss oder Service- Arbeiten) entweder die Versorgungsleitung spannungsfrei oder keine explosionsfähige Atmosphäre vorhanden ist.
 - Der Deckel des „d“ Gehäuses muss im Betrieb bis zum Anschlag hineingedreht sein. Er ist durch eine der Deckelarretierungsschrauben zu sichern.

GB**IRL****English- Safety instructions**

These safety instructions are valid for the Fluid Components, FLT93 Flowswitch to the EC type approval certificate no. KEMA 02 ATEX 2166 (certificate number on the type label) for use in potentially explosive atmospheres in Category II 2 G.

- 1) The installation of Ex-instruments must be made by trained personnel.
- 2) The FLT93 Flowswitch must be grounded.
- 3) The terminals and electronics are installed in a flame proof and pressure-tight housing with following notes:
 - The gap between the housing and cover is an ignition-proof gap.
 - The Ex-„d“ housing connection has a 1" and/or 3/4" NPT cable entry for mounting an Ex-d cable entry certified acc. to EN50018/EN60079-1.
 - Make sure that before opening the cover of the Ex" d" housing, the power supply is disconnected or there is no explosive atmosphere present (e.g. during connection or service work).
 - During normal operation: The cover of the "d" housing must be screwed in completely and locked by tightening one of the cover locking screws.

GR**Υπ_δεί_εις ασφαλείας**

Αυτές οι οδηγίες ασφαλείας ισχύουν για τα Ροόμετρα της Fluid Components τύπου FLT93 Flowswitch που φέρουν Πιστοποιητικό Εγκρίσεων Ευρωπαϊκής Ένωσης, με αριθμό πιστοποίησης KEMA 02 ATEX 2166 (ο αριθμός πιστοποίησης βρίσκεται πάνω στην ετικέτα τύπου του οργάνου) για χρήση σε εκρηκτικές ατμόσφαιρες της κατηγορίας II 2 G.

- 1) Η εγκατάσταση των οργάνων με αντιεκρηκτική προστασία πρέπει να γίνει από εξειδικευμένο προσωπικό.
- 2) Το όργανο τύπου FLT93 Flowswitch πρέπει να είναι γειωμένο.
- 3) Τα τερματικά ηλεκτρικών συνδέσεων (κλέμες) και τα ηλεκτρονικά κυκλώματα είναι εγκατεστημένα σε περίβλημα αντιεκρηκτικό και αεροστεγές σύμφωνα με τις ακόλουθες παρατηρήσεις:
 - Το κενό ανάμεσα στο περίβλημα και στο κάλυμμα είναι τέτοιο που αποτρέπει την διάδοση σπινθήρα.
 - Το “Ex-d” αντιεκρηκτικό περίβλημα, έχει ανοίγματα εισόδου καλωδίου με διάμετρο $\frac{3}{4}$ ή/και 1 ίντσα NPT, κατάλληλα για τοποθέτηση υποδοχής αντιεκρηκτικού καλωδίου πιστοποιημένης κατά EN50018/EN60079-1
 - Βεβαιωθείτε ότι πριν το άνοιγμα καλύμματος του του “Ex-d” αντιεκρηκτικού περιβλήματος, η τάση τροφοδοσίας είναι αποσυνδεδεμένη ή ότι δεν υφίσταται στη περιοχή εκρηκτική ατμόσφαιρα (π.χ. κατά τη διάρκεια της σύνδεσης ή εργασιών συντήρησης)
 - Κατά τη διάρκεια ομαλής λειτουργίας: Το κάλυμα του “d” καλύμματος αντιεκρηκτικού περιβλήματος πρέπει να είναι εντελώς βιδωμένο και ασφαλισμένο, σφίγγοντας μία από τις βίδες ασφαλείας του περιβλήματος.

FIN**Suomi - Turvallisuusohjeet**

Nämä turvallisuusohjeet koskevat Fluid Components, FLT93 Flowswitch EY-tyyppitarkastustodistuksen nro. KEMA 02 ATEX 2166 mukaisesti (todistuksen numero näkyy tyyppikilvestä) käytettäessä räjähdysvaarallisissa tiloissa luokassa II 2G.

- 1) Ex-laitteet on aina asennettava ammattihenkilökunnan toimesta.
- 2) FLT93 Flowswitch on maadoitettava.
- 3) Syöttöjännitteen kytkemisessä tarvittavat liittimet ja elektroniikka on asennettu koteloon jonka rakenne kestää räjähdyspaineen seuraavin lisäyksin:
 - Kotelon ja kannen välissä on räjähdysten purkausväli.
 - Ex-d liittäntäkotelossa on $\frac{3}{4}$ ” NPT ja/tai 1” NPT kierre EN50018/EN60079-1 mukaisen Ex-d kaapeliläpiviennin asennusta varten
 - Kun “d”-kotelon kansi avataan (esim. liittännän tai huollon yhteydessä), on varmistettava, että joko syöttöjohto on jännitteetön tai ympäristössä ei ole räjähtäviä aineita.
 - “d” -kotelon kansi on kierrettävä aivan kiinni käytön yhteydessä ja on varmistettava kiertämällä yksi kannen lukitusruuveista kiinni.

F**B****L****Consignes de sécurité**

Ces consignes de sécurité sont valables pour le modèle FLT93 Flowswitch de la société Fluid Components (FCI) conforme au certificat d'épreuves de type KEMA 02 ATEX 2166 (numéro du certificat sur l'étiquette signalétique) conçu pour les applications dans lesquelles un matériel de la catégorie II2G est nécessaire.

- 1) Seul un personnel spécialisé et qualifié est autorisé à installer le matériel Ex.
- 2) Les FLT93 Flowswitch doivent être reliés à la terre.
- 3) Les bornes pour le branchement de la tension d'alimentation et l'électronique sont logées dans un boîtier à enveloppe antidéflagrante avec les notes suivantes:
 - Le volume entre le boîtier et le couvercle est protégé en cas d'amorçage.
 - Le boîtier de raccordement Ex-d dispose d'un filetage $\frac{3}{4}$ ” NPT et/ou 1” NPT pour le montage d'un presse-étoupe Ex-d certifié selon la EN50018/EN60079-1.
 - Avant d'ouvrir le couvercle du boîtier « d » et pendant toute la durée où il le restera (pour des travaux de raccordement, d'entretien ou de dépannage par exemple), il faut veiller à ce que la ligne d'alimentation soit hors tension ou à ce qu'il n'y ait pas d'atmosphère explosive.
 - Pendant le fonctionnement de l'appareil, le couvercle du boîtier « d » doit être vissé et serré jusqu'en butée. La bonne fixation du couvercle doit être assurée en serrant une des vis d'arrêt du couvercle.

I**Italiano - Normative di sicurezza**

Queste normative di sicurezza si riferiscono ai Fluid Components, FLT93 Flowswitch secondo il certificato CE di prova di omologazione n° KEMA 02 ATEX 2166 (numero del certificato sulla targhetta d'identificazione) sono idonei all'impiego in atmosfere esplosive applicazioni che richiedono apparecchiature elettriche della Categoria II 2 G.

- 1) L'installazione di sistemi Ex deve essere eseguita esclusivamente da personale specializzato.
- 2) I FLT93 Flowswitch devono essere collegati a terra.
- 3) I morsetti per il collegamento e l'elettronica sono incorporati in una custodia a prova di esplosione („d“) con le seguenti note:
 - La sicurezza si ottiene grazie ai cosiddetti „interstizi sperimentali massimi“, attraverso i quali una eventuale accensione all'interno della custodia non può propagarsi all'esterno o raggiungere altre parti dell'impianto.
 - La scatola di collegamento Ex-d ha una filettatura 3/4“ e/o 1“ NPT per il montaggio di un passacavo omologato Ex-d secondo EN50018/EN60079-1.
 - Prima di aprire il coperchio della custodia „d“ (per es. durante operazioni di collegamento o di manutenzione) accertarsi che l'apparecchio sia disinserito o che non si trovi in presenza di atmosfere esplosive.
 - Avvitare il coperchio della custodia „d“ fino all'arresto. Per impedire lo svitamento del coperchio é possibile allentare una delle 2 viti esagonali poste sul corpo della custodia, incastrandola nella sagoma del coperchio.

NL**B****Nederlands - Veiligheidsinstructies**

Deze veiligheidsinstructies gelden voor de Fluid Components, FLT93 Flowswitch overeenkomstig de EG-typeverklaring nr. KEMA 02 ATEX 2166 (nummer van de verklaring op het typeplaatje) voor gebruik in een explosieve atmosfeer volgens Categorie II 2G.

- 1) Installatie van Ex-instrumenten dient altijd te geschieden door geschoold personeel.
- 2) De FLT93 moet geaard worden.
- 3) De aansluitklemmen en de electronika zijn ingebouwd in een drukvaste behuizing met de volgende opmerkingen:
 - De schroefdraadspleet tussen de behuizing en de deksel is een ontstekingsdoorslagveilige spleet.
 - De Ex-d aansluitbehuizing heeft een ¾” of een 1” NPT schroefdraad voor aansluiting van een volgens EN50018/EN60079-1 goedgekeurde Ex- 'd' kabelinvoer.
 - Er moet worden veilig gesteld dat vóór het openen bij een geopende deksel van de 'd' behuizing (bijv. bij aansluit- of service-werkzaamheden) hetzij de voedingsleiding spanningsvrij is, hetzij geen explosieve atmosfeer aanwezig is.
 - De deksel van de 'd' behuizing moet tijdens bedrijf tot aan de aanslag erin geschroefd zijn. Hij moet door het eruit draaien van een van de dekselborgschroeven worden geborgd.

P**Português - Normas de segurança**

Estas normas de segurança são válidas para os Fluid Components, FLT93 Flowswitch conforme o certificado de teste de modelo N.º KEMA 02 ATEX 2166 (número do certificado na plaqueta com os dados do equipamento)

são apropriados para utilização em atmosferas explosivas categoria II 2 G.

- 1) A instalação de equipamentos em zonas sujeitas a explosão deve, por princípio, ser executada por técnicos qualificados.
- 2) Os FLT93 Flowswitch precisam ser ligados à terra.
- 3) Os terminais e a electrónica para a conexão da tensão de alimentação estão instalados num envólucro com protecção contra ignição á prova de sobrepressão com as seguintes notas:
 - A fenda entre o envólucro e a tampa deve ser á prova de passagem de centelha.
 - O envólucro de conexão Ex-“d“ possui uma rosca 1“ NPT e/ou 3/4“ NPT para a entrada de cabos Ex-“d“ certificado conforme a norma EN50018/EN60079-1.
 - Deve-se assegurar que, antes de abrir a tampa do armário „d“ (por exemplo, ao efectuar a conexão ou durante trabalhos de manutenção), o cabo de alimentação esteja sem tensão ou que a atmosfera não seja explosiva.
 - Durante a operação, a tampa do envólucro „d“ deve estar aparafusada até o encosto. A tampa deve ser bloqueada, por um dos parafusos de fixação.

E**Español - Instrucciones de seguridad**

Estas indicaciones de seguridad son de aplicación para el modelo FLT93 Flowswitch de Fluid Components, según la certificación CE de modelo N° KEMA 02 ATEX 2166 para aplicaciones en atmósferas potencialmente explosivas según la categoría II 2 G (el número de certificación se indica sobre la placa informativa del equipo).

- 1) La instalación de equipos Ex tiene que ser realizada por personal especializado.
- 2) Los FLT93 Flowswitch tienen que ser conectados a tierra.
- 3) Los bornes de conexión y la unidad electrónica están montados dentro de una caja con protección antideflagrante y resistente a presión, considerándose los siguientes puntos:
 - La holgura entre la rosca de la tapa y la propia de la caja está diseñada a prueba contra ignición.
 - La caja tiene conexiones eléctricas para entrada de cables con rosca 3/4" y/o 1" NPT, donde deberán conectarse prensaestopas certificados Exd según EN50018/EN60079-1.
 - Antes de la apertura de la tapa de la caja "Exd" (p. ej. durante los trabajos de conexión o de puesta en marcha) hay que asegurar que el equipo se halle sin tensión o que no exista presencia de atmósfera explosiva.
 - Durante el funcionamiento normal: la tapa de la caja antideflagrante tiene que estar cerrada, roscada hasta el tope, debiéndose asegurar apretando los tornillos de bloqueo.

S**Svenska - Säkerhetsanvisningar**

Säkerhetsanvisningarna gäller för Fluid Components, Flödesmätare typ FLT93 Flowswitch enligt EG-typkontrollintyg nr KEMA 02 ATEX 2166 (intygsnumret återfinns på typskylten) är lämpad för användning i explosiv gasblandning i kategori II 2 G.

- 1) Installation av Ex- klassade instrument måste alltid utföras av fackpersonal.
- 2) FLT93 Flowswitch måste jordas.
- 3) Anslutningsklämmorna och elektroniken är inbyggda i en explosions och trycktät kapsling med följande kommentar:
 - Spalten mellan kapslingen och lockets gänga är flamsäker.
 - Ex-d kapslingen har en 3/4" och / eller 1" NPT gänga för montering av en EN50018/EN60079-1 typkontrollerad Ex- „d” kabel förskruvning
 - När Ex- „d”-kapslingens lock är öppet (t.ex. vid inkoppling - eller servicearbeten) ska man se till att enheten är spänningslös eller att ingen explosiv gasblandning förekommer. Under drift måste Ex - d”-kapslingens lock vara iskruvad till anslaget. För att säkra locket skruvarman i en av lockets insex låsskruvar.

APPENDIX D TEMPERATURE COMPENSATION

Introduction

Temperature compensation (Temp Comp) is an essential part of the FLT FlexSwitch circuitry. When the Temp Comp is set correctly, the instrument stays accurate over a process temperature range of 100°F. The instrument is a thermal dispersion device. It relies on the temperature differential between the reference RTD, which is at the process media temperature, and the active RTD, which is heated to produce a temperature differential (TD). For example; with constant temperature, flow rate, process media and heater power, the TD is reduced and reaches a stable value. If the process media temperature goes up and all other conditions stay the same, the TD is reduced. Without Temp Comp the circuitry would process the signal as an increased flow rate.

To understand Temp Comp the output signal needs to be understood first. This temperature output signal is the absolute voltage drop across the reference RTD, and proportional to temperature. The instrument uses this voltage for two purposes. The voltage drop across the reference RTD is subtracted from the voltage drop across the Active RTD to produce a voltage differential. The voltage differential is used to set flow or liquid level alarms. Also, the voltage drop across the reference RTD adds to, or subtracts from, the output signal as a function of TD.

Note: In order to adjust the Temp Comp correctly certain parameters must be measured and calculated. All temperature measurements should be converted to degrees Fahrenheit before a temperature differential is found. These parameters and measurements will be discussed later in this appendix.

Factory Temperature Compensation Settings

A Temp Comp adjustment procedure is performed on the instrument before it is shipped. Under normal conditions this setting will not have to be done by the customer. However, if there have been changes in environment since the instrument was ordered then the following instructions may need to be done by the customer.

Restoring Temp Comp Adjustments

When the control circuit is replaced or if the Temp Comp potentiometers are accidentally moved the adjustments must be restored. There are three adjustments that need to be made on the control circuit in order to set the Temp Comp. Two of the adjustments are done with no power applied to the instrument and a third adjustment is done with power applied. Calibration values for each instrument are on the Temp Comp calibration sheet that is found in the plastic page protector at the back of this manual. The calibration values are listed by the serial number of the instrument.

Equipment Required

- 5-1/2 digit digital multimeter (DMM). (Small clip leads are desirable.)
- Flat screw driver, capable of adjusting control circuit potentiometers.
- Temp Comp calibration values from the page protector in the back of this manual.
- Insulating varnish or equivalent to reseal the potentiometers.

Caution: The instrument contains electrostatic discharge (ESD) sensitive devices. Use standard ESD precautions when handling the control circuit. See Chapter 2, Installation, for ESD details.

Procedure

1. Turn off the instrument power. Remove the control circuit from the terminal board.
2. Write down where the heater wattage control jumper is located in the area of the upper left hand side of the control circuit (11 o'clock, P1 at top). Remove the heater wattage control jumper and place it on position J33. Refer to Figure 3-1 for the jumper location.
3. Remove jumpers J10 and J11 at the right side of the control circuit (2 o'clock) and set them aside.
4. Connect the DMM from TP1 (by J10), to the right jumper post of J10. Set the DMM to ohms. See Figure 3-2 for component placement.
5. Adjust potentiometer R5 (3 o'clock, next to the right thumbscrew) until the DMM reads the ohm value for R5 as shown on the Temp Comp calibration sheet that is in the plastic page protector in the back of this manual.
6. Remove the DMM, and reconnect it between TP2 (by J11), and the right jumper post of J11. Figure 3-1 shows jumper post location.
7. Adjust pot R8 (next to J10) until the ohm value for R8 is as shown on the Temp Comp Cal sheet.

- Remove the DMM and reinstall jumpers J10 and J11. Continue.

Balance Procedure

The following steps are the flow element balance procedure required to complete the Temp Comp restoration and must be used when installing remote units with more than 10 feet of cable.

- Connect the DMM to P1 with the positive lead connected to position 1 (Red) and the negative lead connected to position 2 (Blue). Re-install the control circuit on the Terminal Board. Set the DMM to volts DC. Place the heater jumper on J33.
- Turn on the instrument power and wait fifteen minutes for the instrument to stabilize. During this time make sure that the process media is flowing or the sensing elements are submerged. Do not make the following adjustment in still gas.
- Adjust potentiometer R13 (to the right of S1) until the DMM reads 0 volts $\pm 5\text{mV}$.
- Turn off the instrument power and remove the DMM. Re-install the heater jumper in its original position.

The Temp Comp adjustments are now restored. Turn on the power and make sure the instrument is functioning properly. Make adjustments to the alarm set points if needed.

Field Temp Comp Calibration

If the application of the instrument changes the Temp Comp may need to be re-calibrated. An example of when the Temp Comp needs to be re-calibrated is as follows: The process media is gas, the factory set Temp Comp is 40 to 140 °F. The instrument is then placed in an application that varies in temperature from 300 to 400 °F. In this case the instrument's accuracy would be greater with a new Temp Comp calibration performed.

Another example of where the accuracy will be affected and a Temp Comp calibration would need to be done is when the process media is changed, i.e. from water to heavy oil.

Temp Comp calibration is possible to do in the field if the test conditions are met and the data is measured correctly. However, in many applications it is difficult to achieve these parameters and it is easier to have the switch factory calibrated. To do the procedure the following parameters are required:

- The maximum temperature change does not exceed 100°F.
- The maximum temperature does not exceed the instruments rated maximum temperature.
- The velocity at which the switch will alarm needs to be known, and the same at both test temperatures.

Equipment Required

- | | |
|--------|---|
| 1 each | DC Power Supply, 0 to 20 Vdc minimum, at 0.5 Amps. |
| 2 each | 5-1/2 Digit DMM with 4 wire clip leads. |
| 1 each | #1 Flat blade screw driver. |
| 1 each | Flat screw driver, capable of adjusting control circuit potentiometers. |
| | Insulating varnish or equivalent to reseal the potentiometers. |

Procedure

- Turn off the instrument power.
- Install the instrument into the pipe or a test stand where it can be calibrated. Start the process media flowing at a normal rate. Cool the process media to the lowest temperature in the expected operating range.
- Remove the control circuit. Disconnect the element wires on terminal board, TB2A AND TB2B. *Note: These are spring terminals.*
- Connect the DMM's and the power supply to the sensing element as shown in Figure D-1.
- Set the power supply voltage to the proper voltage as shown in Table D-1. Turn on the power supply and check the voltage setting.
- Stop the process media flow and make sure that the media is at no flow and then let the instrument stabilize for fifteen minutes.
- Record the resistance values of the sensing elements and calculate the resistance differential (DR). If DR does not exceed the maximum DR of 280 ohms then proceed with the calibration. If the DR is above 280 ohms use the next lower heater wattage setting and let the instrument stabilize. Recheck the DR
- Start the process media flowing at the desired switch point velocity and at the low temperature, let the instrument stabilize for fifteen

minutes.

9. Record the resistance values of the active and reference RTD's at the low temperature.
10. Raise the temperature of the process media to the maximum expected temperature. With the instrument power on, let the instrument stabilize for fifteen minutes at the same set point velocity. The difference between the low and the high temperature should not exceed 100°F.
11. Record the resistance values of the active and reference RTD's for the high temperature.
12. Calculate the Temp Comp factor with the formula shown below.

$$\text{TEMP COMP FACTOR} = \frac{\Delta R \text{ Low Temperature} - \Delta R \text{ High Temperature}}{(R \text{ Reference High Temperature}) - (R \text{ Reference Low Temperature})}$$

The Temp Comp factor is not to exceed ±0.041.

13. If the Temp Comp factor is within tolerance, turn off the power to the instrument and stop the process media if needed. Disconnect the DMM's and the power supply from the instrument. Reconnect the sensing element wires to the control circuit socket and reinstall the socket in the enclosure if it was previously removed. Do not pinch the wires between the socket and the enclosure.
14. Look up the resistance values to adjust potentiometers R5 and R8 in the Temp Comp Factor table (Table D-2). Follow the procedure in the Restoring Temp Comp adjustment section using the values found in the table below.
15. If the calculated Temp Comp factor exceeds the allowable tolerance by a small amount (±0.01), using the maximum Temp Comp factor may make the instrument perform satisfactorily. However, if the factor is out of tolerance by more than ±0.01 then it will be necessary to repeat the calibration to verify the result. Continue with the adjustment procedure if the second result is within tolerance.

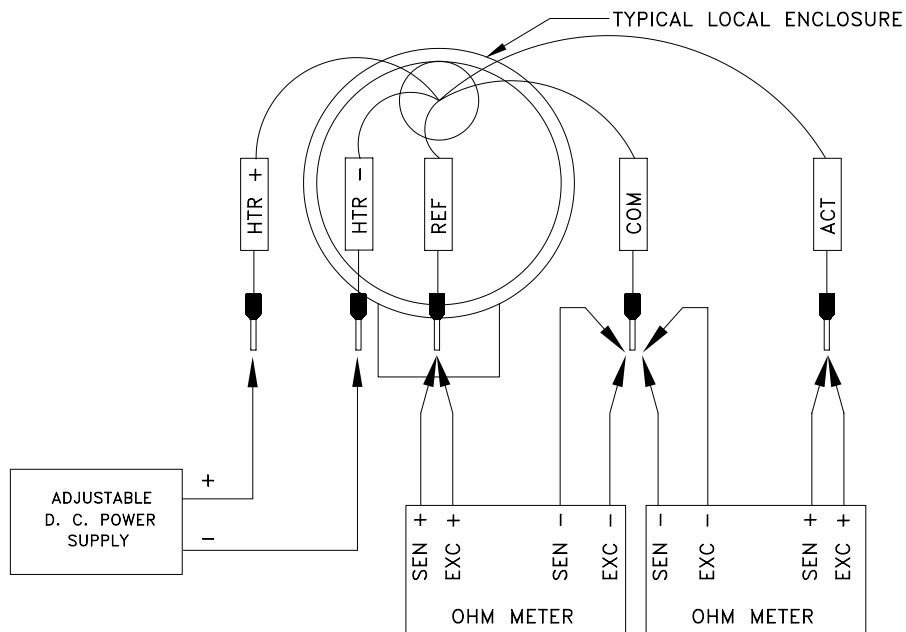

C00374-2-1

Figure D-1. Sensing Element Calibration Connections

POWER SUPPLY SETTINGS				
FLT93-S	3 Watts	1.75 Watts	0.75 Watts	0.21 Watts
	Set For 18.0 Vdc	Set For 13.8 Vdc	Set For 9.0 Vdc	Set For 4.9 Vdc
FLT93-F	0.57 Watts	0.52 Watts	0.40 Watts	0.25 Watts
	Set For 18.0 Vdc	Set For 17.0 Vdc	Set For 15.0 Vdc	Set For 11.8 Vdc

Table D-1. Heater Voltage Settings

TEMP COMP	R5	R8	TEMP COMP	R5	R8	TEMP COMP	R5	R8
FACTOR	K OHMS	K OHMS	FACTOR	K OHMS	K OHMS	FACTOR	K OHMS	K OHMS
0.042	119.75	263.16	0.013	123.38	149.25	-0.016	127.00	104.17
0.041	119.88	256.41	0.012	123.50	147.06	-0.017	127.13	103.09
0.04	120.00	250.00	0.011	123.63	144.93	-0.018	127.25	102.04
0.039	120.13	243.9	0.010	123.75	142.86	-0.019	127.38	101.01
0.038	120.25	238.10	0.009	123.88	140.85	-0.020	127.50	100.00
0.037	120.38	232.56	0.008	124.00	138.89	-0.021	127.63	99.01
0.036	120.5	227.27	0.007	124.13	136.99	-0.022	127.75	98.04
0.035	120.63	222.22	0.006	124.25	135.14	-0.023	127.88	97.09
0.034	120.75	217.39	0.005	124.38	133.33	-0.024	128.00	96.15
0.033	120.88	212.77	0.004	124.50	131.58	-0.025	128.13	95.24
0.032	121.00	208.33	0.003	124.63	129.87	-0.026	128.25	94.34
0.031	121.13	204.08	0.002	124.75	128.21	-0.027	128.38	93.46
0.030	121.25	200.00	0.001	124.88	126.58	-0.028	128.50	92.59
0.029	121.38	196.08	0.000	125.00	125.00	-0.029	128.63	91.74
0.028	121.5	192.31	-0.001	125.13	123.46	-0.030	128.75	90.91
0.027	121.63	188.68	-0.002	125.25	121.95	-0.031	128.88	90.09
0.026	121.75	185.19	-0.003	125.38	120.48	-0.032	129.00	89.29
0.025	121.88	181.82	-0.004	125.50	119.05	-0.033	129.13	88.50
0.024	122.00	178.57	-0.005	125.63	117.65	-0.034	129.25	87.72
0.023	122.13	175.44	-0.006	125.75	116.28	-0.035	129.38	86.96
0.022	122.25	172.41	-0.007	125.88	114.94	-0.036	129.50	86.21
0.021	122.38	169.49	-0.008	126.00	113.64	-0.037	129.63	85.47
0.020	122.5	166.67	-0.009	126.13	112.36	-0.038	129.75	84.75
0.019	122.63	163.93	-0.010	126.25	111.11	-0.039	129.88	84.03
0.018	122.75	161.29	-0.011	126.38	109.89	-0.040	130.00	83.33
0.017	122.88	158.73	-0.012	126.50	108.70	-0.041	130.13	82.64
0.016	123.00	156.25	-0.013	126.63	107.53	-0.042	130.25	81.97
0.015	123.13	153.85	-0.014	126.75	106.38			
0.014	123.25	151.52	-0.015	126.88	105.26			

Table D-2. Temp Comp Factor Table

APPENDIX E CUSTOMER SERVICE

Customer Service/ Technical Support

FCI provides full in-house technical support. Additional technical representation is also provided by FCI field representatives. Before contacting a field or in-house representative, please perform the troubleshooting techniques outlined in this document.

By Mail

Fluid Components International LLC
1755 La Costa Meadows Dr.
San Marcos, CA 92078-5115 USA
Attn: Customer Service Department

By Phone

Contact the area FCI regional representative. If a field representative is unable to be contacted or if a situation is unable to be resolved, contact the FCI Customer Service Department toll free at 1 (800) 854-1993.

By Fax

To describe problems in a graphical or pictorial manner, send a fax including a phone or fax number to the regional representative. Again, FCI is available by facsimile if all possibilities have been exhausted with the authorized factory representative. Our Fax number is 1 (760) 736-6250; it is available 7 days a week, 24 hours a day.

By E-Mail

FCI Customer Service can be contacted by e-mail at: techsupport@fluidcomponents.com. Describe the problem in detail making sure a telephone number and best time to be contacted is stated in the e-mail.

International Support

For product information or product support outside the contiguous United States, Alaska, or Hawaii, contact your country's FCI International Representative or the one nearest to you.

After Hours Support

For product information visit FCI at www.fluidcomponents.com. For product support call 1 (800) 854-1993 and follow the prerecorded instructions.

Point of Contact

The point of contact for service, or return of equipment to FCI is your authorized FCI sales/service office. To locate the office nearest you, please go to www.fluidcomponents.com.

Warranty Repairs or Returns

FCI prepays ground transportation charges for return of freight to the customer's door. FCI reserves the right to return equipment by the carrier of our choice.

International freight, handling charges, duty/entry fees for return of equipment are paid by the customer.

Non-Warranty Repairs or Returns

FCI returns repaired equipment to the customer either collect or prepaid and adds freight charges to the customer invoice.

Warranty

Extended warranty is available. Contact the factory.

Return to Stock Equipment

The customer is responsible for all shipping and freight charges for equipment that is returned to FCI stock from the customer site. These items will not be credited to the customer's account until all freight charges are cleared, along with applicable return to stock charges, from the credit invoice. (Exceptions are made for duplicate shipments made by FCI.)

If any repair or return equipment is received at FCI, freight collect, without prior factory consent, FCI bills the sender for these charges.

Field Service Procedures

Contact an FCI field representative to request field service.

A field service technician is dispatched to the site from either the FCI factory or one of the FCI representative offices. After the work is complete, the technician completes a preliminary field service report at the customer site and leaves a copy with the customer.

Following the service call, the technician completes a formal, detailed service report. The formal report is mailed to the customer after the technician's return to the factory or office.

Field Service Rates

All field service calls are billed at the prevailing rates as listed in the FCI Price Book unless previous arrangements have been made with the FCI Customer Service Manager.

Customers are charged for all travel expenses including airfare, auto rental, meals and lodging. In addition, the customer shall pay all costs of transporting parts, tools or goods to and from the job site. Invoicing travel time, field service work and other expenses will be performed by FCI's Accounting Department.



RA # _____

1755 La Costa Meadows Drive, San Marcos, CA 92078-5115 USA
760-744-6950 / 800-854-1993 / Fax: 760-736-6250
Web Site: www.fluidcomponents.com
E-mail: techsupport@fluidcomponents.com

Return Authorization Request

1. Return Customer Information

Returning Company's Name: _____ Phone# _____

Return Contact Name: _____ Fax # _____

Email Address: _____

2. Return Address

Bill To: _____ Ship To: _____

3. Mandatory End User Information

Contact: _____ Company: _____ Country: _____

4. Return Product Information

Model No: _____ Serial No(s): _____

Failure Symptoms (Detailed Description Required): _____

What Trouble Shooting Was Done Via Phone or Field Visit by FCI: _____

FCI Factory Technical Service Contact: _____

5. Reason For Return
- | | | | |
|---|---|---|---------------------------------|
| <input type="checkbox"/> Sensor Element | <input type="checkbox"/> Electronics | <input type="checkbox"/> As Found Testing | <input type="checkbox"/> Credit |
| <input type="checkbox"/> Recalibrate (New Data) | <input type="checkbox"/> Recalibrate (Most Recent Data) | <input type="checkbox"/> Other | |

(Note: A new Application Data Sheet (ADS) must be submitted for all recalibrations and re-certifications)

6. Payment Via
- | | | |
|---|--------------------------|--------------------------|
| <input type="checkbox"/> Faxed Purchase Order | <input type="checkbox"/> | <input type="checkbox"/> |
|---|--------------------------|--------------------------|

(Note: A priced quotation is provided for all Non-Warranty repairs after equipment has been evaluated. All Non-Warranty repairs are subject to a minimum evaluation charge of \$250.00)

Factory Return Shipping Address:	Fluid Components International LLC
	1755 La Costa Meadows Drive
	San Marcos, CA 92078-5115
	Attn: Repair Department
	RA # _____



The following Return Authorization Request form and Decontamination Statement **MUST be completed, signed and faxed back to FCI before** a Return Authorization Number will be issued. The signed Decontamination Statement and applicable MSDS Sheets **must be included with the shipment**. FCI will either fax, email or telephone you with the Return Authorization Number upon receipt of the signed forms.

Packing Procedures

1. **Electronics** should be wrapped in an **anti-static** or **static-resistant** bag, then wrapped in protective bubble wrap and surrounded with appropriate dunnage* in a box. Instruments weighing **more than 50 lbs., or extending more than four feet**, should be secured in wooden crates by bolting the assemblies in place.
2. **The sensor head must be protected** with pvc tubing, or retracted the full length of the probe, locked and secured into the Packing Gland Assembly (cap screws tightened down).
3. FCI can supply crates for a nominal fee.
4. No more than **four (4)** small units packaged in each carton.
5. **FCI will not be held liable for damage caused during shipping.**
6. To ensure immediate processing **mark** the RA number on the outside of the box. Items without an RA number marked on the box or crate may be delayed.
7. Freight **must be "PrePaid"** to FCI receiving door.

* Appropriate dunnage as defined by UPS, will protect package contents from a drop of 3 feet.

***** Decontamination Statement *** This Section Must Be Completed *****

Exposure to hazardous materials is regulated by Federal, State, County and City laws and regulations. These laws provide FCI's employees with the "Right to Know" the hazardous or toxic materials or substances in which they may come in contact while handling returned products. Consequently, FCI's employees must have access to data regarding the hazardous or toxic materials or substances the equipment has been exposed to while in a customer's possession. Prior to returning the instrument for evaluation/repair, FCI requires thorough compliance with these instructions. The signer of the Certificate must be either a knowledgeable Engineer, Safety Manager, Industrial Hygenist or of similar knowledge or training and responsible for the safe handling of the material to which the unit has been exposed. **Returns without a legitimate Certification of Decontamination, and/or MSDS when required, are unacceptable and shall be returned at the customer's expense and risk.** Properly executed Certifications of Decontamination must be provided before a repair authorization (RA) number will be issued.

Certification Of Decontamination

I certify that the returned item(s) has(have) been thoroughly and completely cleaned. If the returned item(s) has(have) been exposed to hazardous or toxic materials or substances, even though it (they) has (have) been thoroughly cleaned and decontaminated, the undersigned attests that the attached Material Data Safety Sheet(s) (MSDS) covers said materials or substances completely. Furthermore, I understand that this Certificate, and providing the MSDS, shall not waive our responsibility to provide a neutralized, decontaminated, and clean product for evaluation/repair at FCI. Cleanliness of a returned item or acceptability of the MSDS shall be at the sole discretion of FCI. **Any item returned which does not comply with this certification shall be returned to your location Freight Collect and at your risk.**

This certification must be signed by knowledgeable personnel responsible for maintaining or managing the safety program at your facility.

Process Flow Media _____

Product was or may have been exposed to the following substances: _____

Print Name _____

Authorized Signature _____ Date _____

Company Title _____

Visit FCI on the Worldwide Web: www.fluidcomponents.com

1755 La Costa Meadows Drive, San Marcos, California 92078-5115 USA † Phone: 760-744-6950 † 800-854-1993 † Fax: 760-736-6250

FCI Document No. 05CS00004D [U]

WARRANTIES

Goods furnished by the Seller are to be within the limits and of the sizes published by the Seller and subject to the Seller's standard tolerances for variations. All items made by the Seller are inspected before shipment, and should any of said items prove defective due to faults in manufacture or performance under Seller approved applications, or fail to meet the written specifications accepted by the Seller, they will be replaced or repaired by Seller at no charge to Buyer provided return or notice of rejection of such material is made within a reasonable period but in no event longer than three (3) years for non-calibration defects and one (1) year for calibration defects from date of shipment to Buyer, and provided further, that an examination by Seller discloses to Seller's reasonable satisfaction that the defect is covered by this warranty and that the Buyer has not returned the equipment in a damaged condition due to Buyer's or Buyer's employees', agents', or representatives' negligence and Buyer has not tampered, modified, redesigned, misapplied, abused, or misused the goods as to cause the goods to fail. In addition, this warranty shall not cover damage caused by Buyer's exposure of the goods to corrosive or abrasive environments. Moreover, Seller shall in no event be responsible for (1) the cost or repair of any work done by Buyer on material furnished hereunder (unless specifically authorized in writing in each instance by Seller), (2) the cost or repair of any modifications added by a Distributor or a third party, (3) any consequential or incidental damages, losses, or expenses in connection with or by reason of the use of or inability to use goods purchased for any purpose, and Seller's liability shall be specifically limited to free replacement, or refund of the purchase price, at Seller's option, provided return or rejection of the goods is made consistent with this paragraph, and the Seller shall in no event be liable for transportation, installation, adjustment, loss of good will or profits, or other expenses which may arise in connection with such returned goods, or (4) the design of products or their suitability for the purpose for which they are intended or used. Should the Buyer receive defective goods as defined by this paragraph, the Buyer shall notify the Seller immediately, stating full particulars in support of his claim, and should the Seller agree to a return of the goods, the Buyer shall follow Seller's packaging and transportation directions explicitly. In no case are the goods to be returned without first obtaining a return authorization from the Seller. Any repair or replacement shall be at Seller's factory, unless otherwise directed, and shall be returned to Seller transportation prepaid by Buyer. If the returned goods shall prove defective under this clause they will be replaced or repaired by Seller at no charge to Buyer provided the return or rejection of such material is made within a reasonable period, but in no event longer than (1) year from the date of shipment of the returned goods or the unexpired terms of the original warranty period whichever is later. If the goods prove to be defective under this paragraph, the Buyer shall remove the goods immediately from the process and prepare the goods for shipment to Seller. Continued use or operation of defective goods is not warranted by Seller and damage occurring due to continued use or operation shall be for Buyer's account. Any description of the goods contained in this offer is for the sole purpose of identifying them, and any such description is not part of the basis of the bargain, and does not constitute a warranty that the goods will conform to that description. The use of any sample or model in connection with this offer is for illustrative purposes only, is not part of the basis of the bargain, and is not to be construed as a warranty that the goods will conform to the sample or model. No affirmation of that fact or promise made by the Seller, whether or not in this offer, will constitute a warranty that the goods will conform to the affirmation or promise. THIS WARRANTY IS EXPRESSLY IN LIEU OF ANY AND ALL OTHER EXPRESS OR IMPLIED WARRANTIES WITH RESPECT TO THE GOODS OR THEIR INSTALLATION, USE, OPERATION, REPLACEMENT OR REPAIR, INCLUDING ANY IMPLIED WARRANTY OF MERCHANTABILITY OR FITNESS OF PURPOSE; AND THE GOODS ARE BEING PURCHASED BY BUYER "AS IS". SELLER WILL NOT BE LIABLE BY VIRTUE OF THIS WARRANTY OR OTHERWISE FOR ANY SPECIAL, INCIDENTAL OR CONSEQUENTIAL LOSS OR DAMAGE RESULTING FROM THE USE OR LOSS OF USE OF THE GOODS.



*Flow & Level Instrumentation
Solutions for Industrial Processes*

**FCI's Complete Customer Commitment. Worldwide
ISO 9001 and AS9100 Certified**

Visit FCI on the Worldwide Web: www.fluidcomponents.com

FCI World Headquarters

1755 La Costa Meadows Drive | San Marcos, California 92078 USA | Phone: 760-744-6950 Toll Free (US): 800-854-1993 Fax: 760-736-6250

FCI Europe

Persephonestraat 3-01 | 5047 TT Tilburg, The Netherlands | Phone: 31-13-5159989 Fax: 31-13-5799036

FCI Measurement and Control Technology (Beijing) Co., LTD | www.fluidcomponents.cn

Room 107, Xianfeng Building II, No.7 Kaituo Road, Shangdi IT Industry Base, Haidian District | Beijing 100085, P. R. China
Phone: 86-10-82782381 Fax: 86-10-58851152

Notice of Proprietary Rights

This document contains confidential technical data, including trade secrets and proprietary information which is the property of Fluid Components International LLC (FCI). Disclosure of this data to you is expressly conditioned upon your assent that its use is limited to use within your company only (and does not include manufacture or processing uses). Any other use is strictly prohibited without the prior written consent of FCI.

© Copyright 2013 by Fluid Components International LLC. All rights reserved.

Manufactured in accordance with one or more of the following patents: 5,600,528; 6,340,243. FCI is a registered trademark of Fluid Components International LLC. Information subject to change without notice.