

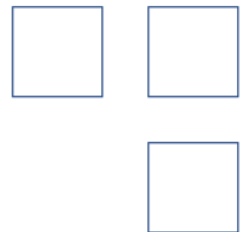

PROFIBUS PA Manual

MT100
Multipoint Flow Meter



Notice of Proprietary Rights

This document contains confidential technical data, including trade secrets and proprietary information which is the property of Fluid Components International LLC (FCI). Disclosure of this data to you is expressly conditioned upon your assent that its use is limited to use within your company only (and does not include manufacture or processing uses). Any other use is strictly prohibited without the prior written consent of FCI.

© Copyright 2017 by Fluid Components International LLC. All rights reserved. FCI is a registered trademark of Fluid Components International LLC. Information subject to change without notice.

Table of Contents

Introduction.....	1
Definition	1
Installation.....	2
General	2
Electrical Wiring.....	2
Topology and Network Configuration.....	2
Operation	3
Functional Description.....	3
Cyclic Operation Description.....	3
Cyclic Operation Setup.....	3
Acyclic Operation Description.....	4
System Blocks Description	5
Physical Block Parameters	5
Service Transducer Block Parameters.....	6
Transducer Blocks Description	7
Analog Input Blocks Description	9
Totalizer Blocks Description	12
Configuration	13
Setting the MT100 for PROFIBUS Operation	13
Configuring Process Parameters in the TB Modules.....	13
Configuring the MT100 AI Blocks.....	14
Configuring the Profile TOTALIZER Block	14
Using the MT100 PROFIBUS PA Service Transducer Block.....	15
Introduction to the Service Block	15
Basic Instrument Setup	16
Review of Instrument Min/Max Settings	16
Advanced Instrument Functions	16
General Station Description Files.....	16
GSD Files	16
Technical Characteristics.....	17
Appendix A - Codes and Tables.....	19
Appendix B - Customer Service/Technical Support	27

INTENTIONALLY LEFT BLANK

Introduction

This manual describes the MT100 PROFIBUS PA features, operation and configuration. The MT100 provides 3 different process variables that can drive an output: Flow, Temperature, and Flow Totalizer. The flow output can be selected as a volumetric flow, mass flow or velocity flow, depending on the MT100 configuration. The basic MT100 supports up to eight flow sensors and provides the average flow of all sensors in a single output.

The PROFIBUS variant used by the MT100 is PROFIBUS PA (Process Automation).

The MT100 is compliant with the PROFIBUS *Profile for Process Control Devices* specification Version 3.02. Profile: Multi-Variable Device.

The PROFIBUS PA is a master slave communication protocol. The MT100 with PROFIBUS PA has been configured as a multi-variable device. It implements both "Classical" and "Condensed" status and diagnostics. The MT100 PROFIBUS PA instrument also supports the Automatic Indent_Number adaptation feature.

The physical layer of the MT100 PROFIBUS PA instrument implements the H1 MBP (Manchester Bus Powered) interface that provides data and field bus power through the same cable and runs at a fixed speed of 31.25 kbits/sec.

PROFIBUS PA functionality is provided through an optional add-on card that plugs into the MT100's SB4 main board.

Definition

Physical Block: This block describes the necessary parameters and functions of the device or the device hardware itself.

Function Blocks: These blocks describe the functions of the device executing within the automation system. An example of a Function Block is the Analog Input (AI) block.

Transducer Block: This block contains the parameters of a device representing the necessary parameters and functions of the connection to the process. For example in the MT100 PROFIBUS PA the parameters are flow, temperature, and FCI Totalizer. The MT100 has two transducer blocks, Process TB and a Service TB. The Service TB is used for limited instrument configuration and some troubleshooting.

Analog Input (AI) Blocks: These blocks receive the MT100 Process Data Variables from the Process Data Transducer Block of the MT100 and make the process data of the MT100 available to other function blocks at the output.

There are three AI blocks in the MT100: Flow AI Block, Temperature AI Block, and Totalizer AI Block.

Totalizer Blocks: The TOTALIZER block integrates (accumulates) the rate (i.e. flow rate) to the corresponding integral. For example the MT100 offers two ways of providing the Totalize output of the Flow Rate; the FCI internally calculated "TOTALIZER," or the PA Totalizer Function Block. The user can choose one or the other. Only one can be used at a time.

GSD Files: The GSD file is an electronic device data sheet or device data base file that identifies the PROFIBUS device. All PROFIBUS devices (Class 1 masters and slaves) have their own GSD files.

FCI Configurator: A Windows-based application for accessing MT100 functions and features. The application is typically used for basic instrument setup and configuration, as well as provide access to advance functions. The FCI configurator interfaces through the MT100 USB service port or the Ethernet service port.

Installation

General

For details on the general mounting, placement of sensor head, and mounting options refer to the MT100 main manual **06EN003460**.

Electrical Wiring

Open the enclosure door to access the wiring terminal blocks. Use one of the cable ports at the bottom of the enclosure to route cable to the appropriate wiring connections. FCI recommends the use of PROFIBUS PA and FOUNDATION Fieldbus H1 cable compliant with the *H1 Cable Test Specification FF-844*.

The MT100 PROFIBUS PA connections are located near the bottom edge of the SB4 main board as shown in Figure 1 below. Connect the PROFIBUS PA cable to the J26 FB_A and FB_B terminals as labeled on board silkscreen. Loosen the J26 cable clamp #2-56 pan head phillips screws and thread the Fieldbus cable end through the clamp towards the connector. After making the wire connections, tighten the cable clamp screws to secure the cable to the board. Refer to the MT100 main manual **06EN003460** for further wiring details.

Note: PROFIBUS PA operation requires that the optional Fieldbus/PROFIBUS add-on card be installed onto the SB4 main board as shown in Figure 1 below. This card is installed at the factory when the MT100 is ordered with the Fieldbus/PROFIBUS option.

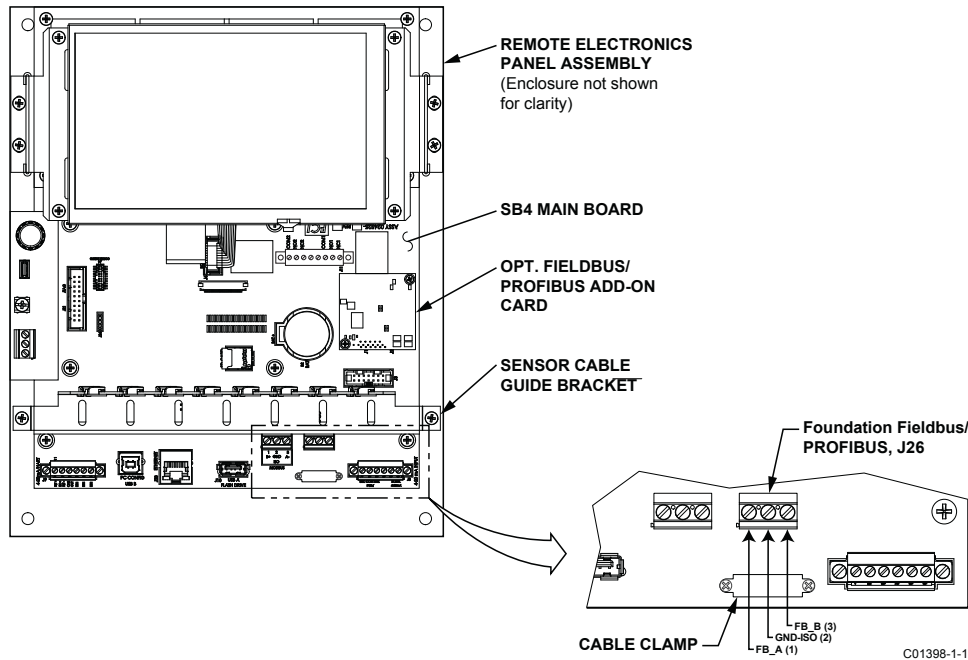

Figure 1 – MT100 Foundation Fieldbus Connections

Topology and Network Configuration

The MT100 supports both Bus topology and Tree topology. Both types have a trunk cable with two terminations. The devices are connected to the trunk via spurs. The spurs may be integrated in the device giving zero spur length. A spur may connect more than one device, depending on the length. Active couplers may be used to extend spur lengths.

Active repeaters may be used to extend the trunk length.

The total cable length, including spurs, between any two devices in the PROFIBUS network must not exceed 1900 m. Limit the connection of couplers to less than 15 per 250 m.

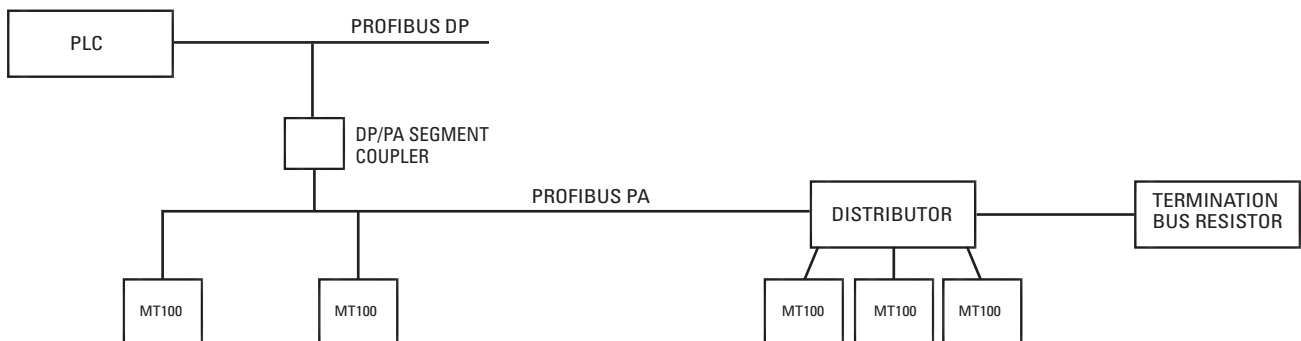

Operation

Functional Description

The MT100 is a flow meter with three flow classifications: volumetric flow, mass flow, and velocity flow. The MT100 also handles process temperature. The MT100 supports up to 8 flow sensors. The output is presented as an average of all the sensors in the system. The MT100 has the capability of viewing the output of an individual sensor.

Cyclic Operation Description

In the cyclic operation of the MT100 there are up to 3 possible output variables that are formatted as a value and status byte structure. The first 4 bytes are the value in a floating-point format, and the fifth and last byte is the status byte. The class-1 master, typically a PLC, handles cyclic data.

The MT100 is a PROFIBUS multi-variable device.

Flow	4 bytes (float)	1 byte	One of three flow types (Volumetric, Mass Flow, or Velocity).
Temperature	4 bytes (float)	1 byte	One type only.
Totalizer	4 bytes (float)	1 byte	One of two (FCI internal, or Profile Totalizer)
Reserved	4 bytes (float)	1 byte	A fourth output variable, Pressure, is not used by the MT100.

The MT100 supports both Classic and Condensed status byte formats as required by the PROFIBUS PA master.

Cyclic Operation Setup

In PROFIBUS all process data is presented through the DPV0 layer, so that a class-1 master can interpret it.

A typical process data configuration for the MT100 instrument is made up of process Flow data, process Temperature data, and Totalizer data. The Totalizer in this case is the MT100 native Totalizer. See example configuration screen below.

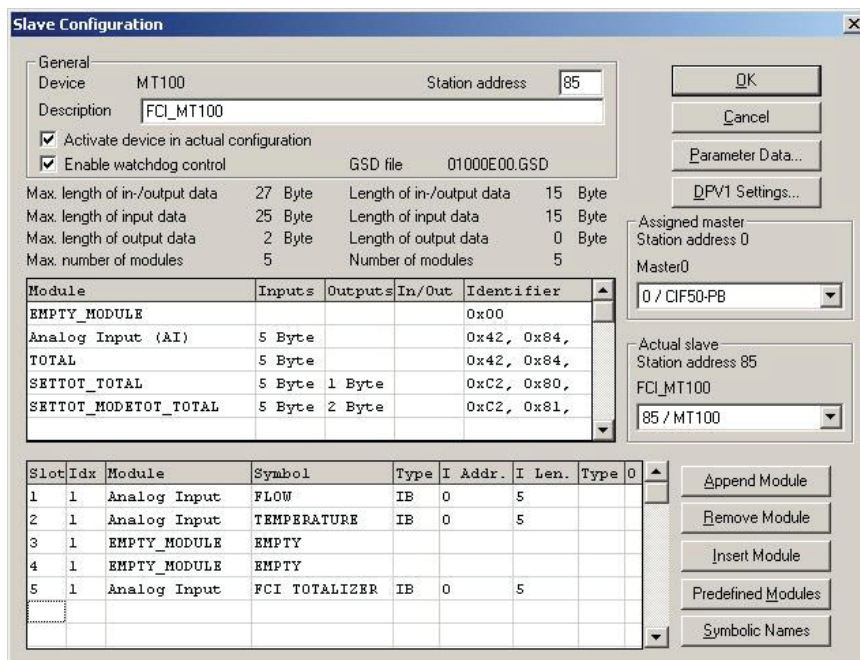

When configuring the MT100 it is very important to follow the Slot sequence described below. If a module is not needed make sure to load an "EMPTY MODULE" in its place. In the example above the two "EMPTY_MODULE" modules are taking the place of the PRESSURE AI (not applicable to MT100) and the profile TOTALIZER. The recommended TOTALIZER to use is the MT100 internal totalizer.

MT100 AI SLOT DEFINITION TABLE	
1	FLOW
2	TEMPERATURE
3	PRESSURE (N/A FOR MT100)
4	PROFILE TOTALIZER
5	FCI INT. TOTALIZER

Acyclic Operation Description

A number of transducer blocks that receive the process data from the instrument and a corresponding number of analog input blocks support the acyclic data operation of the MT100. See diagram below for an overview of the process.

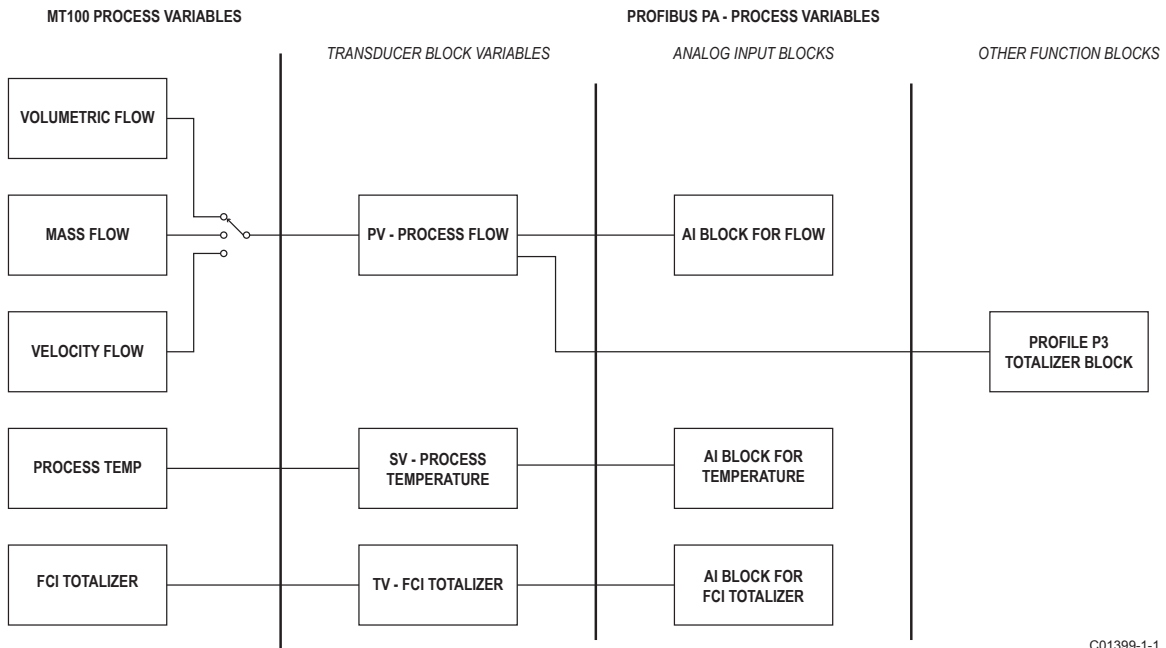

The MT100 implements the PROFIBUS PA Profile 3 for a multi-variable device. Profile 3 uses a function block model to organize the variables and the parameters. The diagram shows the PROFIBUS PA function blocks. A class 2 master is needed to access the profile 3 function blocks.

System Blocks Description**Physical Block Parameters**

This block contains general PROFIBUS PA instrument information. This information identifies the device in the network and its software and hardware version, as well as control some instrument level functions.

REL. INDEX	PARAMETER	SLOT	INDEX	DATA TYPE (LENGTH)	STORE	SIZE	READ/WRITE
8	SOFTWARE_REVISION	0	24	VISIBLESTRING	C	16	R
9	HARDWARE_REVISION	0	25	VISIBLESTRING	C	16	R
10	DEVICE_MAN_ID	0	26	UNSIGNED 16	C	2	R
11	DEVICE_ID	0	27	VISIBLESTRING	C	16	R
12	DEVICE_SER_NUM	0	28	VISIBLESTRING	C	16	R
13	DIAGNOSIS	0	29	OCTETSTRING	D	4	R
14	DIAGNOSIS_EXTENSION	0	30	OCTETSTRING	D	6	R
15	DIAGNOSIS_MASK	0	31	OCTETSTRING	C	4	R
16	DIAGNOSIS_MASK_EXTENSION	0	32	OCTETSTRING	C	6	R
17	DEVICE_CERTIFICATION	0	33	VISIBLESTRING	C	32	R
18	WRITE_LOCKING	0	34	UNSIGNED 16	N	2	RW
19	FACTORY_RESET	0	35	UNSIGNED 16	S	2	RW
20	DESCRIPTOR	0	36	OCTETSTRING	S	32	RW
21	DEVICE_MESSAGE	0	37	OCTETSTRING	S	32	RW
22	DEVICE_INSTAL_DATE	0	38	OCTETSTRING	S	16	RW
23	NOT USED	0	39				
24	IDENT_NUMBER_SELECTOR	0	40	UNSIGNED8	S	1	RW
25	HW_WRITE_PROTECTION	0	41	UNSIGNED8	D	1	R
26	FEATURE	0	42	DS-68	N	8	R
27	COND_STATUS_DIAG	0	43	UNSIGNED8	S	1	RW
28	DIAG_EVENT_SWITCH	0	44	DIAG_EVENT_SWITCH	S	50	RW
29-32	RESERVED BY PNO	0	45-48				

Service Transducer Block Parameters

The Service Transducer Block is a manufacturer-specific block that contains MT100 configuration and setup parameters so that some configuration can be done from the control room through PROFIBUS PA. It facilitates the changing of pipe size dimensions, restoring the current cal group to the original factory values. It also allows the user to change flow type (Volumetric, Mass Flow, and Velocity). This block also enables/disables the MT100 FCI TOTALIZER and allows viewing of individual sensor variables for troubleshooting purposes.

REL. INDEX	PARAMETER	SLOT	INDEX	DATA TYPE (LENGTH)	STORE	SIZE	READ/WRITE
8	FLOW_TYPE	10	24	UNSIGNED 8	D	1	RW
9	TOTALIZER_STATE	10	25	UNSIGNED 8	D	4	RW
10	PLENUM_SIZE_VALUE1	10	26	FLOAT	D	4	RW
11	PLENUM_SIZE_VALUE2	10	27	FLOAT	D	4	RW
12	WRITE_PROTECT_MODE	10	28	UNSIGNED 8	D	1	RW
13	FACTORY_RESTORE	10	29	UNSIGNED 8	D	1	RW
14	DEVICE_CO	10	30	OCTETSTRING	D	10	R
15	DEVICE_SERIAL_NUM	10	31	OCTETSTRING	D	10	R
16	DEVICE_SFTWR_VER	10	32	OCTETSTRING	D	4	R
17	SENSORS_BANK_1	10	33	FLOAT	D	48	R

Transducer Blocks Description

There are two Process Data Transducer blocks in the MT100, one for each process variable that the MT100 can measure: flow and temperature.

Flow Transducer Block Parameters

There are three possible flow types, but only one is active at a time. The active flow type is the only one that has valid data in that structure of the block.

REL. INDEX	PARAMETER	SLOT	INDEX	DATA TYPE (LENGTH)	STORE	SIZE	READ/WRITE
8	CALIBR_FACTOR	6	24	FLOAT	S	4	RW
9	LOW_FLOW_CUTOFF	6	25	FLOAT	S	4	RW
10	MEASUREMENT_MODE	6	26	UNSIGNED 8	S	1	RW
11	FLOW_DIRECTION	6	27	UNSIGNED 8	S	1	RW
12-14	NOT USED	6	28-30				
15	NOMINAL_SIZE	6	31	FLOAT	S	4	RW
16	NOMINAL_SIZE_UNITS	6	32	UNSIGNED 16	S	2	RW
17	VOLUME_FLOW	6	33	101(DS-33)	D	5	R
18	VOLUME_FLOW_UNITS	6	34	UNSIGNED 16	S	2	RW
19	VOLUME_FLOW_LO_LIMIT	6	35	FLOAT	S	4	R
20	VOLUME_FLOW_HI_LIMIT	6	36	FLOAT	S	4	R
21	MASS_FLOW	6	37	101(DS-33)	D	5	R
22	MASS_FLOW_UNITS	6	38	UNSIGNED 16	S	2	RW
23	MASS_FLOW_LO_LIMIT	6	39	FLOAT	S	4	R
24	MASS_FLOW_HI_LIMIT	6	40	FLOAT	S	4	R
25-42	NOT USED	6	41-58				
43-52	RESERVED BY PI	6	59-68				
53	VELOCITY_FLOW	6	69	101(DS-33)	D	5	R
54	VELOCITY_UNITS	6	70	UNSIGNED 16	S	2	RW
55	VELOCITY_LO_LIMIT	6	71	FLOAT	S	4	RW
56	VELOCITY_HI_LIMIT	6	72	FLOAT	S	4	RW
57	DEVICE_VARIABLE_CODE	6	73	UNSIGNED 8	D	1	R

The following parameters are in the block for compatibility with the profile for flow but perform no real function since the method of measurement used by the MT100 does not use those parameters. The parameters are CALIBR_FACTOR, LOW_FLOW_CUTOFF, MEASUREMENT_MODE, and FLOW_DIRECTION.

The NOMINAL_SIZE, and the NOMINAL_SIZE_UNITS parameters are used for Volume flow and the Mass flow. These parameters are associated with the pipe dimensions and units. NOMINAL_SIZE is the diameter of the pipe.

DEVICE_VARIABLE_CODE identifies the instrument's active flow type: Volumetric flow = 0, Mass flow = 3, or Velocity flow = 4.

Temperature Transducer Block Parameters

The MT100 uses RTDs to measure flow, with the reference RTD also measuring process temperature. This block provides the measured temperature.

REL. INDEX	PARAMETER	SLOT	INDEX	DATA TYPE (LENGTH)	STORE	SIZE	READ/WRITE
8	PRIMARY_VALUE	7	24	101(DS-33)	D	5	R
9	PRIMARY_VALUE_UNIT	7	25	UNSIGNED 16	S	2	RW
10	SECONDARY_VALUE_1	7	26	101(DS-33)	D	5	R
11	NOT USED	7	27				
12	SENSOR_MEAS_TYPE	7	28	UNSIGNED 8	S	1	RW
13	INPUT_RANGE	7	29	UNSIGNED 8	S	1	RW
14	LIN_TYPE	7	30	UNSIGNED 8	S	1	RW
15 - 18	NOT USED	7	31 - 34				
19	BIAS_1	7	35	FLOAT	S	4	RW
20	NOT USED	7	36				
21	UPPER_SENSOR_LIMIT	7	37	FLOAT	N	4	R
22	LOWER_SENSOR_LIMIT	7	38	FLOAT	N	4	R
23	NOT USED	7	39				
24	INPUT_FAULT_GEN	7	40	UNSIGNED 8	D	1	R
25	INPUT_FAULT_1	7	41	UNSIGNED8	D	1	R
26 - 32	NOT USED	7	42 - 48				
33 - 35	Reserved by PI	7	49 - 51				
36	SENSOR_CONNECTION	7	52	UNSIGNED8	S	1	RW
37	COMP_WIRE1	7	53	FLOAT	S	4	RW

FCI Internal Totalizer Transducer Block Parameters

The MT100 has a built-in totalizer function. This function is made available through the PROFIBUS PA protocol in addition to providing the PROFIBUS PA profile TOTALIZER. FCI recommends the use of the internal totalizer function for all totalizer applications.

REL. INDEX	PARAMETER	SLOT	INDEX	DATA TYPE (LENGTH)	STORE	SIZE	READ/WRITE
8	TOTALIZER_STATE	9	24	UNSIGNED 8	D	1	RW
9	TOTALIZER_VALUE	9	25	FLOAT	D	4	R
10	TOTALIZER_DYNAMIC_VALUE	9	26	101(DS33)	D	5	R
11	TOTALIZER_UNIT_CODE	9	27	UNSIGNED 8	D	1	R

Analog Input Blocks Description

There are 3 AI blocks: Flow, Temperature, and Totalizer.

The AI blocks are the ones that present the process variable data that gets mapped to the DPV0 PROFIBUS layer for the cyclic transmission to the PROFIBUS master.

Flow Analog Input (AI) Block

The Flow AI block is the instrument's primary output variable. This block gets its input from the Flow Transducer block.

REL. INDEX	PARAMETER	SLOT	INDEX	DATA TYPE (LENGTH)	STORE	SIZE	READ/WRITE
1	ST_REV	1	17	UNSIGNED16	N	2	R
2	TAG_DESC	1	18	OCTETSTRING	S	32	RW
3	STRATEGY	1	19	UNSIGNED16	S	2	RW
4	ALERT_KEY	1	20	UNSIGNED 8	S	1	RW
5	TARGET_MODE	1	21	UNSIGNED 8	S	1	RW
6	MODE_BLK	1	22	DS-37	S	3	R
7	ALARM_SUM	1	23	DS-42	D	8	R
8	BATCH	1	24	DS-67	S	10	RW
10	OUT (FLOW)	1	26	DS-33	D	5	R
11	PV_SCALE	1	27	FLOAT	S	8	R/W
12	OUT_SCALE	1	28	DS36	S	11	R/W
13	LIN_TYPE	1	29	UNSIGNED 8	S	1	R/W
14	CHANNEL	1	30	UNSIGNED16	S	2	R/W
16	PV_FTIME	1	32	FLOAT	S	4	R/W
17	FSAFE_TYPE	1	33	UNSIGNED 8	S	1	R/W
18	FSAFE_VALUE	1	34	FLOAT	S	4	R/W
19	ALARM_HYS	1	35	FLOAT	S	4	R/W
21	HI_HI_LIM	1	37	FLOAT	S	4	R/W
23	HI_LIM	1	39	FLOAT	S	4	R/W
25	LO_LIM	1	41	FLOAT	S	4	R/W
27	LO_LO_LIM	1	43	FLOAT	S	4	R/W
30	HI_HI_ALM	1	46	DS-39	D	16	R
31	HI_ALM	1	47	DS-39	D	16	R
32	LO_ALM	1	48	DS-39	D	16	R
33	LO_LO_ALM	1	49	DS-39	D	16	R
34	SIMULATE	1	50	DS50	S	6	R/W
35	OUT_UNIT_TEXT	1	51	OCTETSTRING	S	16	R/W

Temperature Analog Input (AI) Block

The Temperature AI block is the secondary parameter of the MT100 instrument. This block gets its input from the Temperature Transducer Block.

REL. INDEX	PARAMETER	SLOT	INDEX	DATA TYPE (LENGTH)	STORE	SIZE	READ/WRITE
1	ST_REV	2	17	UNSIGNED16	N	2	R
2	TAG_DESC	2	18	OCTETSTRING	S	32	RW
3	STRATEGY	2	19	UNSIGNED16	S	2	RW
4	ALERT_KEY	2	20	UNSIGNED 8	S	1	RW
5	TARGET_MODE	2	21	UNSIGNED 8	S	1	RW
6	MODE_BLK	2	22	DS-37	S	3	R
7	ALARM_SUM	2	23	DS-42	D	8	R
8	BATCH	2	24	DS-67	S	10	RW
10	OUT (TEMP.)	2	26	DS-33	D	5	R
11	PV_SCALE	2	27	FLOAT	S	8	R/W
12	OUT_SCALE	2	28	DS36	S	11	R/W
13	LIN_TYPE	2	29	UNSIGNED 8	S	1	R/W
14	CHANNEL	2	30	UNSIGNED16	S	2	R/W
16	PV_FTIME	2	32	FLOAT	S	4	R/W
17	FSAFE_TYPE	2	33	UNSIGNED 8	S	1	R/W
18	FSAFE_VALUE	2	34	FLOAT	S	4	R/W
19	ALARM_HYS	2	35	FLOAT	S	4	R/W
21	HI_HI_LIM	2	37	FLOAT	S	4	R/W
23	HI_LIM	2	39	FLOAT	S	4	R/W
25	LO_LIM	2	41	FLOAT	S	4	R/W
27	LO_LO_LIM	2	43	FLOAT	S	4	R/W
30	HI_HI_ALM	2	46	DS-39	D	16	R
31	HI_ALM	2	47	DS-39	D	16	R
32	LO_ALM	2	48	DS-39	D	16	R
33	LO_LO_ALM	2	49	DS-39	D	16	R
34	SIMULATE	2	50	DS50	S	6	R/W
35	OUT_UNIT_TEXT	2	51	OCTETSTRING	S	16	R/W

Totalizer Analog Input Block

This block takes the input data from the Process Data Transducer Block, selected by the "Totalizer Average Channel" and makes it available to other function blocks at its output.

REL. INDEX	PARAMETER	SLOT	INDEX	DATA TYPE (LENGTH)	STORE	SIZE	READ/WRITE
1	ST_REV	4	17	UNSIGNED16	N	2	R
2	TAG_DESC	4	18	OCTETSTRING	S	32	RW
3	STRATEGY	4	19	UNSIGNED16	S	2	RW
4	ALERT_KEY	4	20	UNSIGNED 8	S	1	RW
5	TARGET_MODE	4	21	UNSIGNED 8	S	1	RW
6	MODE_BLK	4	22	DS-37	S	3	R
7	ALARM_SUM	4	23	DS-42	D	8	R
8	BATCH	4	24	DS-67	S	10	RW
10	TOTAL	4	26	101	N	5	RW*
11	UNIT_TOT	4	27	UNSIGNED16	S	2	R/W
12	CHANNEL	4	28	UNSIGNED16	S	2	R/W
13	SET_TOT	4	29	UNSIGNED 8	N	1	R/W
14	MODE_TOT	4	30	UNSIGNED 8	N	1	R/W
15	FAIL_TOT	4	31	UNSIGNED 8	S	1	R/W
16	PRESET_TOT	4	32	FLOAT	S	4	R/W
17	ALARM_HYS	4	33	FLOAT	S	4	R/W
18	HI_HI_LIM	4	34	FLOAT	S	4	R/W
19	HI_LIM	4	35	FLOAT	S	4	R/W
20	LO_LIM	4	36	FLOAT	S	4	R/W
21	LO_LO_LIM	4	37	FLOAT	S	4	R/W
22	HI_HI_ALM	4	38	DS-39	D	16	R
23	HI_ALM	4	39	DS-39	D	16	R
24	LO_ALM	4	40	DS-39	D	16	R
25	LO_LO_ALM	4	41	DS-39	D	16	R

Totalizer Blocks Description

The MT100 PROFIBUS PA offers two ways of getting the totalized value of the flow for Volumetric and Mass flow. The FCI Internal TOTALIZER is computed internally by the MT100 system. The other TOTALIZER is computed by the PROFIBUS PA profile TOTALIZER module. The recommended TOTALIZER module to use is the FCI internal TOTALIZER.

FCI Internal Totalizer Block

MT100 instruments are typically shipped from the factory with the Totalizer functions turned off. When the TOTALIZER function is needed FCI recommends that the FCI Internal TOTALIZER function be used. Use the TOTALIZER Transducer Block to turn the TOTALIZER on.

REL. INDEX	PARAMETER	SLOT	INDEX	DATA TYPE (LENGTH)	STORE	SIZE	READ/WRITE
1	ST_REV	5	17	UNSIGNED16	N	2	R
2	TAG_DESC	5	18	OCTETSTRING	S	32	RW
3	STRATEGY	5	19	UNSIGNED16	S	2	RW
4	ALERT_KEY	5	20	UNSIGNED 8	S	1	RW
5	TARGET_MODE	5	21	UNSIGNED 8	S	1	RW
6	MODE_BLK	5	22	DS-37	S	3	R
7	ALARM_SUM	5	23	DS-42	D	8	R
8	BATCH	5	24	DS-67	S	10	RW
10	OUT (TOT FCI)	5	26	DS-33	D	5	R
11	PV_SCALE	5	27	FLOAT	S	8	R/W
12	OUT_SCALE	5	28	DS36	S	11	R/W
13	LIN_TYPE	5	29	UNSIGNED 8	S	1	R/W
14	CHANNEL	5	30	UNSIGNED16	S	2	R/W
16	PV_FTIME	5	32	FLOAT	S	4	R/W
17	FSAFE_TYPE	5	33	UNSIGNED 8	S	1	R/W
18	FSAFE_VALUE	5	34	FLOAT	S	4	R/W
19	ALARM_HYS	5	35	FLOAT	S	4	R/W
21	HI_HI_LIM	5	37	FLOAT	S	4	R/W
23	HI_LIM	5	39	FLOAT	S	4	R/W
25	LO_LIM	5	41	FLOAT	S	4	R/W
27	LO_LO_LIM	5	43	FLOAT	S	4	R/W
30	HI_HI_ALM	5	46	DS-39	D	16	R
31	HI_ALM	5	47	DS-39	D	16	R
32	LO_ALM	5	48	DS-39	D	16	R
33	LO_LO_ALM	5	49	DS-39	D	16	R
34	SIMULATE	5	50	DS50	S	6	R/W
35	OUT_UNIT_TEXT	5	51	OCTETSTRING	S	16	R/W

PROFIBUS PA Profile Totalizer Block

This function implements the PROFIBUS PA Profile specified TOTALIZER function. For additional information refer to the PROFIBUS PA standard.

Configuration

For details on the general mounting, placement of sensor head, and mounting options see the MT100 main manual **06EN003460**.

Setting the MT100 for PROFIBUS Operation

Note: If the MT100 was ordered from the factory as a PROFIBUS device, the factory will have configured the instrument accordingly with no further instrument configuration required.

The MT100 PC configurator is used to select the communication protocol.

Connect the PC with the configurator software to the MT100 USB port using FCI's USB cable (P/N 026003-01).

To configure the MT100 for PROFIBUS launch the MT100 Configurator (with the system already running and connected to the PC). Select *Configuration* branch from the menu tree on the window's left side, observe that **Output** tab is selected. In the window's *Digital Output Selection* field, click the *Digital Bus* pull-down menu and select **FF/Profibus**. Then click **Send to Device** to program the MT100 (enter "2772" user password). Refer to the MT100 Configuration Software manual **06EN003461** details on digital bus configuration.

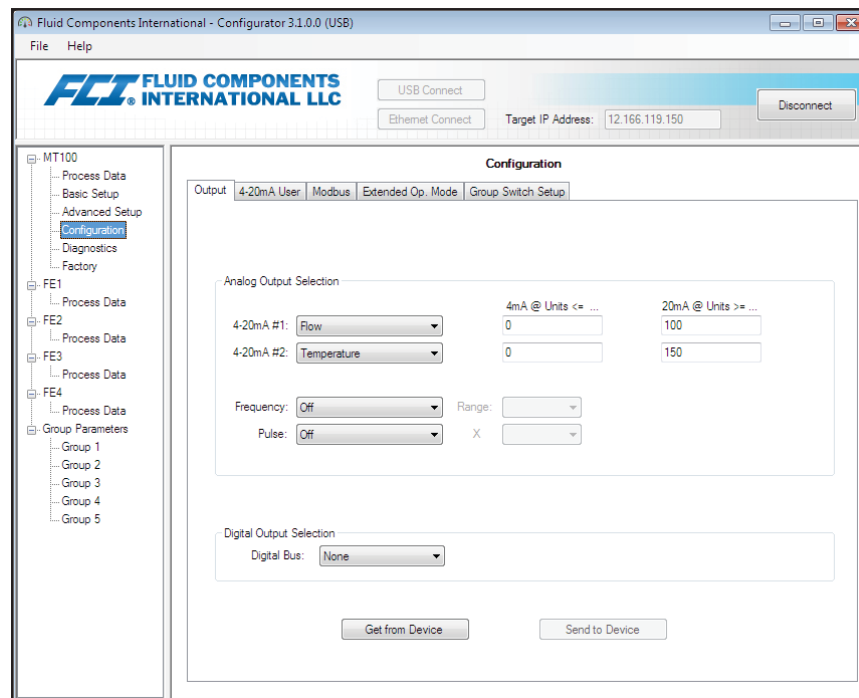

Configuring Process Parameters in the TB Modules

The "Flow Transducer TB" and the "Totalizer (FCI) TB" have a number of process related parameters that can be set within them. These parameters include *pipe size* under the NOMINAL_SIZE parameter; three flow engineering unit types, and the ability start and stop the MT100 internal FCI TOTALIZER.

Pipe Settings: Enter the pipe diameter value using the NOMINAL_SIZE (slot 6, index 31) parameter in the "Flow TB". Enter pipe size engineering units using the NOMINAL_SIZE_UNITS (slot 6, index 32) parameter.

Flow Units Settings: There are 3 possible flow types (Volumetric, Mass, and Velocity) and each has its own engineering units parameter. Only one flow type is active at a time. For volumetric units use VOLUME_FLOW_UNITS, for mass flow units use MASS_FLOW_UNITS, and for velocity flow use VELOCITY_UNITS.

TOTALIZER Start or Stop: To start the internal FCI TOTALIZER load a value of 1 into the TOTALIZER_STATE parameter. To stop the internal FCI TOTALIZER load a value of 0 into the TOTALIZER_STATE parameter.

Configuring the MT100 AI Blocks

The AI blocks make the process variables available to the cyclic DPV0 layer of the PROFIBUS protocol. AI blocks are used to configure and set the way that the process data is presented. Each AI block is preset to the designated Transducer Block channel, and the default prescribed by the profile. AI blocks are also used to set process alarms. The AI block configurable parameters are identified by a R/W definition in the AI block table's Read/Write column.

Note: Some of the settable parameters require putting the AI block in an "Out of Service" mode. To set the AI block in the OOS (Out of Service) mode load the value of 0x80 into the TARGET_MODE parameter. To set the AI block to the AUTO mode load the value of 0x08 into the TARGET_MODE parameter.

Configuring the Profile TOTALIZER Block

When using the Profile TOTALIZER block confirm that the instrument flow is in volumetric or mass flow. Listed below are the 4 parameters that can be used to manipulate the operation of the Profile TOTALIZER.

SET_TOT: Value 0x00: Sets the Profile TOTALIZER block into the "normal" TOTALIZE mode.
Value 0x01: Resets the TOTALIZER.
Value 0x02: Presets the block.

MODE_TOT: This parameter controls the behavior of the totalization.
Value 0x00: BALANCED behavior.
Value 0x01: POS_ONLY totalization.
Value 0x02: NEG_ONLY totalization.
Value 0x03: HOLD or stop behavior.

FAIL_TOT: This parameter sets the fail-safe mode.
Value 0x0: RUN - continue totalizing even if the input channel has a BAD status.
Value 0x1: HOLD - Totalization stops when the input channel has a BAD status.
Value 0x2: MEMORY - continue totalizing using last GOOD value when status is BAD.

PRESET_TOT: This parameter holds the value of the preset to be used by the PRESET mode.

Using the MT100 PROFIBUS PA Service Transducer Block**Introduction to the Service Block**

The MT100 Service Block provides access to a number of instrument configuration parameters and troubleshooting information. The multipoint configuration mode provides process information from each individual sensor and sensor electronics. Refer to the Service Transducers Block Parameters table on page 6.

Configuration Parameters:

FLOW_TYPE:	This parameter sets the instrument to one of three flow types: Velocity Flow = 0x04 Mass Flow = 0x03 Volumetric Flow = 0x00
TOTALIZER_STATE:	This parameter turns the FCI internal TOTALIZER ON or OFF: TOTALIZER ON = 0x01 TOTALIZER OFF = 0x00
PLENUM_SIZE_VALUE1:	For duct applications only: Enter duct width value for this parameter.
PLENUM_SIZE_VALUE2:	For duct applications only: Enter duct height value for this parameter.
WRITE_PROTECT_MODE:	This parameter inhibits ports (USB or Ethernet) other than PROFIBUS PA from accessing the setup parameters. Inhibit USB/Ethernet Port Access = 0x01 Do Not Inhibit USB/Ethernet Port Access = 0x00
FACTORY_RESTORE:	This parameter restores original factory-set calibration values to the current calibration group: Factory Restore = 0x01

Information Parameters:

DEVICE_CO:	This read-only parameter presents the Customer Order number assigned to the instrument.
DEVICE_SERIAL_NUM:	This read-only parameter presents the instrument's serial number.
DEVICE_SFTWR_VER:	This read-only parameter presents the instrument's software version.

Troubleshooting Parameters:

SENSORS_BANK_1:	This parameter allows viewing of individual sensor process data before averaging, giving technical personnel the means to identify sensor issues. Refer also to "Advanced Instrument Functions" on page 16.
-----------------	---

Basic Instrument Setup

The MT100 PROFIBUS PA comes with two GSD files, the profile version (pa139760.gsd) and the manufacturer specific file (01000E00.GSD). It is recommended that the FCI manufacturer-specific file be used. This file gives the user access to the maximum number of process variables the MT100 instrument has to offer.

To set the PROFIBUS PA address; a class 1 master or a class 2 master is required. The function of either the class 1 or class 2 master may be used to set the address.

For basic system configuration, the AI blocks are preset to their specific variable channels. Other parameters in the AI block are set to defaults.

Review of Instrument Min/Max Settings

The Flow Calibrated range is delimited by the MIN and MAX values set by the factory. Flow values outside of the range are not guaranteed to meet the accuracy specification. These parameters are read only, and can not be changed by the user.

Advanced Instrument Functions

For the MT100 the SENSORS_BANK_1 parameter can be used to view process data from individual sensor elements. SENSORS_BANK_1 supports the first 4 sensor parameters; the information is presented as floating values. The structure repeats for each bank. Only bank 1 is active.

Note: For an 8-sensor MT100 with the SB8 board, the SENSORS_BANK_1 parameter provides partial coverage by presenting process data for sensors 1-4 only. Sensors 5-8 are not covered.

Flow Value Sensor #1	Temperature Value Sensor #1
Flow Value Sensor #2	Temperature Value Sensor #2
Flow Value Sensor #3	Temperature Value Sensor #3
Flow Value Sensor #4	Temperature Value Sensor #4

General Station Description Files

GSD Files

The GSD files describe the communication features of the device, they also allow easy configuration of PROFIBUS networks with devices from different manufacturers. The GSD files can be thought as "driver" files for the device.

There are two GSD files provided in the accompanying PROFIBUS package. The first is the Profile 3 specific file created by the PNO; which is the International PROFIBUS Organization, and all profile compliant instrument must meet. The second file is a FCI-specific GSD file. This file supports features that are unique to the MT100 flow meter.

The GSD files contain the definitions of faults, and the type of process parameters available for display.

The PROFIBUS GSD Files for the MT100 are the following:

Profile Specific File: pa139760.gsd

FCI Specific File: 01000E00.gsd

Technical Characteristics

Physical Characteristics (PROFIBUS PA Channel)

- Permitted supply voltage: 9 to 32 V
- Current Consumption: 10 mA
- Data transmission rate: 31.25 kBaud
- Bus connection: Non-polarized
- Signal coding: MBP (Manchester coded Bus Powered)
- PROFIBUS PA in accordance with IEC 61158 (MBP), galvanically isolated

Profile 3 Characteristics

- PROFIBUS PA Version 3.02
- Instrument profile: Multi-Variable Device (Flow and Temperature)
- Function Blocks:

- 1 Physical Block
- 4 Transducer Blocks
 - Flow Transducer Block
 - Temperature Transducer Block
 - Totalizer (FCI Internal) Transducer Block
 - Service Transducer Block
- 3 AI (Analog Input) Blocks
 - Flow AI Block
 - Temperature AI Block
 - Totalizer (FCI Internal) AI Block
- 1 TOTALIZER Block (Profile)

INTENTIONALLY LEFT BLANK

Appendix A – Codes and Tables**MT100 ENGINEERING UNIT CODES TABLE**

<i>Description</i>	<i>PROFIBUS PA Codes</i>
TEMPERATURE UNIT CODES	
Degrees Celsius	1001
Degrees Fahrenheit	1002
VOLUMETRIC FLOW UNIT CODES	
SCFS (Standard Cubic Feet per Second)	1604
SCFM (Standard Cubic Feet per Minute)	1360
SCFH (Standard Cubic Feet per Hour)	1361
SCFD (Standard Cubic Feet per Day)	1605
NCMS (Normal Cubic Meters per Second)	1588
NCMM (Normal Cubic Meters per Minute)	1589
NCMH (Normal Cubic Meters per Hour)	1590
NCMD (Normal Cubic Meters per Day)	1591
NLPS (Normal Liters per Second)	1592
NLPM (Normal Liters per Minute)	1593
NLPH (Normal Liters per Hour)	1594
NLPD (Normal Liters per Day)	1595
MASS FLOW UNIT CODES	
LBPS (Pounds per Second)	1330
LBPM (Pounds per Minute)	1331
LBPH (Pounds per Hour)	1332
LBDP (Pounds per Day)	1333
KGPS (Kilograms per Second)	1322
KGPM (Kilograms per Minute)	1323
KGPH (Kilograms per Hour)	1324
KGPD (Kilograms per Day)	1325
TNPS (Metric Tonnes Per Second)	1326
TNPM (Metric Tonnes Per Minute)	1327
TNPH (Metric Tonnes Per Hour)	1328
TNPD (Metric Tonnes Per Day)	1329

MT100 ENGINEERING UNIT CODES TABLE (continued)

<i>Description</i>	<i>PROFIBUS PA Codes</i>
VELOCITY FLOW UNIT CODES	
SFPS (Standard Feet per Second)	1532
SFPM (Standard Feet per Minute)	1533
SFPH (Standard Feet per Hour)	1534
SFPD (Standard Feet per Day)	1535
NMPS (Normal Meters per Second)	1536
NMPM (Normal Meters per Minute)	1537
NMPH (Normal Meters per Hour)	1538
NMPD (Normal Meters per Day)	1539
TOTALIZER UNIT CODES	
SCF (Standard Cubic Feet)	1053
NCM (Normal Cubic Meters)	1573
NL (Normal Liters)	1574
LB (Pounds)	1094
KG (Kilograms)	1088
TN (Metric Tonnes)	1092
PLENUM (NOMINAL SIZE) UNIT CODES	
In (Inches)	1019
mm (Millimeters)	1013

MT100 PROFIBUS PA (CLASSIC) DIAGNOSIS TABLE

PROFIBUS PA DIAG_EXT	PROFIBUS PA Classic DIAG (*2)	MT100 FCI Error or Status Description	FCI Fault Type Fatal (F) or Non-Fatal (NF)
# 0-0	DA_HW_ELECTR	CORE: If any of these errors occur: I2C error, UART error, Mutex error, watchdog reset	F
# 0-1	—	FCI Reserved (Not Used)	—
# 0-2	—	FCI Reserved (Not Used)	—
# 0-3	DA_HW_ELECTR	CORE unable to update process data (PD_NO_FE_DATA). Unable to obtain/use data from any Active FEs	F
# 0-4	—	FCI Reserved (Not Used)	—
# 0-5	DA_HW_ELECTR	CORE detects FRAM/SPI error	F
# 0-6	DIA_MAINTENANCE	CORE reports SD card error. Either initialization (corrupt card) error, or card became full (error while writing)	NF
# 0-7	—	FCI Reserved (Not Used)	—

MT100 PROFIBUS PA (CLASSIC) DIAGNOSIS TABLE (continued)

PROFIBUS PA DIAG_EXT	PROFIBUS PA Classic DIAG (*2)	MT100 FCI Error or Status Description	FCI Fault Type Fatal (F) or Non-Fatal (NF)
# 1-0	—	FCI Reserved (Not Used)	—
# 1-1	—	FCI Reserved (Not Used)	—
# 1-2	—	FCI Reserved (Not Used)	—
# 1-3	—	FCI Reserved (Not Used)	—
# 1-4	—	FCI Reserved (Not Used)	—
# 1-5	DIA_HW_ELECTR	CORE: Unable to communicate with one or more FEs (PD_COMM_ERROR)	F
# 1-6	—	FCI Reserved (Not Used)	—
# 1-7	DIA_MEASUREMENT	CORE: Averaged flow out of range of "Flow Min" or "Flow Max"	NF
# 2-0	—	FCI Reserved (Not Used)	—
# 2-1	—	FCI Reserved (Not Used)	—
# 2-2	—	FCI Reserved (Not Used)	—
# 2-3	DIA_MEASUREMENT	CORE: Averaged temperature above "Temperature Max"	F
# 2-4	DIA_MEASUREMENT	CORE: Averaged temperature below "Temperature Min"	F
# 2-5	DIA_MEASUREMENT	(Any) FE reports SENSOR_HEATER_1_SHORTED_FAULT	F
# 2-6	DIA_MEASUREMENT	(Any) FE reports SENSOR_HEATER_2_SHORTED_FAULT	F
# 2-7	DIA_MEASUREMENT	(Any) FE reports SENSOR_HEATER_1_OPEN_FAULT	F
# 3-0	DIA_MEASUREMENT	(Any) FE reports SENSOR_HEATER_2_OPEN_FAULT	F
# 3-1	DIA_MEASUREMENT	(Any) FE reports SENSOR_ABOVE_MAX_A_D_FAULT	NF
# 3-2	DIA_MEASUREMENT	(Any) FE reports SENSOR_BELOW_MIN_A_D_FAULT	NF
# 3-3	—	FCI Reserved (Not Used)	—
# 3-4	DIA_MEASUREMENT	(Any) FE reports SENSOR_ABOVE_MAX_FLOW_FAULT	NF

MT100 PROFIBUS PA (CLASSIC) DIAGNOSIS TABLE (continued)

PROFIBUS PA DIAG_EXT	PROFIBUS PA Classic DIAG (*2)	MT100 FCI Error or Status Description	FCI Fault Type Fatal (F) or Non-Fatal (NF)
# 3-5	DIA_MEASUREMENT	(Any) FE reports ABOVE_dR_MAX_FAULT	NF
# 3-6	—	FCI Reserved (Not Used)	—
# 3-7	DIA_TEMP_ELECTR	(Any) FE reports TMP100_ADC_FAULT	NF
# 4-0	DIA_HW_ELECTR	(Any) FE reports AD5754_DAC_FAULT	F
# 4-1	—	FCI Reserved (Not Used)	—
# 4-2	DIA_HW_ELECTR	(Any) FE reports CURR_SENSORS_ADC_FAULT	NF
# 4-3	DIA_HW_ELECTR	(Any) FE reports HTRS_PRESSNS_ADC_FAULT	NF
# 4-4	DIA_MEASUREMENT	(Any) FE reports HTRS_FAULTS_ADC_FAULT	F
# 4-5	DIA_HW_ELECTR	(Any) FE reports FE_ARM7_UNDEFINE_FAULT	NF
# 4-6	DIA_HW_ELECTR	(Any) FE reports FE_ARM7_SWI_FAULT	NF
# 4-7	DIA_HW_ELECTR	(Any) FE reports FE_ARM7_PREFETCH_ABORT_FAULT	NF
# 5-0	DIA_HW_ELECTR	(Any) FE reports FE_ARM7_DATA_ABORT_FAULT	NF
# 5-1	DIA_HW_ELECTR	(Any) FE reports FE_ARM7_FIQ_FAULT	NF
# 5-2	DIA_HW_ELECTR	(Any) FE reports FE_ARM7_SPURIOUS_INT_FAULT	NF
# 5-3	—	FCI Reserved (Not Used)	—
# 5-4	—	FCI Reserved (Not Used)	—
# 5-5	—	FCI Reserved (Not Used)	—
# 5-6	—	FCI Reserved (Not Used)	—
# 5-7	—	FCI Reserved (Not Used)	—

CLASSIC DIAGNOSIS DEFINITIONS

<i>Classic DIAGNOSIS Mnemonic</i>	<i>Description</i>
DIA_HW_ELECTR	Hardware failure of the electronic
DIA_HW_MECH	Hardware failure mechanics
DIA_TEMP_MOTOR	Motor- temperature too high
DIA_TEMP_ELECTR	Electronic temperature too high
DIA_MEM_CHKSUM	Memory error
DIA_MEASUREMENT	Failure in measurement
DIA_NOT_INIT	Device not initialized (No self calibration)
DIA_INIT_ERR	Self calibration failed
DIA_ZERO_ERR	Zero point error (limit position)
DIA_SUPPLY	Power supply failed (electrical, pneumatic)
DIA_CONF_INVALID	Configuration not valid
DIA_MAINTENANCE	Maintenance required
DIA_CHARACTER	Characterization invalid

MT100 PROFIBUS PA (CONDENSED) DIAGNOSIS TABLE

PROFIBUS PA DIAG_EXT	PROFIBUS PA Condensed DIAG	FCI Fault Type Fatal (F) or Non-Fatal (NF)	PROFIBUS PA Status
# 0.0	DIA_MAINTENANCE_ALARM	F	BAD (4): ALL
# 0-1	FCI Reserved (Not Used)	—	—
# 0-2	FCI Reserved (Not Used)	—	—
# 0-3	DIA_MAINTENANCE_ALARM	F	BAD (4): ALL
# 0-4	FCI Reserved (Not Used)	—	—
# 0-5	DIA_MAINTENANCE_ALARM	F	BAD (4): ALL
# 0-6	DIA_MAINTENANCE	NF	GOOD (1): ALL
# 0-7	FCI Reserved (Not Used)	—	—
# 1-0	FCI Reserved (Not Used)	—	—
# 1-1	FCI Reserved (Not Used)	—	—
# 1-2	FCI Reserved (Not Used)	—	—
# 1-3	FCI Reserved (Not Used)	—	—
# 1-4	FCI Reserved (Not Used)	—	—
# 1-5	DIA_MAINTENANCE_ALARM	F	BAD (4): ALL
# 1-6	FCI Reserved (Not Used)	—	—
# 1-7	DIA_INV_PRO_COND		UNCERTAIN (5) 0, 2, 4

MT100 PROFIBUS PA (CONDENSED) DIAGNOSIS TABLE (continued)

PROFIBUS PA DIAG_EXT	PROFIBUS PA Condensed DIAG	FCI Fault Type Fatal (F) or Non-Fatal (NF)	PROFIBUS PA Status
# 2-0	FCI Reserved (Not Used)	—	—
# 2-1	FCI Reserved (Not Used)	—	—
# 2-2	FCI Reserved (Not Used)	—	—
# 2-3	DIA_INV_PRO_COND	F	BAD (6) 0,1,2,3,4,5
# 2-4	DIA_INV_PRO_COND	F	BAD (6) 0,1,2,3,4,5
# 2-5	DIA_MAINTENANCE_ALARM	F	BAD (4) 0,2,4
# 2-6	DIA_MAINTENANCE_ALARM	F	BAD (4) 0,2,4
# 2-7	DIA_MAINTENANCE_ALARM	F	BAD (4) 0,2,4
# 3-0	DIA_MAINTENANCE_ALARM	F	BAD (4) 0,2,4
# 3-1	DIA_INV_PRO_COND	NF	UNCERTAIN (5) 0,2,4
# 3-2	DIA_INV_PRO_COND	NF	UNCERTAIN (5) 0,2,4
# 3-3	FCI Reserved (Not Used)	—	—
# 3-4	DIA_INV_PRO_COND	NF	UNCERTAIN (5) 0,2,4
# 3-5	DIA_INV_PRO_COND	NF	UNCERTAIN (5) 0,2,4
# 3-6	FCI Reserved (Not Used)	—	—
# 3-7	DIA_MAINTENANCE	NF	GOOD (1) ALL
# 4-0	DIA_MAINTENANCE_ALARM	F	BAD (4) 0, 2, 4
# 4-1	FCI Reserved (Not Used)	—	—
# 4-2	DIA_MAINTENANCE	NF	GOOD (1) 0,2,4
# 4-3	DIA_MAINTENANCE	NF	GOOD (1) 0,2,4
# 4-4	DIA_MAINTENANCE_ALARM	F	BAD (4) 0, 2, 4
# 4-5	DIA_MAINTENANCE	NF	GOOD (1) ALL
# 4-6	DIA_MAINTENANCE	NF	GOOD (1) ALL
# 4-7	DIA_MAINTENANCE	NF	GOOD (1) ALL
# 5-0	DIA_MAINTENANCE	NF	GOOD (1) ALL
# 5-1	DIA_MAINTENANCE	NF	GOOD (1) ALL
# 5-2	DIA_MAINTENANCE	NF	GOOD (1) ALL
# 5-3	FCI Reserved (Not Used)	—	—
# 5-4	FCI Reserved (Not Used)	—	—
# 5-5	FCI Reserved (Not Used)	—	—
# 5-6	FCI Reserved (Not Used)	—	—
# 5-7	FCI Reserved (Not Used)	—	—

CONDENSED DIAGNOSIS TABLE

<i>Condensed DIAGNOSIS Mnemonic</i>	<i>Description</i>
DIA_MAINTENANCE	Maintenance required
DIA_MAINTENANCE_ALARM	Failure of the device or armature
DIA_MAINTENANCE_DEMANDED	Maintenance demanded
DIA_FUNCTION_CHECK	Device is in function check mode or in simulation or under local control (i.e., maintenance).
DIA_INV_PRO_COND	The process conditions do not allow to return valid values. Set if a value has the quality Uncertain – Process related, in maintenance, or Bad – Process related, no maintenance

PROCESS VARIABLES CODE (STATUS)	
0	= VOLUMETRIC FLOW
1	= VOLUME (TOTALIZER)
2	= MASS FLOW
3	= MASS (TOTALIZER)
4	= VELOCITY FLOW
5	= TEMPERATURE

INTENTIONALLY LEFT BLANK

Appendix B – Customer Service/Technical Support

FCI provides full in-house technical support. Additional technical representation is also provided by FCI field representatives.

By Mail

Fluid Components International LLC
1755 La Costa Meadows Dr.
San Marcos, CA 92078-5115 USA
Attn: Customer Service Department

By Phone

Contact the area FCI regional representative. If a field representative is unable to be contacted or if a situation is unable to be resolved, contact the FCI Customer Service Department toll free at 1 (800) 854-1993.

By Fax

To describe problems in a graphical or pictorial manner, send a fax including a phone or fax number to the regional representative. Again, FCI is available by facsimile if all possibilities have been exhausted with the authorized factory representative. Our fax number is 1 (760) 736-6250; it is available 7 days a week, 24 hours a day.

By Email

FCI Customer Service can be contacted by email at: techsupport@fluidcomponents.com.

Describe the problem in detail making sure a telephone number and best time to be contacted is stated in the email.

International Support

For product information or product support outside the contiguous United States, Alaska, or Hawaii, contact your country's FCI International Representative or the one nearest to you.

After Hours Support

For product information visit FCI at www.fluidcomponents.com. For product support call 1 (800) 854-1993 and follow the prerecorded instructions.

Point of Contact

The point of contact for service, or return of equipment to FCI is your authorized FCI sales/service office. To locate the office nearest you, go to www.fluidcomponents.com.

INTENTIONALLY LEFT BLANK



*Flow & Level Instrumentation
Solutions for Industrial Processes*

**FCI's Complete Customer Commitment. Worldwide
ISO 9001 and AS9100 Certified**

Visit FCI on the Worldwide Web: www.fluidcomponents.com

FCI World Headquarters

1755 La Costa Meadows Drive | San Marcos, California 92078 USA | Phone: 760-744-6950 Toll Free (US): 800-854-1993 Fax: 760-736-6250

FCI Europe

Persephonestraat 3-01 | 5047 TT Tilburg, The Netherlands | Phone: 31-13-5159989 Fax: 31-13-5799036

FCI Measurement and Control Technology (Beijing) Co., LTD | www.fluidcomponents.cn

Room 107, Xianfeng Building II, No.7 Kaituo Road, Shangdi IT Industry Base, Haidian District | Beijing 100085, P. R. China
Phone: 86-10-82782381 Fax: 86-10-58851152

Notice of Proprietary Rights

This document contains confidential technical data, including trade secrets and proprietary information which is the property of Fluid Components International LLC (FCI). Disclosure of this data to you is expressly conditioned upon your assent that its use is limited to use within your company only (and does not include manufacture or processing uses). Any other use is strictly prohibited without the prior written consent of FCI.