

Installation, Operation & Maintenance Manual

Installation, Betrieb und Wartungshandbuch
Manual de Instalación, Operación y Mantenimiento
安裝、操作和维护手册

ST100 Series
Thermal Mass Flow Meter

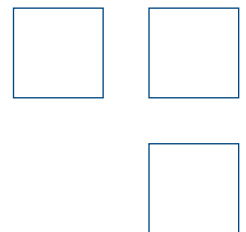

Notice of Proprietary Rights

This document contains confidential technical data, including trade secrets and proprietary information which is the property of Fluid Components International LLC (FCI). Disclosure of this data to you is expressly conditioned upon your assent that its use is limited to use within your company only (and does not include manufacture or processing uses). Any other use is strictly prohibited without the prior written consent of FCI.

© Copyright 2017 by Fluid Components International LLC. All rights reserved. FCI is a registered trademark of Fluid Components International LLC. Information subject to change without notice.

Table of Contents

1 GENERAL	1
Product Description.....	1
Theory of Operation	1
Safety Instructions.....	1
Order Verification.....	1
Hardware - Model Descriptions.....	1
Documentation and Accessories	2
Supplemental Manuals, Optional	2
Supplemental Software, Optional	2
Technical Specifications	3
2 INSTRUMENT INSTALLATION	7
Instrument Identification and Outline Dimensions.....	7
Insertion Sensor Installation.....	7
Flange Mount.....	9
NPT Pipe Thread Mount	9
Adjustable/Retraceable Packing Gland Mounting.....	10
STP100 and STP102A Flow Element Installation	10
Flow Element Wiring.....	10
STP100/102A Electronics Description	10
Troubleshooting.....	11
ST102A and STP102A Flow Element Installation.....	11
Installed Point Locations	11
Flow Element Wiring.....	12
ST/STP102A Electronics Description.....	12
Troubleshooting.....	13
In-Line Sensor Installation.....	13
Flow Transmitter Electronics Installation	13
ESD Precautions.....	13
Integral Electronics	14
Remote Electronics.....	14
Remote Pipe Mounting	15
Instrument Wiring.....	16
Power Fuse Replacement.....	17
Post Installation Check	18
3 OPERATION	19
Basic Commissioning and Start-Up.....	19
HMI Display Menu Navigation.....	19
Verify Engineering Units	20
System Faults, Alarms and Logging Indication	20
ST100 Configuration Software Application (User Password: 2772).....	21
Real Time Clock.....	22
Totalizer Setup	22
Process Data Logging	23
Accessing the microSD Memory Card.....	23
Log File Naming Convention	23

Process Data Logging Configuration	24
Process Data Log File Handling	24
Remove microSD Card from the Instrument and Manually Transfer Files with a Card Reader	24
Upload Selected Log File(s) to a PC Using a USB Cable and the ST100 Configuration Application	25
Internal Delta-R Resistor Check.....	25
Running the Internal Delta-R Resistor Check	25
Analog Output Response to IDR Check	27
Extended Operation Modes	27
Basic	27
External Input Flow Adjust (EIA)	28
External ST100 Flow Input (EFI)	29
Auto FE Calibration Group Switching (FCS)	30
External Control Group Switching (EGS).....	31
4 MAINTENANCE.....	33
Calibration.....	33
Electrical Connections	33
Remote Enclosure	33
Electrical Wiring	33
Flow Element Connections	33
Flow Element Assembly.....	33
5 TROUBLESHOOTING	35
Quick Check.....	35
General Function Check	36
Setup Verification	36
Application Verification	37
Equipment Needed.....	37
Check Serial Numbers.....	37
Check for Moisture.....	37
Check Application Design Requirements.....	37
Verify Standard Versus Actual Process Conditions.....	38
Check the Hardware	38
Troubleshooting the Flow Element.....	39
Integral Flow Element Resistance Table.....	39
Remote Flow Element Resistance Table.....	40
Check the Flow Element Voltages.....	41
Verification of the Electronics.....	42
Check the Flow Transmitter Power Supply Voltages	42
Transmitter Circuit Calibration Check (Delta R Verification).....	42
Equipment Needed.....	42
Alternate Tool for FES-200	42
Safety Instructions.....	42
Delta R Check.....	42
Heater Current Check.....	43
Allowable Limits	44
Output Verification using the ST100 Configuration Application.....	47
Defective Parts.....	47

APPENDIX A	OUTLINE DIMENSIONAL DRAWINGS	49
APPENDIX B	WIRING DIAGRAMS	59
	Figure B-1 – Integral: AC Input Power, Analog and HART Output.....	60
	Figure B-2 – Remote: AC Input Power, Analog and HART Output.....	60
	Figure B-3 – Integral: DC Input Power, Analog and HART Output.....	61
	Figure B-4 – Remote: DC Input Power, Analog and HART Output.....	61
	Figure B-5 – Integral: AC Input Power, FOUNDATION Fieldbus Output.....	62
	Figure B-6 – Remote: AC Input Power, FOUNDATION Fieldbus Output.....	62
	Figure B-7 – Integral: DC Input Power, FOUNDATION Fieldbus Output.....	63
	Figure B-8 – Remote: DC Input Power, FOUNDATION Fieldbus Output.....	63
	Figure B-9 – Integral: AC Input Power, Modbus Output.....	64
	Figure B-10 – Remote: AC Input Power, Modbus Output.....	64
	Figure B-11 – Integral: DC Input Power, Modbus Output.....	65
	Figure B-12 – Remote: DC Input Power, Modbus Output.....	65
	Figure B-13 – Remote: 8-Conductor Interconnection Cable.....	66
	Figure B-14 – Source, Pulse/Frequency Output.....	66
	Figure B-15 – Sink, Pulse/Frequency Output.....	67
	Figure B-16 – Flow Element Connection, Integral/Remote.....	67
	Figure B-17 – Flow Element Connection, Remote.....	68
	Figure B-18 – Remote: 10-Conductor Interconnection Cable.....	68
	Figure B-19 – Extended Operation Mode, External Input Flow Adjust (EIA).....	69
	Figure B-20 – Extended Operation Mode, External ST100 Flow Input (EFI).....	69
APPENDIX C	ADDITIONAL INFORMATION	71
	Delta R Sheet (Sample).....	72
	Parameters Report from the ST100 Configuration Application (Sample).....	73
	HMI Menu Outline (v2.99).....	77
	Internal Delta-R Resistor Check (IDR) HMI Display Sequence.....	78
	ST100 Configuration Software Menu Outline (v2.2.0.x).....	79
	Instructions: Installing Ferrite Onto ST100 Series DC Power Cable.....	83
APPENDIX D	GLOSSARY	85
APPENDIX E	APPROVALS	87
APPENDIX F	CUSTOMER SERVICE	95
	Customer Service/Technical Support.....	95
	Warranty Repairs or Returns.....	95
	Non-Warranty Repairs or Returns.....	95
	Extended Warranty.....	96
	Return to Stock Equipment.....	96
	Field Service Procedures.....	96
	Field Service Rates.....	96
	Return Authorization Request.....	97

Intentionally Left Blank

1 GENERAL

Product Description

The ST100 Series is a thermal dispersion, industrial process grade air/gas flow meter. It is suitable for all air and gas flow measurement applications in line sizes from 1" to 100" [25 to 2500 mm] and larger. The instrument provides direct mass flow measuring and measures flow rate, totalized flow and temperature, and the STP versions add pressure measurement.

The measurements are made available to the user by way of 4-20 mA analog output channels with HART or pre-selected digital bus protocols. The optional graphics display provides real-time process variable values along with flow range and process description information.

There are no moving parts to clean or maintain. A wide selection of process connections are offered to fit with any process piping. Versions are available for temperature service from -40 °F [-40 °C] to 850 °F [454 °C].

The ST100 Series electronics/transmitter can be integrally mounted with the flow sensor or remote mounted up to 1000' [300m] from the sensor element. Additional patented and/or FCI exclusive features include VeriCal® in-situ calibration verification, SpectraCal™ user selectable gas mixes, dual sensor/single transmitter models, and a built-in data logger capable of storing more than 20M readings. All ST100s are precision calibrated in FCI's world-class, NIST traceable calibration facility on one of our flow stands matched to your gas application and actual installation conditions.

Theory of Operation

The instrument is functionally based on the thermal dispersion operating principal. A low powered heater produces a temperature differential between two resistance temperature detectors (RTDs) by heating one of the RTDs above process temperature. As the process mass flow rate changes, the differential temperature between the RTDs changes. The differential temperature between the RTDs is proportional to the process mass flow. The flow transmitter converts the RTD differential temperature signal into a scaled flow output signal. The signal from the unheated RTD is used to provide the process temperature value.

Safety Instructions

Warning: Explosion Hazard. Do not disconnect equipment when flammable or combustible atmosphere is present.

- Field wiring shall be in accordance with NEC (ANSI-NFPA 70) or CEC (CSA C22.1) locations as applicable.
- The instrument must be installed, commissioned and maintained by qualified personnel trained in process automation and control instrumentation. The installation personnel must ensure the instrument has been wired correctly according to the applicable wiring diagram.
- All location specific installation and wiring requirements must be met and maintained. FCI recommends an input power circuit breaker be installed between the power source and the flow meter. This facilitates easy power disconnection during commissioning and maintenance procedures. **A switch or circuit breaker is required if installation is in a hazardous area.**
- The flow meter contains electrostatic discharge (ESD) sensitive devices. Use standard ESD precautions when handling the circuit board assemblies.
- Hazardous Areas: The instrument is designed for use in hazardous areas. The approved area classification is identified on the nameplate along with the temperature and pressure limitations. The USB port and the serial communication port do not support the hazardous area requirements and should only be used when the area is declassified. Remove any non-certified parts such as plastic protection caps from cable entry ports and replace by suitable wiring and cabling system certified by notified bodies for use in Hazardous areas.
- When mounting the flow element into the process pipe, it is important that a lubricant/sealant is applied to the mating threads. Use a lubricant/sealant that is compatible with the process media. Tighten all connections firmly. To avoid leaks do not overtighten or cross-thread connections.

Order Verification

- Verify the received hardware matches the purchased hardware and application requirements. Verify the Model number part number on the instrument I.D. tag (i.e. ST100 – 10CO...) matches the purchased Model number part number.
- Review the Calibration requirements as specified on the Engineering Data Sheet in the documentation package. Verify the flow, temperature and pressure limits meet the application requirements.

Hardware - Model Descriptions

ST100 – Single point insertion element with flow and temperature process output

ST100L – In Line element with flow and temperature process output

ST102 – Dual point insertion elements with flow and temperature process output

ST110 – Single point insertion element with flow and temperature process output, VeriCal option

ST112 – Dual point insertion elements with flow and temperature process output, VeriCal option

- STP100 – Single point insertion element with flow, temperature and pressure process output
STP102 – Dual point insertion elements with flow, temperature and pressure process output
STP110 – Single point insertion element with flow and temperature process output, VeriCal option
STP112 – Dual point insertion elements with flow and temperature process output, VeriCal option

Documentation and Accessories

- 06EN003400 Installation and Operation Manual
06EN003403 ST100 Configuration Software Manual
Calibration Certification Documentation
PC Configuration Software and USB Cable

Supplemental Manuals, Optional

- 06EN003404 HART Operation Manual
06EN003405 FOUNDATION™ Fieldbus Manual
06EN003406 Modbus Operation Manual
06EN003407 PROFIBUS Operation Manual
06EN003408 VeriCal In-Situ Calibration Verification Operation Manual

Supplemental Software, Optional

- HART DD Files
FOUNDATION Fieldbus
PROFIBUS DD File
PDM/DTMs

Technical Specifications

Instrument

■ Measuring Capability

ST1XX Models: Flow rate, total flow and temperature

STP1XX Models: Flow rate, total flow, temperature and pressure

■ Basic Style

ST100: Insertion, single-point

ST100L: In-line (spool piece), single-point

ST102: Insertion, dual-element system

ST110: Insertion, single-point with VeriCal™ capability

ST112: Insertion, dual-element system with VeriCal capability

STP100: Insertion, single-point with pressure measurement

STP102: Insertion, dual-element system with pressure measurement

STP110: Insertion, single-point with pressure measurement and VeriCal capability

STP112: Insertion, dual-element system with pressure measurement and VeriCal capability

■ Flow Measurement Range

Insertion Style: 0.25 SFPS to 1000 SFPS [0,07 NMPS to 305 NMPS]

ST100L In-line: 0.0062 SCFM to 1850 SCFM

[0.01 Nm³/h to 3,140 Nm³/h]

– Air at standard conditions; 70 °F and 14.7 psia [21 °C and 1,01325 bar (a)]

■ Temperature Measurement Range

Up to 850 °F [454 °C] commensurate with element; see Operating Temperature in Flow Element specification

■ Pressure Measurement Range (STP Models)

Available Ranges:

0 psig to 50 psig [0 bar (g) to 3,4 bar (g)]

0 psig to 160 psig [0 bar (g) to 11 bar (g)]

0 psig to 500 psig [0 bar (g) to 34 bar (g)]

0 psig to 1000 psig [0 bar (g) to 70 bar (g)]

■ Environmental Conditions

Maximum Relative Humidity: 93%

Maximum Elevation: 6561' [2000m]

■ Media:

All gases that are compatible with the flow element material

■ Accuracy:

Flow:

Gas Specific Calibration: ± 0.75% reading, ± 0.5% full scale

SpectraCal Gas Equivalency: Typically ± 4% reading, ± 0.5% full scale;

gas conditions specific to application will determine accuracy; utilize FCI's online tool, AVAL, to evaluate your application and provide expected accuracy

Temperature: ± 2 °F [± 1.1 °C] (display only, flow rate must be greater than 5 SFPS [1,5 m/sec])

Pressure (STP Models): ± 0.25% full scale pressure range

■ Temperature Coefficient

With optional temperature compensation; valid from 10% to 100% of full scale calibration

Flow: Maximum ± 0.015% of reading / °F up to 850 °F
[± 0.03% of reading / °C up to 454 °C]

■ Repeatability

Flow: ± 0.5% reading

Temperature: ± 1 °F [± 0.6 °C] (flow rate must be greater than 5 SFPS [1,5 NMPS])

■ Turndown Ratio

Normally factory set and field adjustable from 2:1 to 100:1 within calibrated flow range; up to 1000:1 possible with factory evaluation of application

■ Temperature Compensation

Standard: ± 30 °F [± 16 °C]

Optional: ± 100 °F [± 55 °C]

■ Agency Approvals

FM, FMc: Class I, Division 1, Division 2, Hazardous Locations;

Groups B,C,D,E,F,G

ATEX and IECEx (See page 87)

CPA, NEPSI

■ Calibration

Performed on NIST traceable flow stands and equipment

■ Storage Temperature

-76 to 150°F [-60 to 65 °C]

Flow Element

■ Material of Construction

All-welded 316L stainless steel; Hastelloy-C optional

■ Operating Pressure

Metal ferrule: 1000 psig [69 bar (g)]

Teflon ferrule: 150 psig [10 bar (g)] (200 °F [93 °C] maximum)

Fixed Connection NPT: 1000 psig [69 bar (g)]

Fixed Connection Flanged: per flange rating

STP Models See *pressure sensor specifications*

Same as ST type above or per pressure sensor specification, whichever is lower

Model ST100L In-line style

	Tubing		Sch 40 Pipe		Sch 80 Pipe	
	Psig	Bar(g)	Psig	Bar(g)	Psig	Bar(g)
F Style Sensor						
1"	2400	165	2500	172	3000	207
1 1/2"			1750	121	2500*	172*
2"			1500	103	2250*	155*
S Style Sensor						
1"	2400	165	2500	172	2500	172
1 1/2"			1750	121	2500*	172*
2"			1500	103	2250*	155*

* 1 1/2" and 2" Sch 80 available by special order only; contact FCI
3/4" pipe also available by special order

■ Operating Temperature (Process)

ST100, ST102 Insertion Style

All Flow Elements (– FPC, – FP and – S):

-40 °F to 350 °F [-40 °C to 177 °C]

-40 °F to 500 °F [-40 °C to 260 °C]

-40 °F to 850 °F [-40 °C to 454 °C]

ST110, ST112 Insertion Style

– FP Style Flow Element:

-40 °F to 350 °F [-40 °C to 177 °C]

-40 °F to 500 °F [-40 °C to 260 °C]

STP Series Insertion Style

All Flow Elements (– FPC, – FP and – S):

-40 °F to 257 °F [-40 °C to 125 °C]

ST100L In-line Style

– FP and – S Style Flow Element:
-40 °F to 250 °F [-40 °C to 121 °C]

- **Process Connection**

Compression Fittings: Models ST100 and ST102 only
3/4" or 1" male NPT, stainless steel with adjustable Teflon ferrule or metal ferrule; or flanged tapped and threaded for 3/4" fitting, ANSI or DIN flanges

Compression fittings not available with 850 °F [454 °C] temperature versions of ST100 or ST102

Retractable Packing Glands

Low pressure 50 psig [3,5 bar (g)] or medium pressure 500 psig [34 bar (g)] with graphite or Teflon packing material; 1 1/4" male NPT or ANSI or DIN flange

Teflon packing required when process media is ozone, chlorine or bromine

Fixed Fittings / All Welded

1" male NPT, ANSI or DIN flange

Insertion Length

Field adjustable lengths:

1" to 6" [25 mm to 152 mm]

1" to 12" [25 mm to 305 mm]

1" to 21" [25 mm to 533 mm]

1" to 36" [25 mm to 914 mm]

1" to 60" [25 mm to 1524 mm]

Fixed lengths from 2.6" to 60" [66 mm to 1524 mm]

- **ST100L In-line Flow Tube**

Flow element is calibrated and supplied as a spool-piece; options include low flow injection tubes and built-in Vortab flow conditioners for optimum low flow rangeability and performance

Size: 1" diameter tubing; 1", 1 1/2" or 2" schedule 40 pipe

Length: 9 nominal diameters

Process Connections: Female NPT, male NPT, ANSI or DIN flanges, or butt weld prepared

Option: Flanges sized for flow tube

- **Remote Transmitter Configurations:** Transmitter may be mounted remotely from flow element using interconnecting cable (up to 1000' [300 m])

- **STP Models: Additional Specifications on Pressure Sensor**

Calibrated at nominal 70 °F [21 °C]

Zero/Span Shift: 0.83% full scale/100 °F [1.5% full scale/100 °C]

Zero Tolerance: ± 0.5% of full scale

Span Tolerance: ± 0.5% of full scale

Long Term Stability: ± 0.2% full scale per year

Maximum over Pressure:

50 psi, 100 psi [3,4 bar, 7 bar] versions 3.0 x rated rate range

500 psi, 1000 psi [34 bar, 70 bar] versions 2.0 x rated rate range

Minimum burst Pressure (all):

50 psi, 100 psi [3,4 bar, 7 bar] versions 40 x rated rate range

500 psi, 1000 psi [34 bar, 70 bar] versions 20 x rated rate range

Wetted Materials:

17-4 PH stainless steel diaphragm (*not recommended for hydrogen service; contact FCI for Model STP for use in hydrogen*)

304 stainless steel fittings

Flow Transmitter/Electronics

- **Operating Temperature:**

Single Point System: 0 °F to 140 °F [-18 ° to 60 °C]

Two Point System: 0 °F to 100 °F [-18 ° to 38 °C]

- **Input Power**

AC: 85 Vac to 265 Vac, 50 Hz to 60 Hz

DC - Single Point System: 24 Vdc ± 20%

DC - Two Point System: 23.5 Vdc - 28 Vdc ± 20%

- **Power Consumption**

AC: 85 to 265V = 10W, 1 Flow Element

13.1W, 2 Flow Element

DC: 24V = 9.6W, 1 Flow Element

13.2W, 2 Flow Elements

- **Outputs**

Analog

Standard: Three (3) 4-20 mA*, 0-1kHz, or 0-10 kHz pulse/frequency

4-20 mA outputs are user assignable to flow rate, temperature and/or if so equipped, pressure; outputs are user programmable to full flow range or subsets of full flow range; pulse/frequency output is user selectable as pulse for external counter/flow totalizer, or as 0-1 kHz or 0-10 kHz frequency representing flow rate

HART (comes standard with analog outputs, V7 compliant)

* *Outputs are isolated and have fault indication per NAMUR NE43 guidelines, user selectable for high (>21.0 mA) or low (<3.6 mA)*

Digital

Standard: USB, Ethernet - Service and Configuration Ports Only

Optional: FOUNDATION Fieldbus H1, PROFIBUS PA or Modbus RS-485

FF Physical Parameters

Device Capacitance - Ci (in nF) = 0

Device Inductance - Li (in mH) = 1.01

Maximum Network Input Voltage - Ui (in V) = 32

Maximum Network Input Current - Ii (in mA) = 13

- **Auxiliary Inputs**

One 4-20 mA input channel; used for FCI administered special configurations to allow ST100 Series to accept inputs from external devices such as gas analyzers, gas composition or pressure sensors

- **Enclosures**

Main Transmitter / Electronics:

NEMA 4X, IP67; polyester powder coated aluminum; 4 conduit ports threaded as 1/2" NPT or M20x1.5; 7.74" x 5.40" x 5.00" [196.6 mm x 137.2 mm x 127 mm]; stainless steel enclosure pending

Local Enclosure (Remote Configuration):

Model ST100L, Models ST100 and ST102 without packing gland option:

NEMA 4X, IP67; polyester powder coated aluminum; 2 conduit ports threaded as 1/2" NPT or M20x1.5; 3.75" x 4.00" x 3.24" [95 mm x 102 mm x 82 mm]

Models ST100 and ST102 with medium pressure packing gland option; ST110, ST112 and all STP Models:

NEMA 4X, IP67; polyester powder coated aluminum; 1 conduit port threaded as 1" NPT or M20x1.5; 5.40" x 4.82" [137.2 mm x 122 mm]

- **Data Logger**

User programmable for readings per time increment to a maximum of 1 reading/second; removable, circuit board-mountable 2GB micro-SD (secure digital) memory card supplied; stores approximately 21M readings in ASCII comma-separated format,

■ Readout/Display and optical Touch buttons (optional):

- Large 2" x 2" [50 mm x 50 mm] LCD; digital plus bar graph and engineering units
- Digital displays of flow rate, total flow, temperature and pressure (with STP models); user selectable for engineering units
- Analog bar graph of flow rate
- Alarm status indication
- User programmable 17 alphanumeric character field associated with each calibration group
- Set-Up & Service mode displays text and service codes
- Four (4) optical touch buttons for user programming of instrument set-up and service interrogation
- Optical touch button activation through front window – no need to open enclosure to access or activate
- Display is electronically rotatable in 90° increments to optimize viewing angle

Note: If readout/display not ordered, all user set-up and service interrogation must be done via computer link to bus comm and/or USB port.

Intentionally Left Blank

2 INSTRUMENT INSTALLATION

Warning: Consult the manufacturer if dimensional information on the flameproof joints is necessary.

Warning: The ambient temperature range and applicable temperature class of the ST100 Series flow meter is based on the maximum process temperature for the particular application as follows: T6 for $-40\text{ }^{\circ}\text{C} \leq T_a \leq +65\text{ }^{\circ}\text{C}$; T1 for $-40\text{ }^{\circ}\text{C} \leq T_a \leq +65\text{ }^{\circ}\text{C}$.

Warning: The painted surface of the ST100 Series flow meter may store electrostatic charge and become a source of ignition in applications with a low relative humidity <30% relative humidity where the painted surface is relatively free of surface contamination such as dirt, dust, or oil. Clean painted surfaces using a damp cloth moistened with water only.

Warning: Do not replace internal battery when an explosive gas atmosphere is present.

Instrument Identification and Outline Dimensions

Appendix A provides outline dimensions and mounting bracket dimensions for all integral and remote mounted electronic configurations. Verify all dimensions meet the application requirements before beginning the installation process.

Insertion Sensor Installation

The proper flow meter location in the process piping configuration is critical to the instruments ability to measure the process variables accurately. FCI recommends 20 nominal pipe diameters upstream and 10 pipe diameters downstream of the instrument installation point for most applications. These distances can be significantly reduced when the flow meter is combined with FCI's flow conditioning technology (Vortab).

Insertion flow elements can be mounted into the process using several available customer selectable configurations; compression fitting mounted, threaded or flanged packing gland mounted, and threaded or flanged fixed "U" length mounted process connections. The specific sensor process connection is customer specified on the Order Information Sheet.

Mount the flow element to the process piping per the application piping requirements. Orient the instrument so that the flow arrow etched on the element matches the direction of the process flow with the reference flat parallel to flow within $\pm 3^{\circ}$ of rotation. Insert a flow element with variable insertion length $\frac{1}{2}$ " inch past the centerline of the process pipe or tube with the flow direction arrow correctly aligned and leveled. After the flow element has been located correctly and tightened into place, verify that the process seal does not leak by slowly applying pressure until the maximum operation pressure is applied. Check for leaks at the process connection boundary using standard leak detection methods.

Figure 1 shows a properly mounted compression fitting process connection instrument.

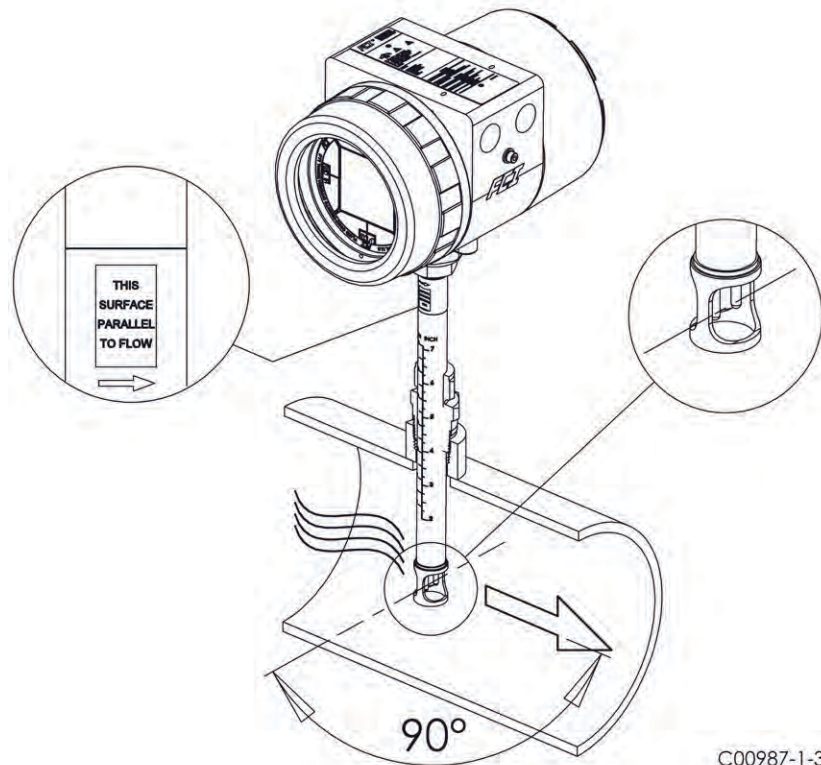

Figure 1

C00987-1-3

Compression Fitting Mounting

1. FCI single point insertion flow meters are calibrated at the centerline of the process pipe. The flow element is properly mounted when the tip of the flow element is located 0.50 inches (13 mm) past the pipe centerline
2. I = Insertion depth
 I.D. = Pipe inside diameter
 T = Pipe wall thickness
 C = Mounting coupling with and installed compression fitting length

Insertion Depth = $I = 0.50 \text{ inches} + (I.D. / 2) + T + C$

3. The scale etched on the side of the insertion pipe indicates the length to the tip of the flow element.
4. Calculate the Insertion depth using the equation in step 2 above.
 I = _____
5. Mark the insertion pipe at the calculated insertion depth.

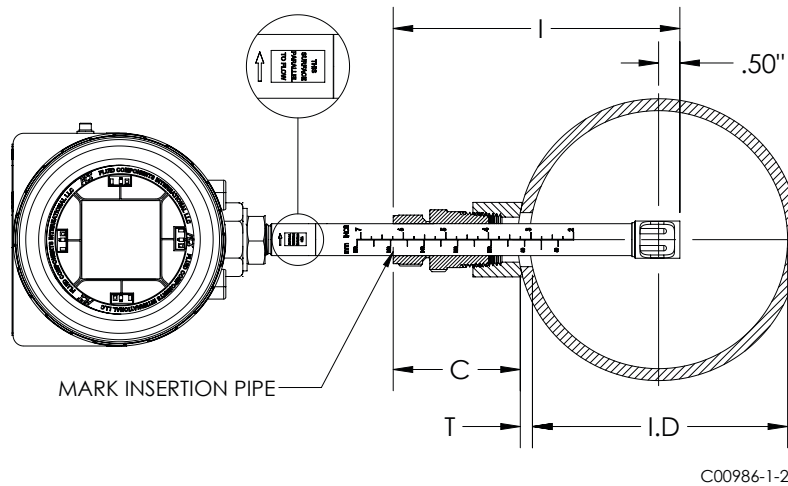

Figure 2

6. Apply proper thread sealant to the tapered pipe thread on the compression fitting and secure into pipe mounting coupling.
7. Insert the flow element to the insertion depth mark and hand tighten the compression nut. Align the orientation flat parallel to the flow direction.
8. Tighten the compression nut to the torque specified for the corresponding ferrule material. Compression fitting manufacture recommends 1-1/4 turns past hand tight.

Ferrule Material	Torque
Teflon	6 FT-Lbs
316 SST	65 FT-Lbs *

Note: The metal ferrule configuration can only be tightened one time. Once tightened, the insertion length is no longer adjustable.

Flange Mount

The flange mount flow element is shown in Figure 3. Attach the process mating flange with care. The correct orientation of the flow element must be maintained to ensure the calibrated accuracy.

- Verify the process media flow matches the flow direction arrow on the flow element.
- Apply appropriate gasket and or sealant to flange mount as required.
- Mate flow element flange to process flange keeping flat oriented properly.
- Secure flanges with appropriate mounting hardware.

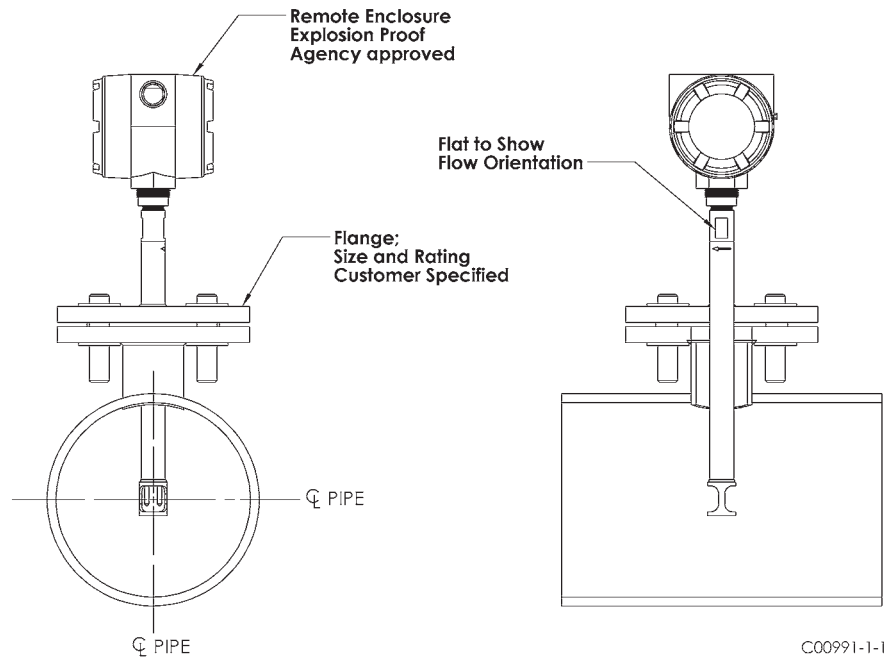

Figure 3

NPT Pipe Thread Mount

The pipe thread configuration is shown in Figure 4. Apply sealant compatible with the process media to male threads. Carefully insert into process mounting coupling. Tighten the flow element until snug and continue until flat and flow direction arrow are aligned with process flow.

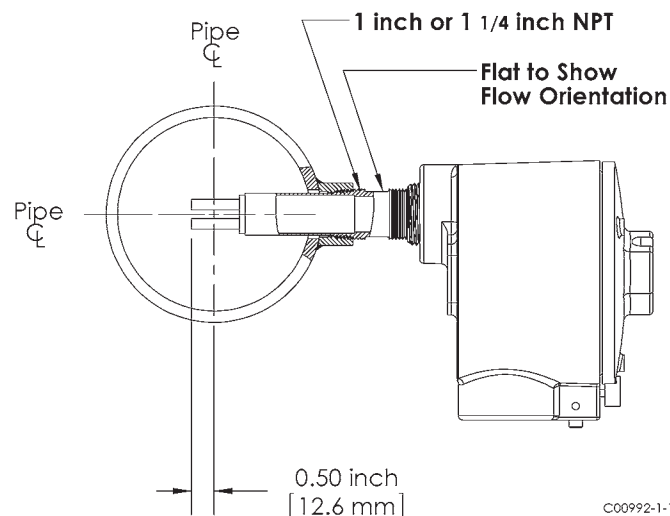

Figure 4

Adjustable/Retraceable Packing Gland Mounting

For applications involving the use of packing glands refer to drawings located in Appendix A for additional detail.

NPT and flange mounted gland are available. Isolation valves are typically used in packing gland applications.

- Follow the pipe thread or flange mount procedures as described in previous sections.
- Tighten the packing nut until the internal packing is tight enough to prevent excess process leakage but also allow the insertion pipe to be inserted into place. Orient the flat and flow arrow properly.
- Proceed to insert the flow element into process media pipe. For the medium pressure packing gland, use the adjusting nuts on the all-thread to pull the flow element into proper position. Tighten the opposing lock nuts.
- Tighten the packing nut another ½ to 1 turn until tight (approximately 65 – 85 ft-lbs)
- On low pressure packing glands, align the split ring collar with connecting strap on packing nut. Tighten the two ¼-28 cap screws on the split ring locking collar.

STP100 and STP102A Flow Element Installation

The Model STP100 and STP102A add an additional pressure transducer measurement as a third process variable output. The process connections available on the STP model include the standard connections available on the ST model except the compression fitting. The ST102 has two probe assemblies. Available process connections include:

- Retractable Packing Gland
- Fixed NPT
- Flanged

All flow element mounting and securing instructions for the selected process connections are identical to the ST100. These details are provided in the previous process connection mounting sections.

The pressure limitation for the STP model will be determined by the selection of the pressure transducer. The available options include 50, 160, 500 and 1000 psig (3.44, 11.03, 34.47 and 69.95 bar) maximum pressure ranges.

The pressure transducer is offered in two different temperature service ranges:

- Standard: 32 to 176°F (0 to 80°C)
- Explosion Proof (Ex): -22 to 212°F (-300 to 100°C)

The pressure transducer is located inside the rectangular shaped enclosure attached to the flow element. The pressure tap is located in the center of the two thermowells and extends through the center of the insertion pipe into the enclosure where the transducer is located. Because the pressure transducer is located several feet away from the process media, at the end of a dead head tube assembly, the pressure transducer will be exposed to the external ambient temperature of the flow element.

Flow Element Wiring

The STP100/102A can be configured with integral or remote electronics. Wiring diagrams for these configurations are located in Appendix B. Remote configurations require a 10-conductor shielded cable as specified in the *Instrument Wiring Table 1*.

STP100/102A Electronics Description

The electronic transmitter for the instrument provides flow, temperature and pressure output on the display and the customer selected output mode, analog or digital.

Analog 4-20mA output: factory default setup

- Output #1 – Flow or Two point average Flow
- Output #2 – temperature or Two point average Temperature
- Output #3 – Pressure

HART output

- Command 9 – Slot 0, 2, 4: Flow or Two point average Flow.
- Command 9 – Slot 5: Temperature or Two point average Temperature
- Command 9 – Slot 6: Pressure

Fieldbus output

- Flow AI Block – Two point average Flow
- Temperature AI Block – Two point average Process Temperature
- Pressure AI Block - Pressure
- Process Transducer block – index 13, PRIMARY_VALUE (Average FLOW)
- Process Transducer block – index 15, SECONDARY_VALUE (Average TEMPERATURE)
- Process Transducer block – index 19, Quaternary_VALUE (Pressure)

Modbus output

- Command 3 – Two point average Flow
Two point average Temperature
Pressure, available on STP models
Totalizer

Troubleshooting

The “Service Mode” for both HART and FOUNDATION Fieldbus provide access to the individual sensor output values.

The 102A electronics transmitter can recognize a disconnected flow element. If this condition is detected, the instrument indicates a fault condition and displays process variable data from the sensor that remains connected to the transmitter. The fault self-corrects when the sensor is re-connected.

ST102A and STP102A Flow Element Installation

The Model ST/STP102A is a dual-element averaging system operating through a single transmitter. The ST/STP102A Flow Element offers the same process connections that are available on the basic ST100. The ST/STP102A has two probe assemblies. Available process connections include:

- Compression Fitting
- Retractable Packing Gland
- Fixed NPT
- Flanged

All flow element mounting and securing instructions for the selected process connections are identical to the ST100. These details are provided in the previous process connection mounting sections. Each flow element is identified with the instrument serial number followed by a -1 or -2.

For example:

Serial no: 409486-1	Description - flow element no.1
Serial no: 409486-2	Description - flow element no.2

Installed Point Locations

The flow element point locations for a two point averaging system are based from the US EPA – Method 1 Traverse Point recommendations. This method is applicable to gas streams flowing in ducts, stacks, and flues with inside diameters greater than 12 inches. The recommended point locations for a two point averaging system are shown in the diagram below.

Locate and secure the flow elements into position using (0.146 x Pipe I.D. + 0.50 inches) as the location dimension from the pipe I.D. to the end of the flow element (Fig. 5).

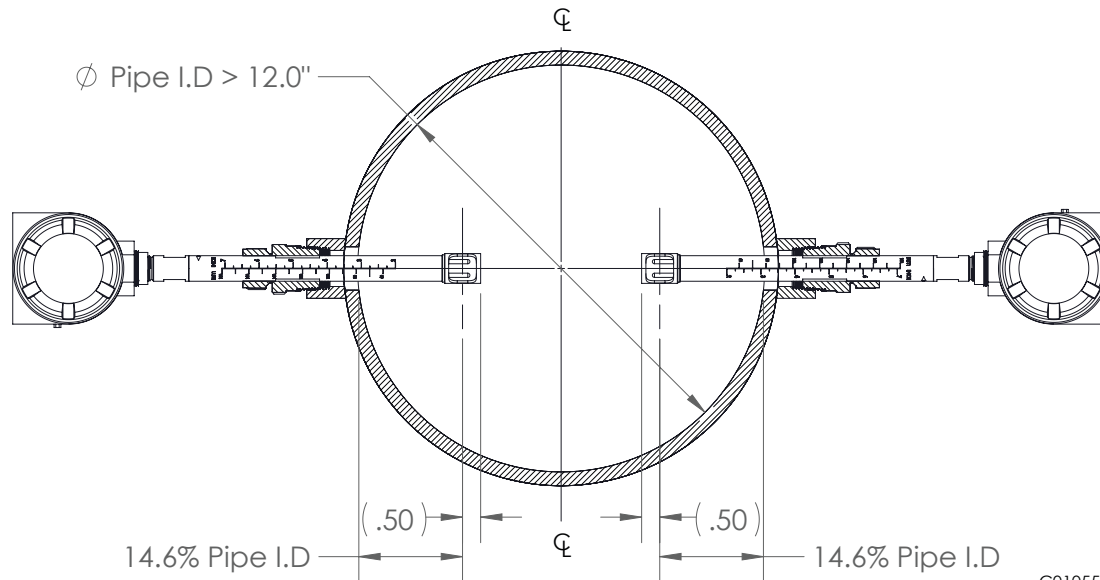

Figure 5

C01055-1-2

Flow Element Wiring

The ST/STP102A can be configured with one integral and one remote flow element or with two separate flow elements and remote electronics. Wiring diagrams for these configurations are located in Appendix B. Each of the flow elements on the ST102A/STP102A are connected to the transmitter using an 8-conductor shielded cable as specified in the *Instrument Wiring Table 1*.

ST/STP102A Electronics Description

The electronic transmitter for the ST/STP102A type instruments provides a two point averaged flow and temperature output on the display and the customer selected output mode, analog or digital.

Analog 4-20mA output: factory default setup

- Output #1 – Two point average Flow
- Output #2 – Two point average Temperature
- Output #3 – Pressure, available on STP models

HART output

- Command 9 – Slot 0, 2, 4: Two point average Flow.
- Command 9 – Slot 5: Two point average Temperature
- Command 9 – Slot 6: Pressure

Fieldbus output

- Flow AI Block – Two point average Flow
- Temperature AI Block – Two point average Process Temperature
- Process Transducer block – index 13, PRIMARY_VALUE (Average FLOW)
- Process Transducer block – index 15, SECONDARY_VALUE (Average TEMPERATURE)

Modbus output

- Command 3 – Two point average Flow
- Two point average Temperature
- Pressure, available on STP models
- Totalizer

Troubleshooting

The "Service Mode" both HART and FOUNDATION Fieldbus provide access to the individual sensor output values.

The ST/STP102A electronics transmitter can recognize a disconnected flow element. If this condition is detected, the instrument indicates a fault condition and displays process variable data from the sensor that remains connected to the transmitter. The fault self-corrects when the sensor is re-connected.

In-Line Sensor Installation

The sensor can be threaded, flanged or butt weld mounted to the process piping. The specific sensor process connection is customer specified on the Order Information Sheet.

Mount the sensor to the process piping per the application piping requirements. Verify the flow direction arrow is pointed in the correct direction. After the sensor head has been located correctly and tightened into place, verify the process seal does not leak by slowly applying pressure until the normal operation pressure is applied. Check for leaks at the process connection boundary.

Flow Transmitter Electronics Installation

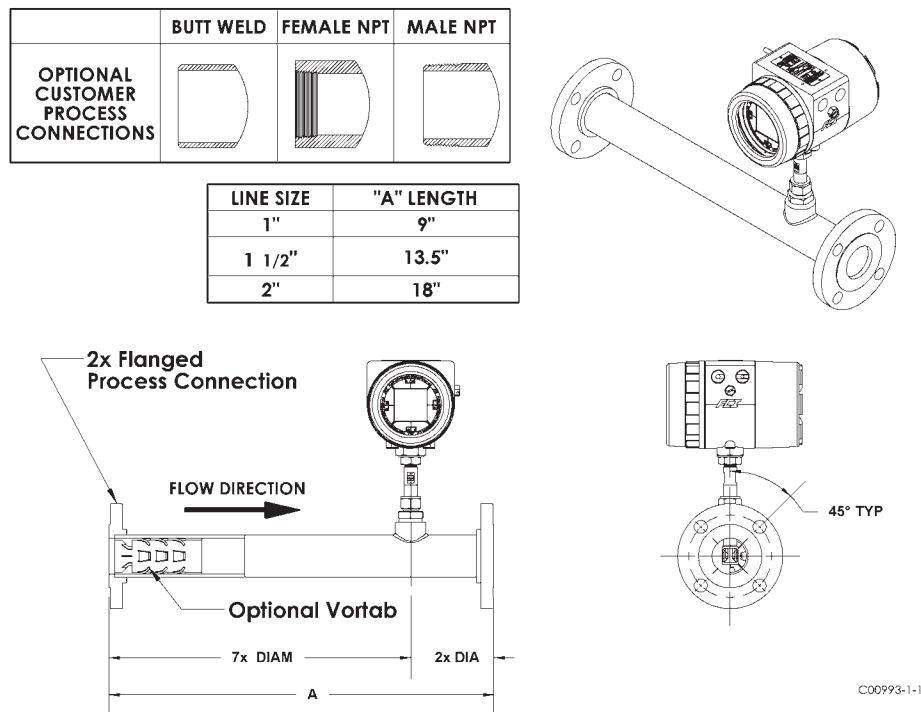

Figure 6

The instrument electronic transmitter can be an integral part of the flow element or it can be mounted remotely using a shielded cable between the flow element and the electronics.

Supply connection wiring must be rated to 90 °C.

ESD Precautions

Caution: FCI flow meters contain static-sensitive devices. To avoid damage to the instrument observe the ESD precautions listed below before opening the instrument for wiring.

- Use a wrist band or heel strap with a 1 MΩ resistor connected to ground.
- Use a static conductive mat on the work table or floor with a 1 MΩ resistor connected to the ground when working on the instrument in a shop setting.
- Connect the instrument to ground.
- Apply antistatic agents such as Static Free made by Chemtronics to hand tools used on the instrument.
- Keep high static-producing items away from the instrument.

The above precautions are minimum requirements. The complete use of ESD precautions can be found in the U.S. Department of Defense Handbook 263.

Integral Electronics

The integral electronics package is mounted during the flow element installation process. The integral electronics can be rotated ± 180 degrees on the top of the flow element insertion pipe. This is done by loosening the lock nut at the base of the enclosure and rotating the enclosure to the preferred orientation. **Do not rotate the electronics enclosure more than ± 180 degrees, damage to internal wiring may result from over rotating the enclosure!**

Lock Nut Torque Specification: 30-35 ft-lbs (40-47 N-m)

Provide integral electronics with additional support/bracing in applications where excessive vibration is present. A mounting bracket is available from FCI to support the electronics when additional support is required.

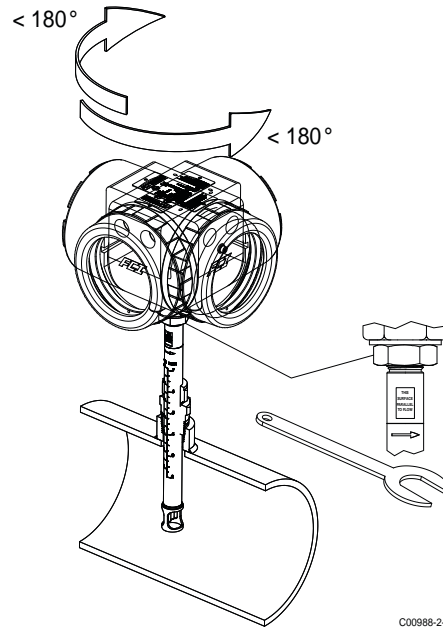

Figure 7

Remote Electronics

A mounting bracket is supplied when the transmitter is ordered for remote mounting. The bracket mounting details are shown in Figure 8 below. Refer to the outline installation drawings in Appendix A for additional mounting details. The electronics can be easily wall or pipe mounted. The mount bracket is designed for .25 inch or M6 mounting hardware. Securely mount the electronics to cement or structural support columns or beams. Mounting to plaster is not recommended and does not meet system approval requirements.

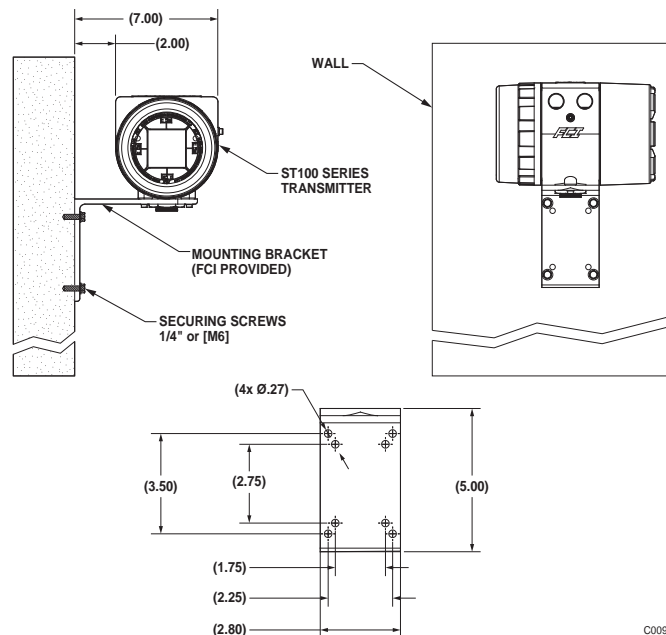

Figure 8

Remote Pipe Mounting

Refer to the figures below for remote transmitter pipe mounting details.

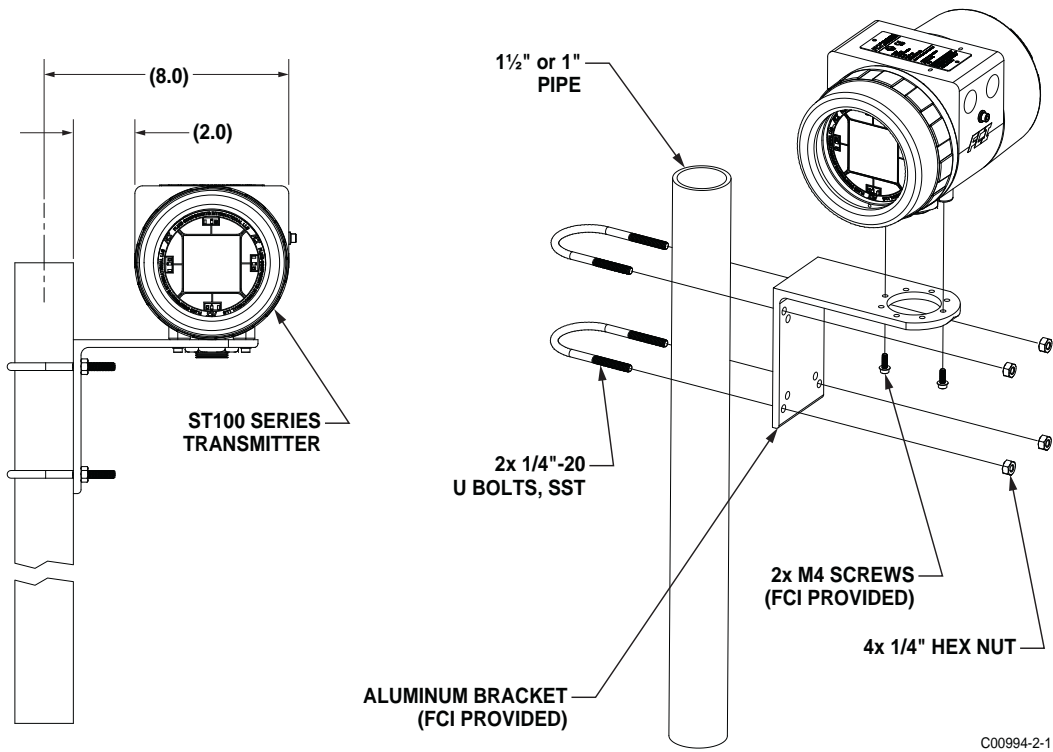

Figure 9

C00994-2-1

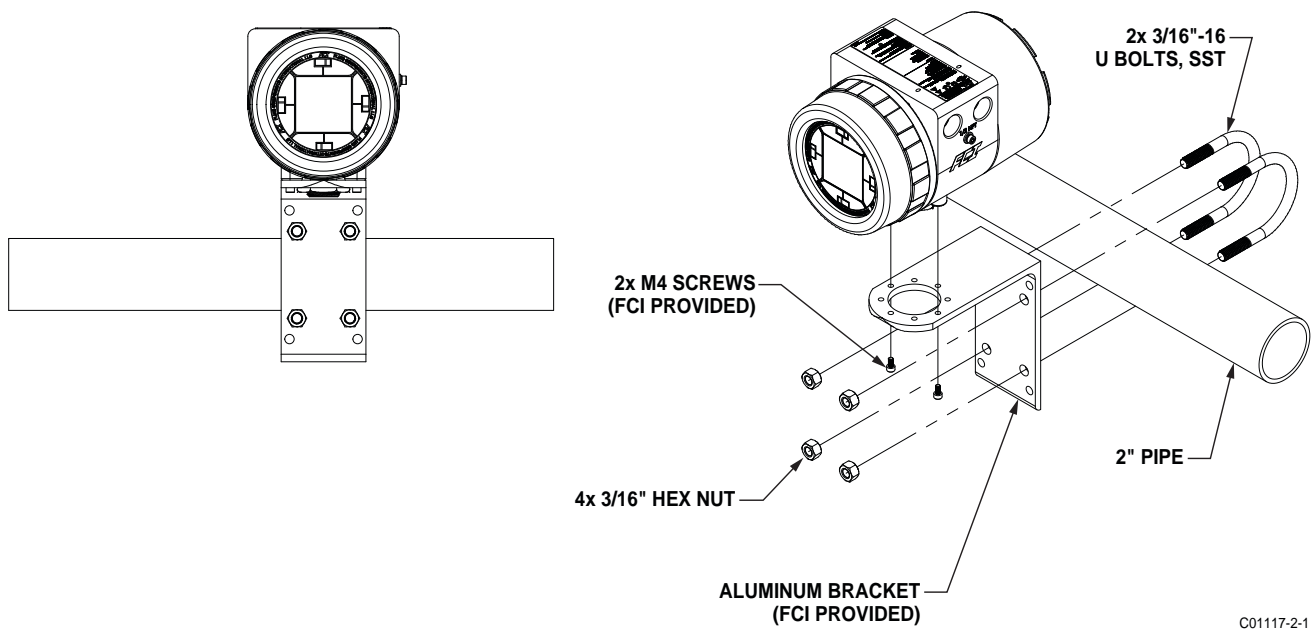
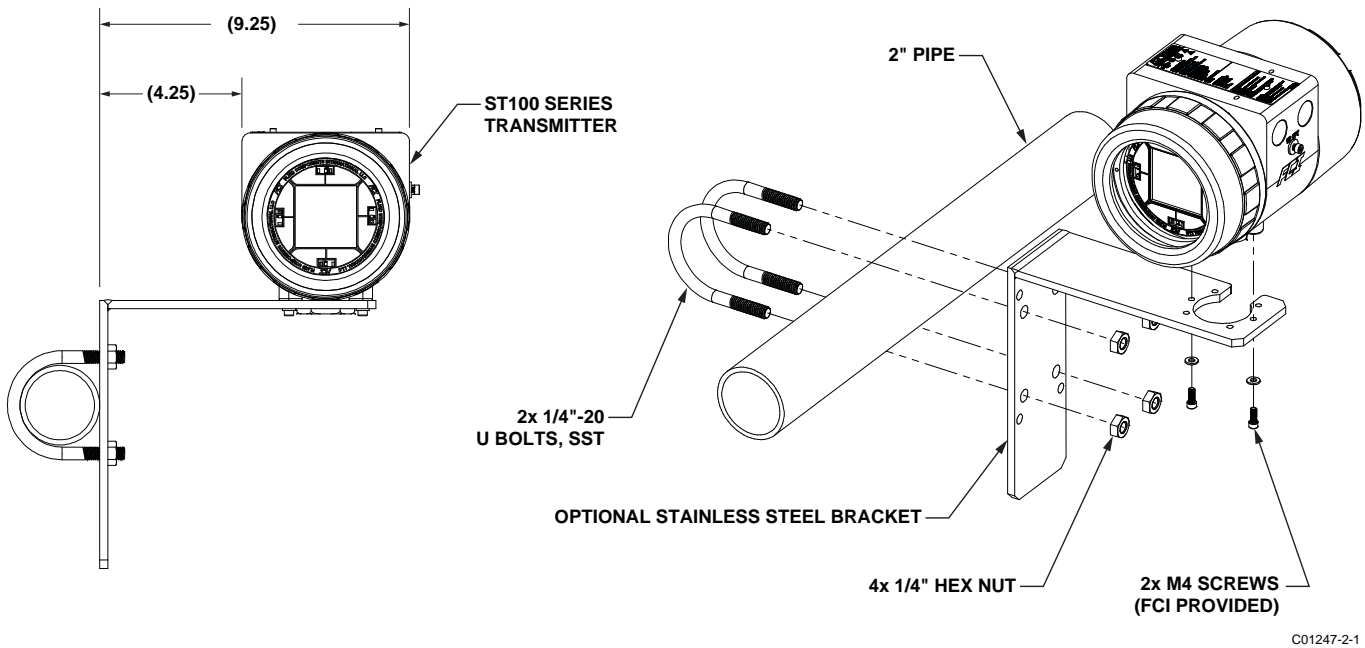

Figure 10

C01117-2-1



C01247-2-1

Figure 11

Instrument Wiring

The flow transmitter can be powered by 85 – 265 Vac or 24 Vdc as specified in the instrument specification. The electronics cannot be configured to switch between AC and DC power. **For 220/265 Vac installations, a neutral reference circuit must be used.**

All cable glands and conduit fittings must meet or exceed the area approval rating where the instrument is being installed.

The recommended instrument wiring routing is shown in Figures 12 and 13.

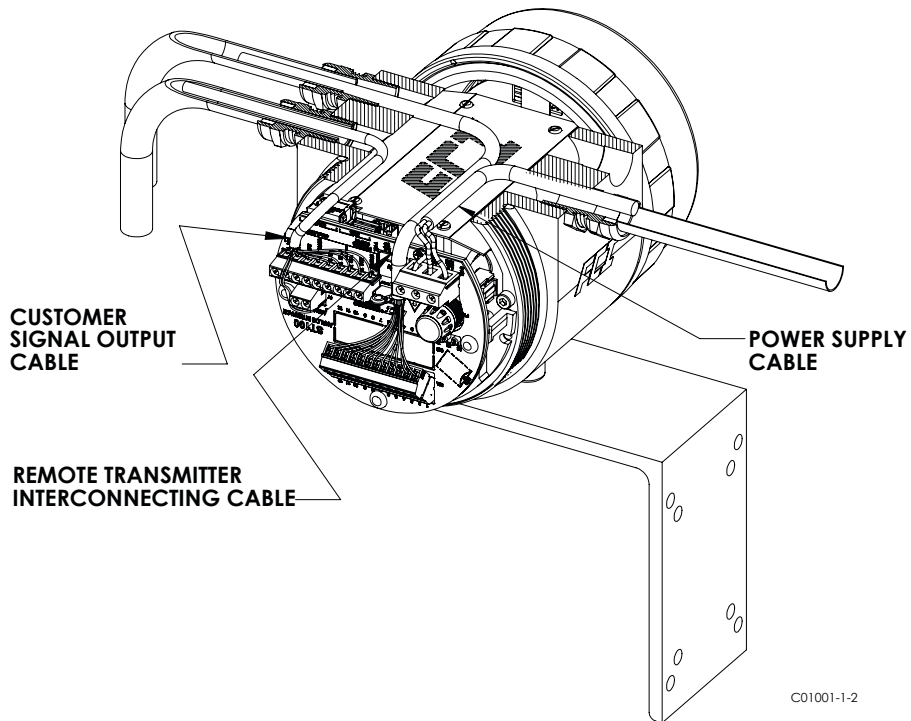

C01001-1-2

Figure 12

DC powered instruments require a ferrite to be installed on the input power wires to meet the EMC directive 2004/108/EC. Refer to the ferrite installation instructions in Appendix C, page 83 for details.

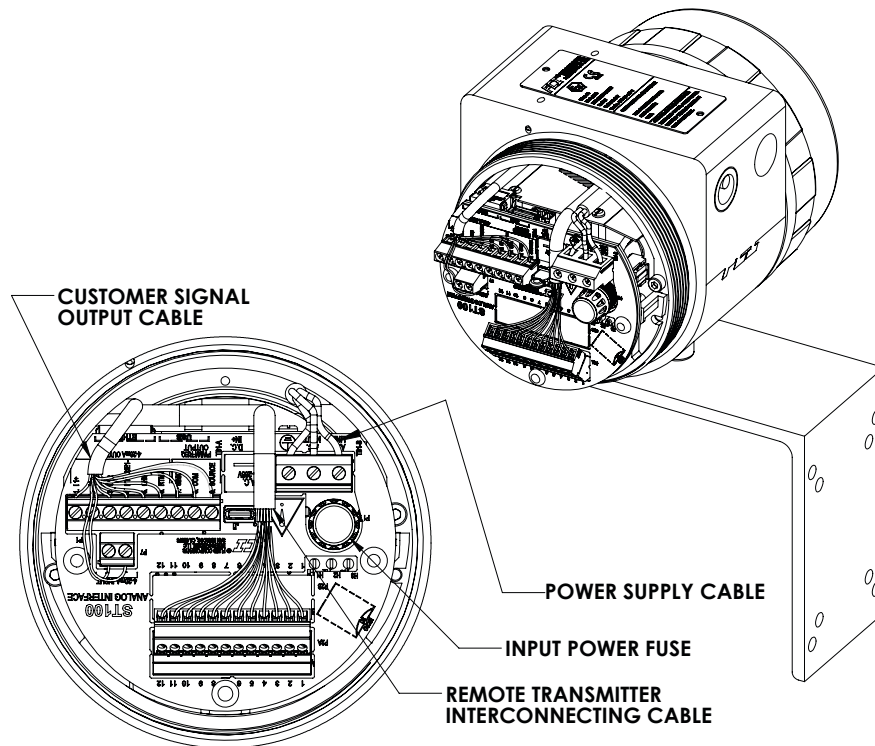

C01001-2-2

Figure 13

Connection	10 ft (3 m)	50 ft (15 m)	100 ft (31 m)	250 ft (76 m)	500 ft (152 m)	1000 ft (305 m)
Power AC or DC	22	22	22	20	18	16
Flow Element (8 Conductor Shielded)	24	24	24	22	22	18
STP Flow Element (10 Conductor Shielded)	22	22	22	22	22	18
Analog Out (HART)	16-30	16-30	16-30	16-30	16-30	16-30
Digital Out FOUNDATION Fieldbus	FF-844 H1 (14-30 AWG)					
Modbus	RS485 (14-30 AWG)					

Instrument Wiring Table 1 - Recommended AWG

Analog output maximum load: 600 ohms

Instrument Power Requirements: See "Technical Specifications" on page 3.

Power Fuse Replacement

Instrument fuse rating and part no:

AC Input Power (85 - 265 Vac):

Mfgr – Littelfuse, 2A TR5 SLO-BLO series 383 (2 amp rating), part no. 38312000000; FCI part no. 022499-01.

DC Input Power (24 Vdc):

Mfgr – Littelfuse, 2A TR5 SLO-BLO series 383 (2 amp rating), part no. 38312000000; FCI part no. 022499-01.

The input power fuse is located on the customer interface board. See Figure 13. **Turn instrument power OFF before replacing the fuse.** To replace the fuse, unscrew the clear fuse cover and pull the fuse straight out of the holder. Replace the fuse with the recommended fuse listed above by aligning the fuse pins with the receiving holes located in the fuse holder and pushing securely into place until the fuse bottoms in the holder. Replace the fuse cover.

Reference the following wiring diagrams in Appendix B for specific integral and remote mounted electronics.

Figure B-1 – Integral: AC Input Power, Analog and HART Output
 Figure B-2 – Remote: AC Input Power, Analog and HART Output
 Figure B-3 : Integral: DC Input Power, Analog and HART Output
 Figure B-4 – Remote: DC Input Power, Analog and HART Output

Figure B-9 – Integral: AC Input Power, Modbus Output
 Figure B-10 – Remote: AC Input Power, Modbus Output
 Figure B-11 – Integral: DC Input Power, Modbus Output
 Figure B-12 – Remote: DC Input Power, Modbus Output

Figure B-5 – Integral: AC Input Power, FOUNDATION Fieldbus Output
 Figure B-6 – Remote: AC Input Power, FOUNDATION Fieldbus Output
 Figure B-7 – Integral: DC Input Power, FOUNDATION Fieldbus Output
 Figure B-8 – Remote: DC Input Power, FOUNDATION Fieldbus Output

Figure B-13 – Remote: 8-Conductor Interconnection Cable
 Figure B-14 – Source, Pulse/Frequency Output
 Figure B-15 – Sink, Pulse/Frequency Output

ST102/STP102

Figure B-16 – Flow Element Connection, Integral/Remote
 Figure B-17 – Flow Element Connection, Remote

STP100/STP102

Figure B-18 – Remote: 10-Conductor Interconnection Cable
 Figure B-19 – Extended Operation Mode, External Input Flow Adjust (EIA)
 Figure B-20 – Extended Operation Mode, External ST100 Flow Input (EFI)

Post Installation Check

Verify all wiring connections are secure and correct to the appropriate wiring diagram. Verify the flow direction arrow on the flow element is pointing in the right direction. Verify the mechanical process connection is secure and meets the system pressure requirements.

3 OPERATION

Basic Commissioning and Start-Up

When all working and process connections have been verified, apply power to the instrument. LCD-equipped instruments briefly show a welcome screen indicating the HMI software version followed by the normal operation process screen. The normal process screen shows: percentage of flow bar, icons (if present), process flow rate, totalized flow (optional), temperature in customer units, pressure (optional) in customer units, calibration group, and group name.

The instrument LCD display functions as a basic HMI (Human-machine Interface) setup tool. The four buttons (IR sensors) located at the 3, 6, 9, and 12 o'clock positions on the display provide access to basic setup parameters. The HMI setup menu can be accessed through the window without removing the electronics enclosure lids. Enter the HMI setup menu by touching the glass in front of the 12 o'clock sensor (Hot Key) for 3 seconds. The LCD acknowledges the button selection by flashing then inverting the display characters and background while the button is held.

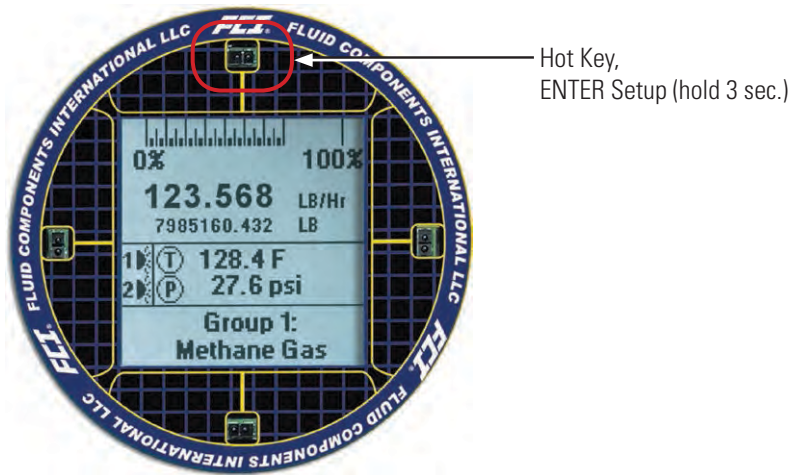

Figure 14

HMI Display Menu Navigation

In the HMI setup mode use the four IR sensors to navigate the menu. Touch/tap the top/bottom sensor to scroll up/down through the menu selections. Tap the right sensor to select. Tap the left sensor to return to the previous menu. Some setup parameters are password protected—when prompted enter the HMI user password: E#C. To immediately exit HMI setup and return to the process display touch the bottom sensor for 2 seconds. Backing out of menus via repeated taps of the left button also exits setup. An overview of the HMI menu structure is shown in Appendix C, page 77.

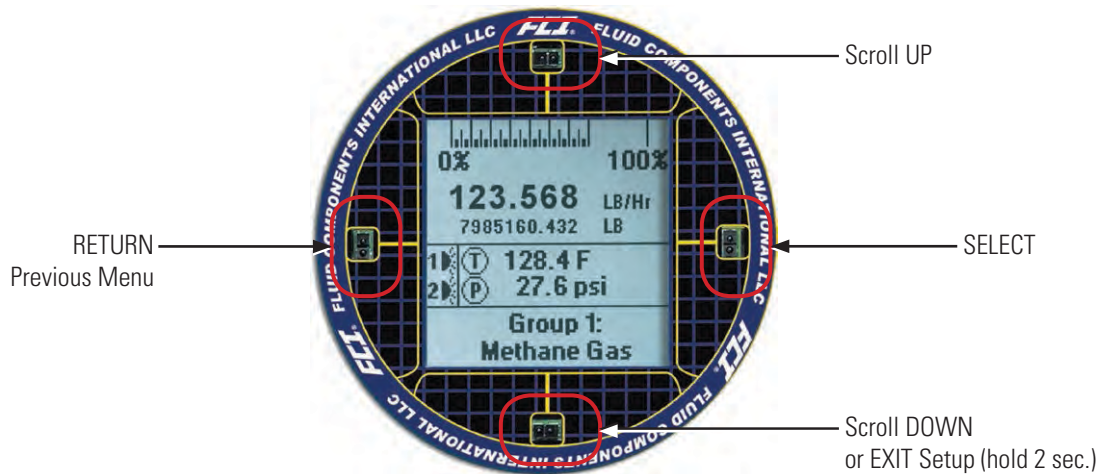

Figure 15

Verify Engineering Units

Verify that the engineering units are correct for flow rate, temperature (and pressure is equipped). Use the HMI to make any necessary changes. The basic functions accessible from the HMI menu are listed in the outline below. For expanded configuration options use the ST100 configuration software application.

System Faults, Alarms and Logging Indication

The ST100 HMI indicates System Faults, Alarms and Logging by displaying three different icons when these conditions are present. These icons appear directly above the flow rate indication on the main process data screen. FAULTS are displayed as a Caution Triangle icon, ALARMS as a Bell icon and LOGGING as a LOG icon.

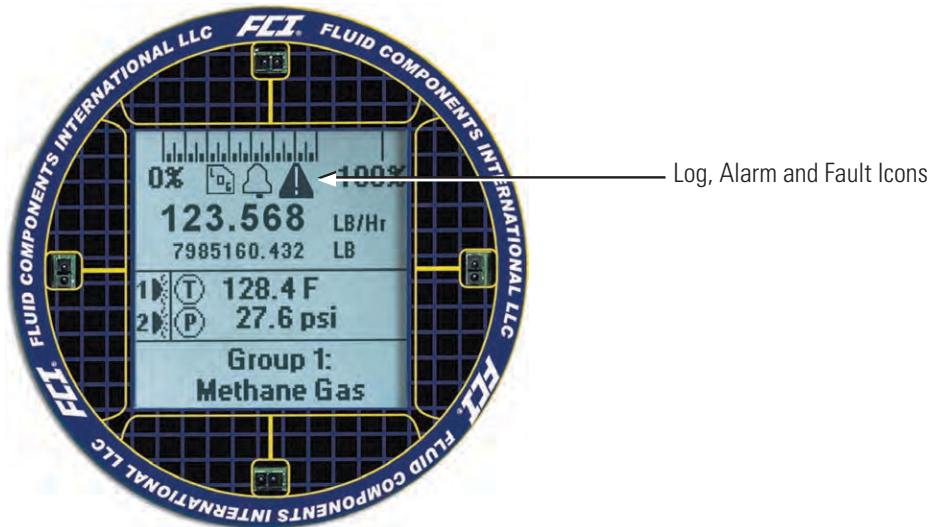



Figure 16

ST100 Configuration Software Application (User Password: 2772)

The ST100 configuration software application provides an alternate and more extensive method for configuring the instrument. However, this requires opening the electronics enclosure and connecting to a PC via the USB port. The ST100 configuration software application is intuitive, easy to use and the preferred method for commissioning the instrument.

Note: An asterisk (*) shown on various menu locations on the HMI indicates that the instrument is connected to the ST100 configuration software application. Note that not all configuration software application menus are accessible via the HMI.

The ST100 series of instruments require a USB 2.0 cable with A-type male connectors on both ends. Connect a USB cable between the computer (with the ST100 configuration software installed) and the USB port on the ST100 Interface Board (remove the blind lid). Launch the application via the PC's desktop ST100 Configurator icon:  An example ST100 configuration software Welcome screen is shown below.



Welcome Screen

The **USB Connect** button is the primary communication method. Ethernet communication is also an option, but it is much slower than USB communication. An example Process Data screen is shown below.

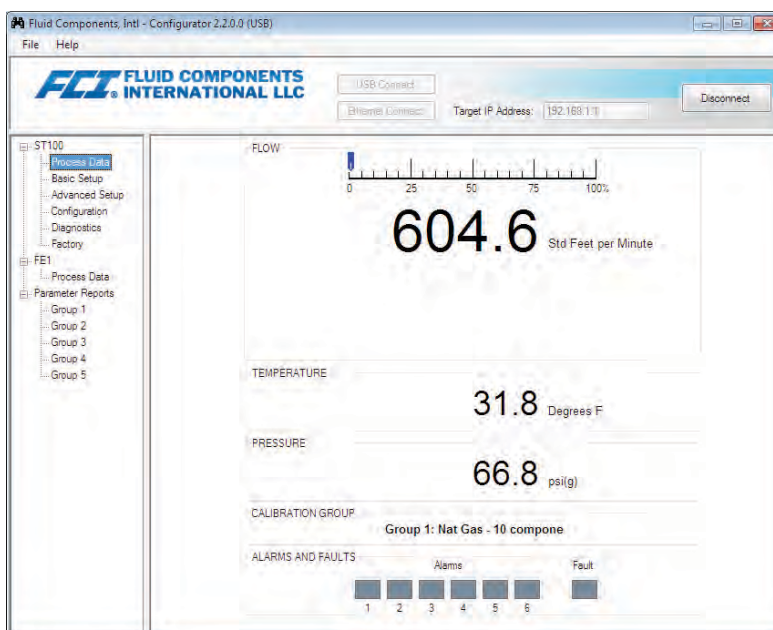

Process Data Screen

With the configuration software running on the attached PC the user has access to all the configurable features of the ST100 series of instruments. If parameter changes are required the User Level Password (2772) is required. For more detailed instructions on the ST100 configuration software application, refer to FCI document number **06EN003403**.

Real Time Clock

The ST100 system time is maintained by a battery-powered real time clock that is set to Pacific Time at the factory. Synchronize the ST100 system time with the user's local time using the ST100 configuration software. The real time clock cannot be set using the HMI menu interface. If the real time clock is not set correctly, or becomes corrupted, the process data logging feature will not work properly.

Start the ST100 configuration software application. Click **USB Connect** on the home screen. Select the *Advanced Setup* branch from the menu tree on the window's left side. Select the **Date and Time** tab.

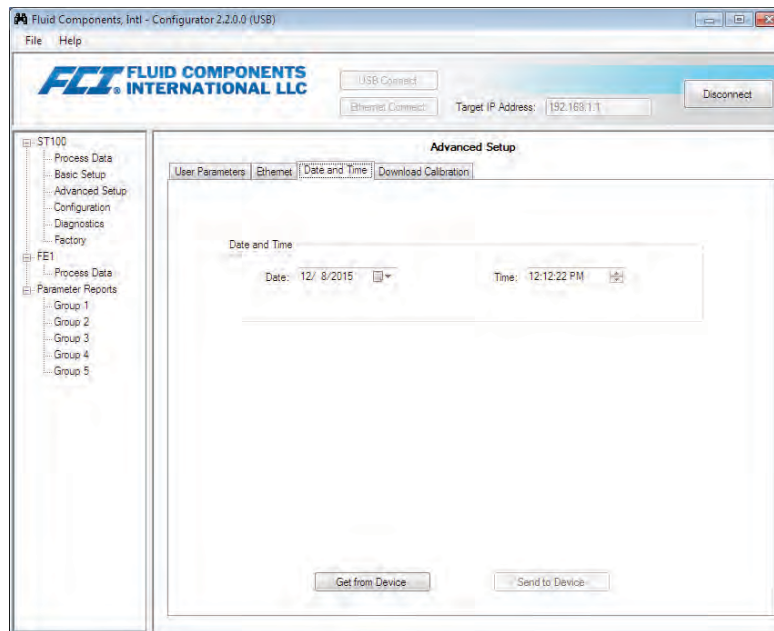

Date and Time Set Screen

Click **Get from Device**. This displays the current date and the ST100 system time. If needed, set the correct date using the field's calendar date picker and time using the field's spinner buttons. Click **Send to Device** to save the changes to the instrument.

Totalizer Setup

The flow totalizer function accumulates the instrument total flow, much like the odometer on an automobile. The engineering flow units must be set in mass or volumetric units for the function to work. The totalized flow value is displayed directly below the indicated flow rate on the instrument HMI display. The totalizer is enabled and displayed by default. Use the ST100 configuration software to set up the totalizer. The totalizer cannot be programmed using the HMI menu interface.

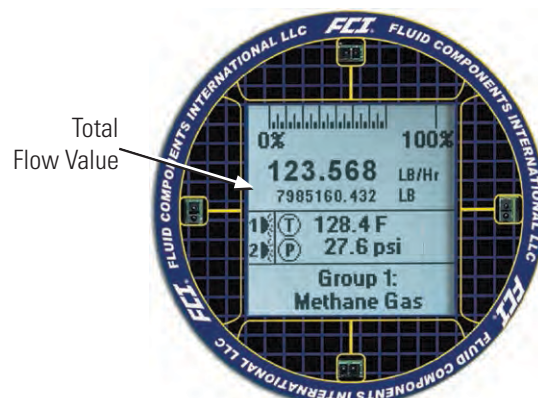
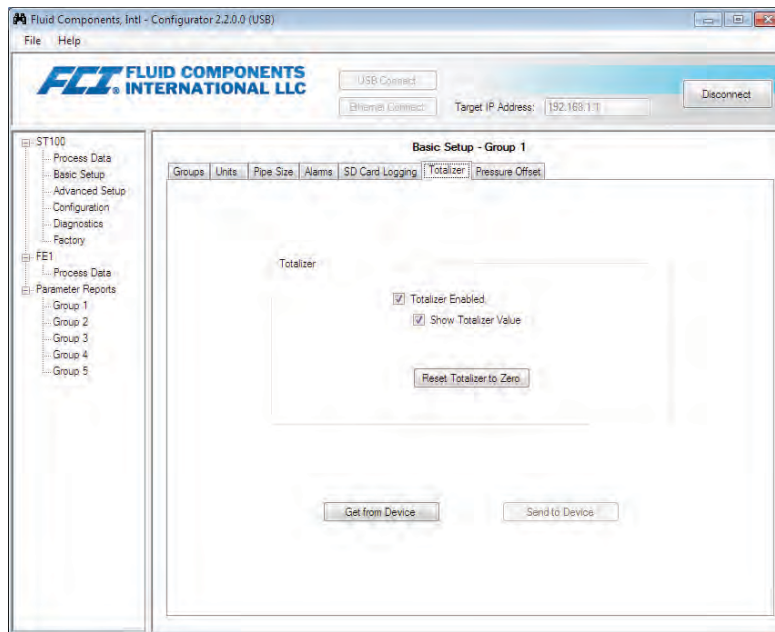

Figure 17

Start the ST100 configuration software application. Click **USB Connect** on the home screen. Select the *Basic Setup* branch from the menu tree on the window's left side. Select the **Totalizer** tab. Configure as desired (check/uncheck the checkboxes). Click **Send to Device** to save the changes to the instrument (enter the user level password 2772 when prompted). Click **Get from Device** to verify any changes.



Totalizer Setup Screen

Process Data Logging

The ST100 has the ability to log process data (date and time, flow rate, temperature, pressure, totalized flow rate and the faults code – all in customer units). This information is stored on the microSD card in the comma separated value (.csv) format without any titles. Use the ST100 configuration software application to set up the process data logging feature. The process data logging feature is disabled by default. The HMI menu interface can only be used to insert or remove the microSD card.

Accessing the microSD Memory Card

The ST100 comes equipped with an 8 GB (max. size) microSD memory card. Access the microSD card by removing the instrument's blind lid. Locate the microSD card by finding the dashed rectangle silkscreened on the interface board with the label "MICRO SD." The card socket is behind this marking on the back side of the PWB assembly with the microSD card edge flush with the board. Push down on the microSD card to eject it from its socket.

Log File Naming Convention

Example log file name: LGCFOI58.CSV (where LG is constant for log file followed by coding for Year (A = 2012, B = 2013, etc.) Month (A = January, B = February, etc.) Day (1 = 1, A = 11, etc.) Hour (A = midnight, B = 1AM, etc.) Minutes (00 to 59).CSV.

Year	Month	Day	Time	Flow Rate	Temperature	Pressure	Totalizer	Faults Code
2014	6	10	8:58:00	89.198631	0.028174	0	69269.365	0x00000000
2014	6	10	8:58:10	89.185516	0.027597	0	69269.613	0x00000000
2014	6	10	8:58:20	89.178818	0.029547	0	69269.861	0x00000000
2014	6	10	8:58:30	89.183357	0.027222	0	69270.109	0x00000000

Log File Entry Example

Process Data Logging Configuration

Start the ST100 configuration application. Click **USB Connect** on the home screen. Select the *Basic Setup* branch from the menu tree on the window's left side. Select the **SD Card Logging** tab.

Process data logging configuration is done in the window's *Logging* section as follows.

- **Start Logging:** Specifies start time of the first log file. Can be either "Start Now" or "Date/Time."
- **Sample Period:** Specifies how often a log file is generated. Can range from once every 10 seconds to once every 24 hours.
- **Duration:** Specifies how long the logging feature remains activated. Can range from 1 minute to 90 days.
- **Cancel Logging:** Used to cancel ST100 logging-in-progress or pending log.
- **Show List of Log Files:** Shows the previously completed log files stored on the microSD card.
- **Upload Selected Log File(s):** Transfers log files from the microSD card to a PC connected to the ST100 USB interface.

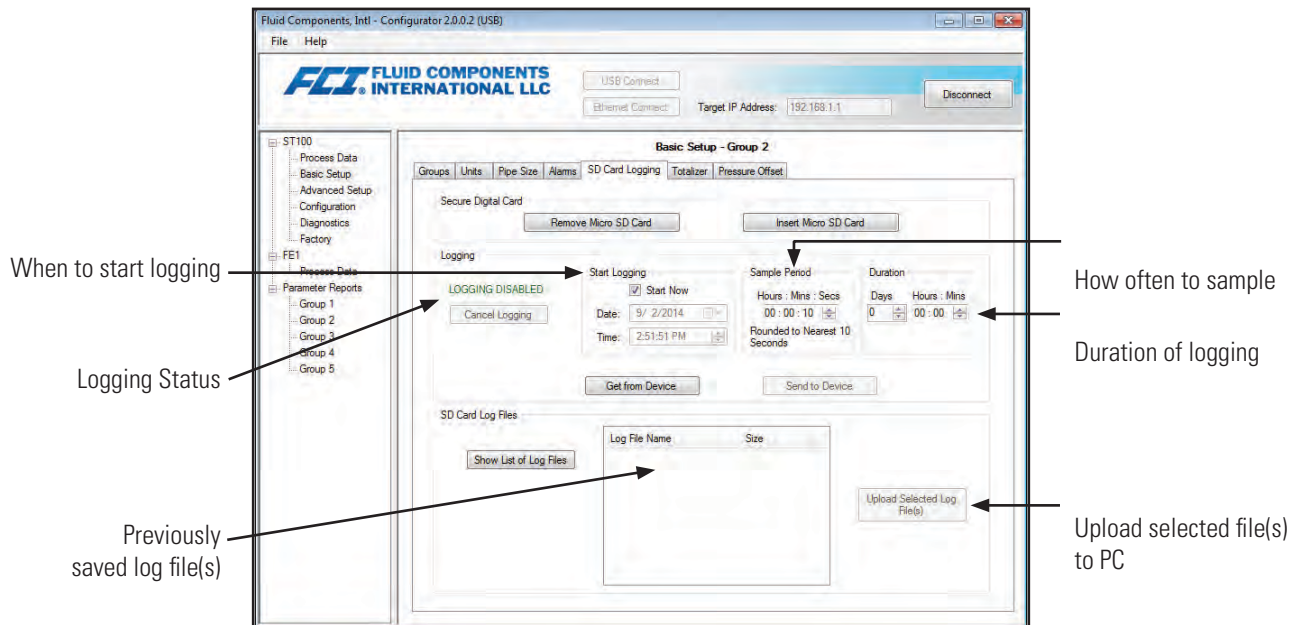

Basic Setup SD Card Logging

Process Data Log File Handling

There are two ways to access the files stored on the microSD card:

- Remove microSD card from the instrument and manually transfer files with a card reader.
- Upload selected log file(s) to a PC using a USB cable and the ST100 configuration application.

Remove microSD Card from the Instrument and Manually Transfer Files with a Card Reader

Using the HMI— Hold the "Hot Key" (top sensor) for three seconds. Select "LoggerSDcard." Select "Remove." This closes any open files on the microSD card allowing it to be removed safely.

Using the ST100 Configuration Application— Click **USB Connect** on the home screen. Select *Basic Setup* branch from the menu tree on the window's left side. Select the **SD Card Logging** tab. Click the **Remove Micro SD Card** button. This closes any open files on the microSD card allowing it to be removed safely.

Open the ST100 enclosure and physically remove the microSD card from the electronics (see page 23). Insert the card into an appropriate card reader. Use a PC to view and/or save the contents as desired. When finished, reinsert the microSD card using either the HMI menu or the ST100 configuration application as follows:

Using the HMI— Physically insert the microSD card into the electronics. Hold the "Hot Key" (top sensor) for three seconds. Select "LoggerSDcard." Select "Inserted." This signals the instrument that the microSD card is present and ready to use. Secure the electronics enclosure and return the ST100 to normal operation.

Using the ST100 Configuration Application— Click **USB Connect** on the home screen. Select the *Basic Setup* branch from the menu tree on the window's left side. Select the **SD Card Logging** tab. Click **Insert Micro SD Card**. Physically insert the microSD card into the electronics. Click **OK** on the pop-up dialog box. This signals the instrument that the microSD card is present and ready to use. Secure the electronics enclosure and return the ST100 to normal operation.

Upload Selected Log File(s) to a PC Using a USB Cable and the ST100 Configuration Application

It is possible to upload selected log file(s) to a PC using a USB cable and the ST100 configuration software application without removing the memory card from the ST100 electronics.

Start the ST100 configuration application. Click **USB Connect** on the home screen. Select the *Basic Setup* branch from the menu tree on the window's left side. Select the **SD Card Logging** tab. In the *SD Card Log Files* frame click **Show List of Log Files**. Select the desired file(s) from the list displayed. Click **Upload Selected Log File(s)**. A file dialog pops up showing the host computer file locations (like Windows Explorer). Select the desired location to store the file and click **OK**. The file is then copied to the specified host computer location.

Internal Delta-R Resistor Check

The Internal Delta-R Resistor Check (IDR) is a routine designed to assess the ST100 internal normalization. The normalization process fine tunes the instrument's ability to accurately measure resistance. Proper normalization also allows FCI electronics to be interchangeable for replacements, spares or repaired boards. If the unit's normalization shifts, the accuracy of the meter may be compromised.

By passing the same sensor excitation current used to power the RTDs across three high precision IDR resistors (60 Ω , 100 Ω and 150 Ω) trending patterns can be established. Periodically run the IDR check to verify proper operation of the ST100 electronics package. Use the IDR check as a troubleshooting tool to isolate a fault between the sensor and the electronics.

Running the Internal Delta-R Resistor Check

There are two ways to run the Internal Delta-R Resistor Check.

Using the HMI:

Hold the "Hot Key" (top sensor) for three seconds. Select "Diagnostics." Select "Self Test." Select "FE 1 IDR" (or FE 2 IDR if present) and enter the User Level Password (E#C). See Appendix C, page 78 for the IDR display sequence.

The IDR routine runs and the resulting values are shown on the HMI. These values are not saved and must be recorded by hand if required.

When a scheduled Internal Delta-R Check is running the HMI shows the Fault icon (exclamation point inside a triangle) displayed above the flow rate. If the IDR check is triggered via the HMI, the message *FE 1 IDR Test in Progress* is shown. Data from an HMI-initiated IDR check is not saved. IDR data can only be saved to the microSD card via the PC configuration application's **Scheduled Tests** tab (Diagnostics).

Using the ST100 Configuration Software Application:

Click **USB Connect** on the home screen. Select the *Diagnostics* branch from the menu tree on the window's left side. Select the **Scheduled Tests** tab. Select the "FE #" desired from the drop-down list.

Select desired **Mode** via the drop-down list. The check can be run on a Day of Month (1-28), Every Nth Day (1-255), Day of Week (0=Sun), Every Day. Use the **Day, #days, DOW** spinner control to define the Mode selection above. Use the **Time** spinner control to enter the desired time of the scheduled check. Alternatively, click **Run Check Now** to run the IDR check on demand.

After clicking **Run Check Now** a dialog box displays the expected and the measured resistance values. These instant checks are not logged to the FRAM and not displayed under the **Test Logs** tab as the Scheduled Tests files. Furthermore, they cannot be added to the SD card logs.

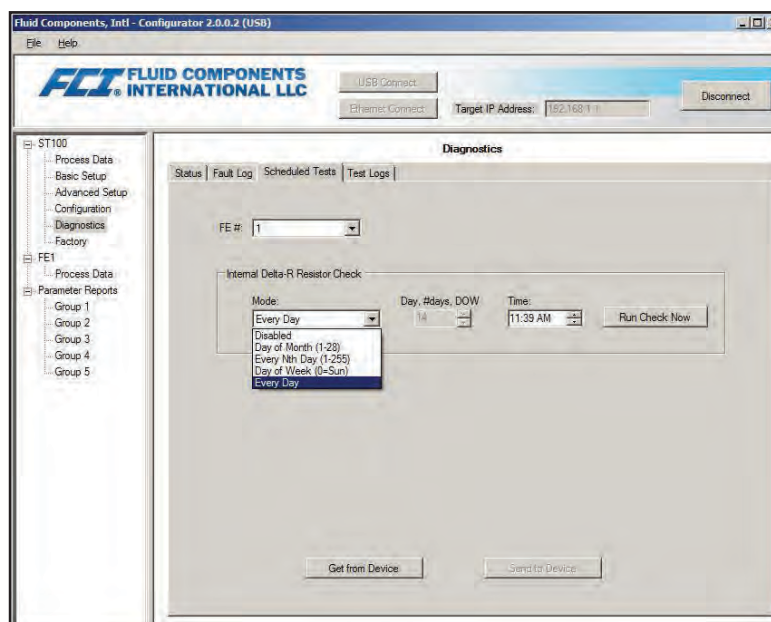

Internal Delta R Scheduled Tests Setup

The Internal Delta-R Resistor Check may be programmed ahead of time using the ST100 configuration software application. The user may run and save a Test Log (to the ST100 internal FRAM) automatically at these user-defined intervals:

- Day of Month (1-28)
- Every Nth Day (1-255)
- Day of Week (0=Sun)
- Every Day

To run the check immediately on demand click **Run Check Now**.

IDR files are viewed in the "Test Logs" tab. These files may be added to the microSD card for further analysis by selecting the "Add to SD Card Logs." The SD Card must be manually removed to transfer these IDR log files to a PC. Use a card reader as described in "Remove microSD Card from the Instrument and Manually Transfer Files with a Card Reader" on page 24.

The IDR log file is always named "DLTRLOG" and is amended every time a new scheduled test is initiated. Process data log files are always a new file with a unique file name as shown.

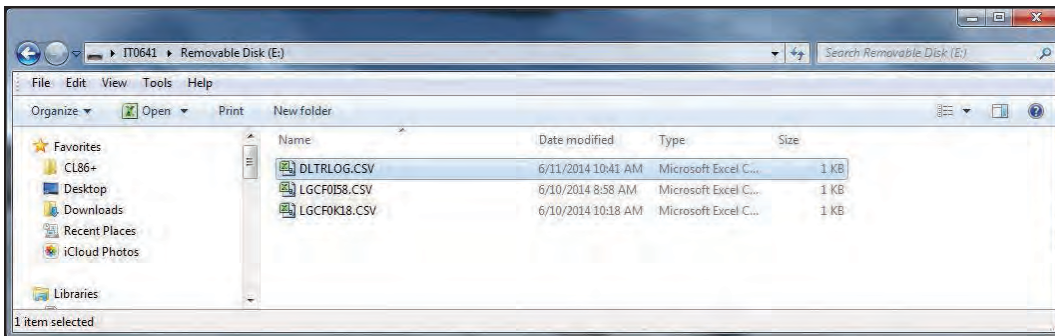

IDR Log and Process Data Log Files on microSD Card Example

Year	Month	Day	Time	FE	Act Ohms	Exp Ohms	Act Ohms	Exp Ohms	Act Ohms	Exp Ohms
2014	5	6	10:21:24	0	59.96	60	99.76	100	149.78	150
2014	5	8	10:21:24	0	59.96	60	99.76	100	149.76	150
2014	5	12	10:21:24	0	59.94	60	99.75	100	149.76	150
2014	5	13	14:52:24	0	59.95	60	99.76	100	149.77	150
2014	6	11	10:41:24	0	59.95	60	99.76	100	149.76	150
2014	6	11	11:39:24	0	59.95	60	99.75	100	149.78	150

Internal Delta-R Log File Results Example (Data Formatted and Titles Added using Microsoft Excel)

Analog Output Response to IDR Check

During the IDR sequence the analog outputs respond as listed below. Readings are taken with a 250 Ω load across Analog Output 1, 2 or 3.

NAMUR Enabled LOW

2.325 Vdc = 23.16 sfps = baseline (example: actual flow output varies from 1-5 volts)

0.900 Vdc = IDR In Progress

1.000 Vdc = momentary state

2.326 Vdc = after 3 seconds. IDR values are displayed now.

NAMUR Enabled HIGH

2.325 Vdc = 23.16 sfps = baseline (example: actual flow output varies from 1-5 volts)

5.250 Vdc = IDR In Progress

1.000 Vdc = momentary state

2.326 Vdc = after 3 seconds. IDR values are displayed now.

NAMUR Enabled Disabled

2.325 Vdc = 23.16 sfps = baseline (example: actual flow output varies from 1-5 volts)

1.000 Vdc = IDR In Progress

2.326 Vdc = after 3 seconds. IDR values are displayed now.

Extended Operation Modes

The measurement capabilities of the ST100 series instruments are expanded with the following extended operating modes:

- External Input Flow Adjust (EIA)
- External ST100 Flow Input (EFI)
- Auto FE Calibration Group Switching (FCS)
- External Control Group Switching (EGS)

Use the ST100 configuration software application to set up an extended operating mode. The ST100 HMI menu cannot be used to program this feature.

Basic

This is the factory default mode of operation (no extended operating mode in effect).

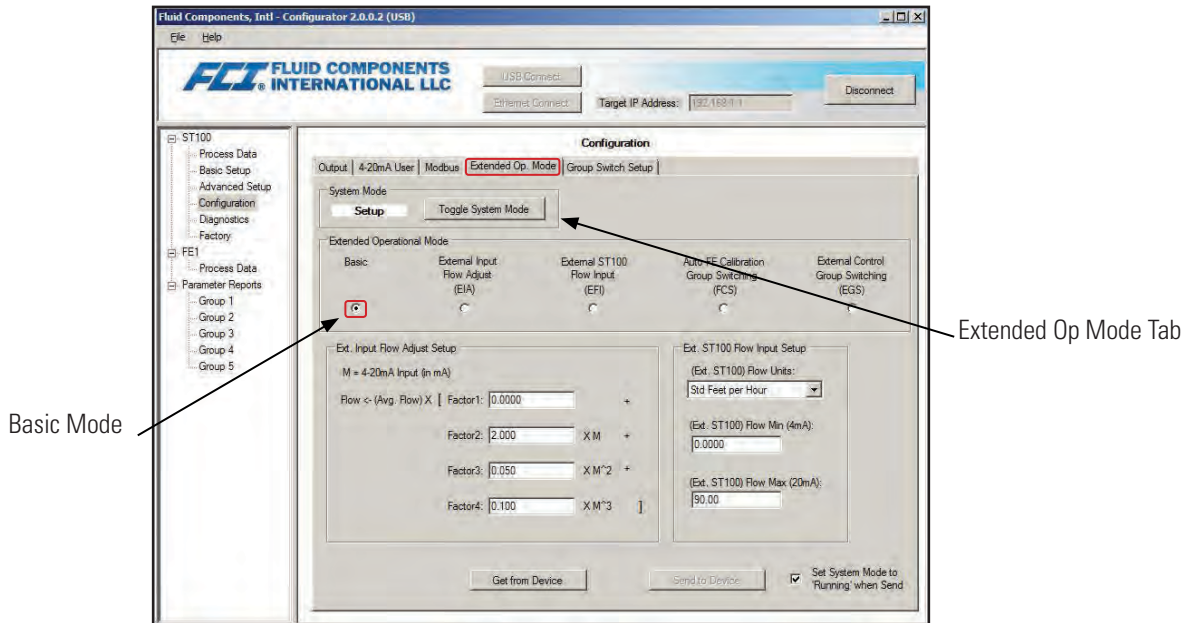

Extended Modes Select Screen

External Input Flow Adjust (EIA)

This mode corrects the flow rate of an ST100 flow meter when an external 4-20 mA current is fed into the Auxiliary Input port. Four polynomial factors are used to determine the correction applied to the flow rate and corresponding 4-20 mA output. The equation that defines this correction is as follows:

$$\text{Corrected Flow Rate} = (\text{Starting Flow Rate} \times \text{Factor1}) + (\text{Factor2} \times 4\text{-}20 \text{ mA Input}) + (\text{Factor3} \times 4\text{-}20 \text{ mA Input}^2) + (\text{Factor4} \times 4\text{-}20 \text{ mA Input}^3)$$

Make all necessary connections as shown in the wiring diagram in Figure B-19.

Start the application. Click **USB Connect** on the home screen. Select the *Configuration* branch from the menu tree on the window's left side. Select the **Extended Op. Mode** tab. Click **Toggle System Mode**. Enter user level password 2772 at the prompt. Verify instrument is in the service state with *Setup* showing in *System Mode* field. Click **External Input Flow Adjust (EIA)** radio button. In the window's *Ext. Input Flow Adjust Setup* field enter the four polynomial factors in the text box for *Factor1*, *Factor2*, *Factor3*, and *Factor4*.

At window bottom click *Set System Mode to 'Running' when Send* check box. Click **Send to Device** near check box to send the EIA programming to the instrument. Observe return to normal operation with *Running* showing in *System Mode* field.

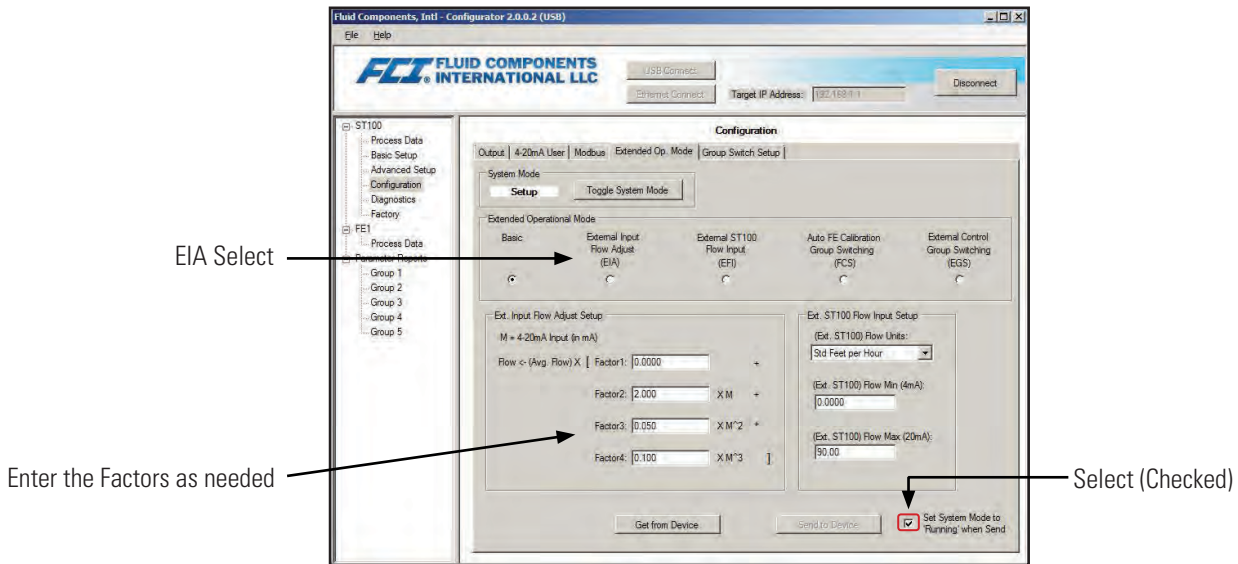

External 4-20 mA Correction Input Screen

The Process Data screen on the ST100 configuration application will now display "EXTENDED OP MODE EIA" in the upper left corner. The HMI display also shows **EIA** on the Group Number line after the HMI is refreshed. Refresh the HMI display by cycling the power to the unit or covering the Hot Key for 3 seconds.

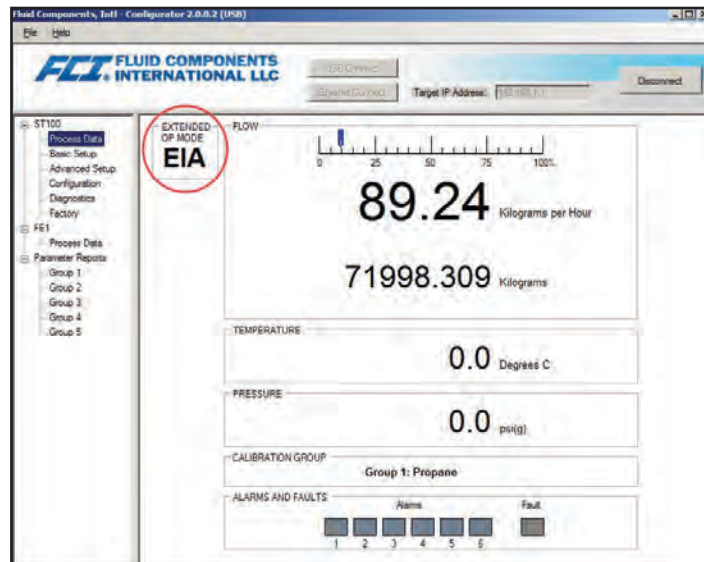

Example Process Data Screen with EIA Mode Shown

External ST100 Flow Input (EFI)

This mode connects two separate ST100 flow meters for continuous flow averaging. This is done by sending 4-20 mA output current (relative to flow rate) from one ST100 (Slave) to the Auxiliary Input port of the other ST100 (Master). In this manner the Master displays the average flow rate and corresponding 4-20 mA output current.

Make all necessary connections as shown in the wiring diagram in Figure B-20.

Start the application. Click **USB Connect** on the home screen. Select the *Configuration* branch from the menu tree on the window's left side. Select the **Extended Op. Mode** tab. Click **Toggle System Mode**. Enter user level password 2772 at the prompt. Verify that instrument is in the service state with *Setup* showing in the *System Mode* field. Click **External ST100 Flow Input (EFI)** radio button. In the window's *Ext. ST100 Flow Input Setup* field, select the Slave ST100 flow units from the drop-down list. Enter the flow rate equal to 4 mA into the (*Ext. ST100 Flow Min (4mA)*) text box. Enter the flow rate equal to 20 mA into the (*Ext. ST100 Flow Max (20mA)*) text box.

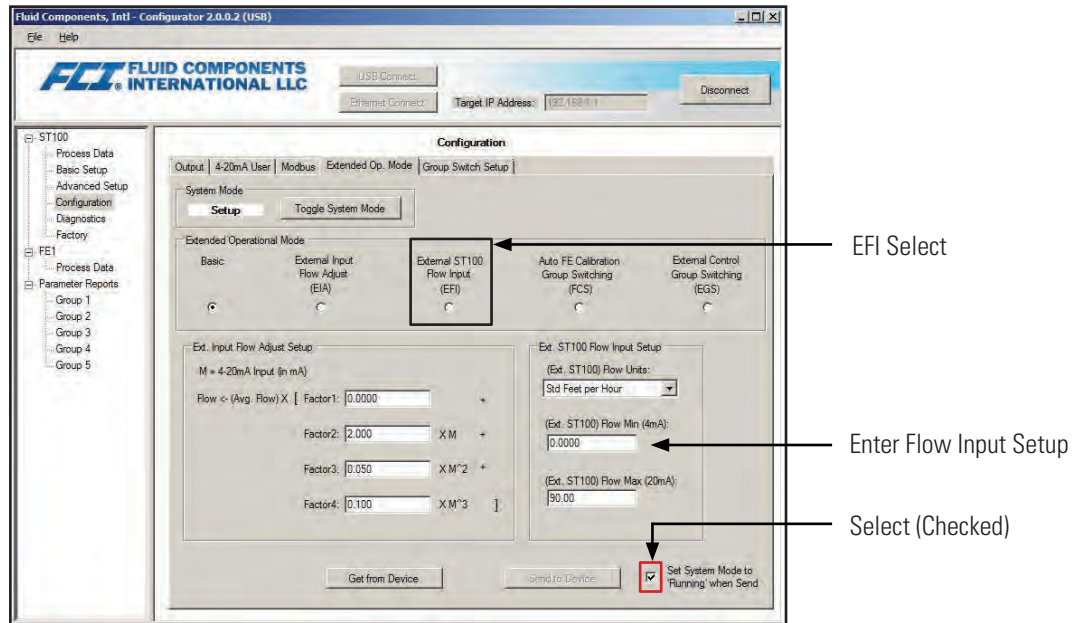

External 4-20 mA Input Setup Screen

At window bottom click *Set System Mode to 'Running' when Send* check box. Click **Send to Device** near check box to send the EFI programming to the instrument. Observe return to normal operation with *Running* showing in *System Mode* field.

The Process Data screen on the ST100 configuration application will now display "EXTENDED OP MODE EFI" in the upper left corner. The HMI display also shows **EFI** on the Group Number line after the HMI is refreshed. Refresh the HMI display by cycling the power to the unit or covering the Hot Key for 3 seconds.

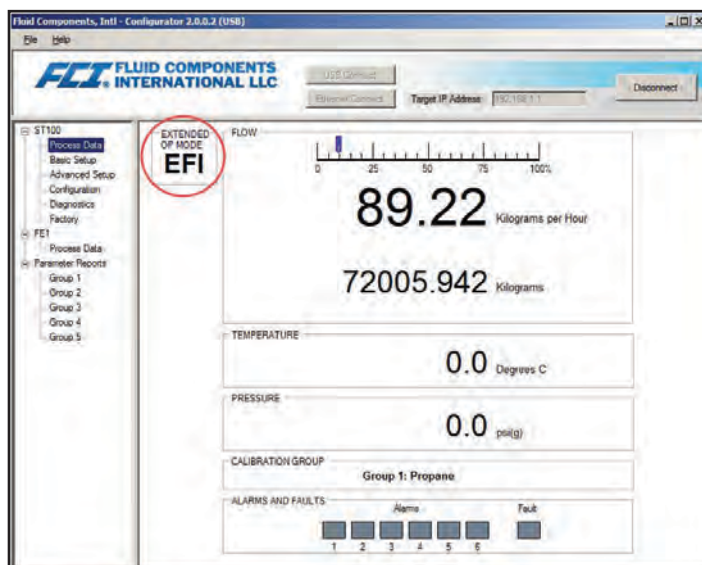

Example Process Data Screen with EFI Mode Shown

Auto FE Calibration Group Switching (FCS)

This mode automatically changes the ST100 calibration group based on specific process data values of flow rate, temperature, or pressure (in FCI Units). Start the application. Click **USB Connect** on the home screen. Select the *Configuration* branch from the menu tree on the window's left side. Select the **Extended Op. Mode** tab. Click **Toggle System Mode**. Enter user level password 2772 at the prompt. Verify that instrument is in the service state with *Setup* showing in *System Mode* field. Click **Auto FE Calibration Group Switching (FCS)** radio button.

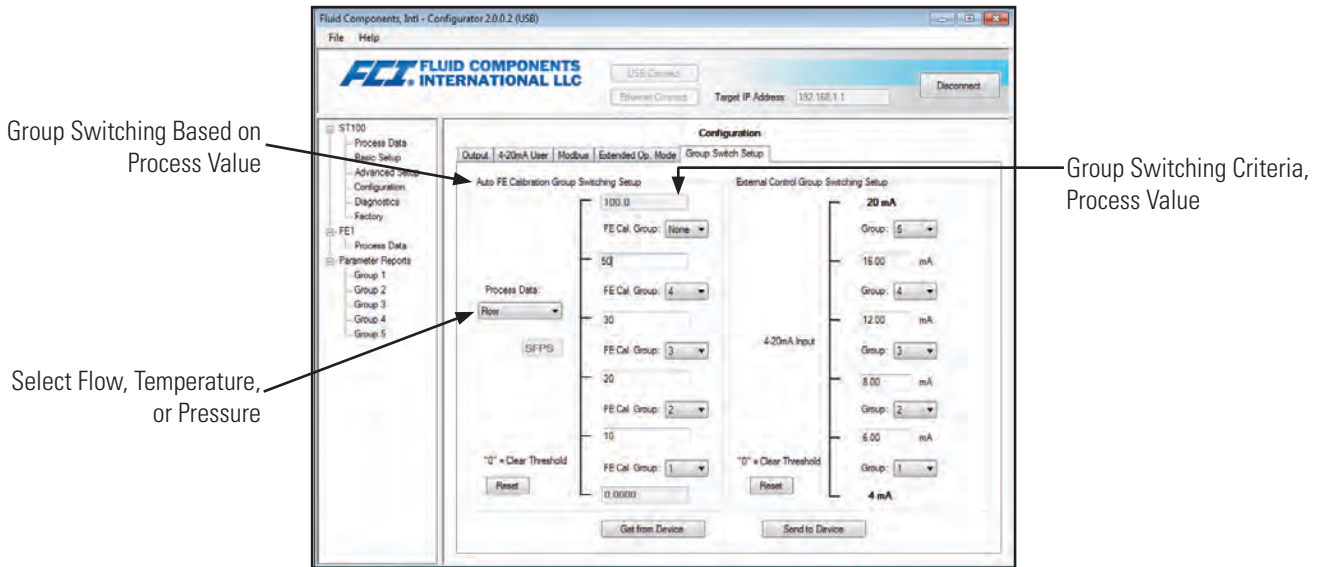

Auto FE Calibration Group Switching (FCS) Setup

Select the **Group Switch Setup** tab. In the window's *Auto FE Calibration Group Switching Setup* field, specify the process data type via the *Process Data* drop-down list (choose from *Flow*, *Temperature*, or *Pressure*). Observe that the corresponding engineering units are shown below the *Process Data* selection. The application then automatically defines the range over which group switching occurs by populating the bottom and top process data value text boxes with the calibrated MIN and MAX values respectively. Enter one or more process data values as required for the application. Assign an FE calibration group to a process data value entry by selecting its number from the *FE Cal. Group* drop-down list. A process data entry without a calibration group assignment assumes the last switched calibration group. The FCS setup field's **Reset** button provides a quick way to set process data to *Flow* (with calibrated MIN and MAX values entered into the bottom and top process data value text boxes).

Click **Send to Device** to send the FCS programming to the instrument. Return to normal operation by selecting the **Extended Op. Mode** tab and clicking **Toggle System Mode** (observe that *System Mode* field shows *Running*).

The Process Data screen on the ST100 configuration application will now display "EXTENDED OP MODE FCS" in the upper left corner. The HMI display also shows **FCS** on the Group Number line after the HMI is refreshed. Refresh the HMI display by cycling the power to the unit or covering the Hot Key for 3 seconds.

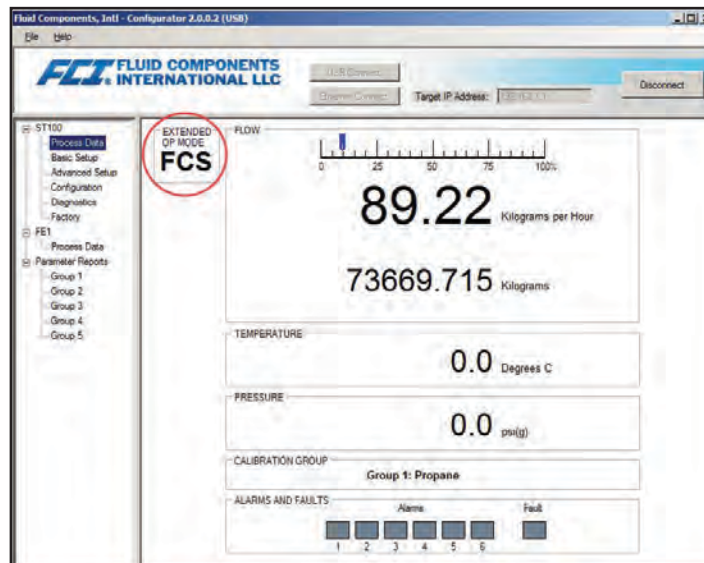

Example Process Data Screen with FCS Mode Shown

External Control Group Switching (EGS)

This mode automatically changes the ST100 calibration group based on a 4-20 mA output current from another device fed into the ST100 Auxiliary Input port.

Start the application. Click **USB Connect** on the home screen. Select the *Configuration* branch from the menu tree on the window's left side. Select the **Extended Op. Mode** tab. Click **Toggle System Mode**. Enter user level password 2772 at the prompt. Verify that instrument is in the service state with *Setup* showing in *System Mode* field. Click **External Control Group Switching (EGS)** radio button.

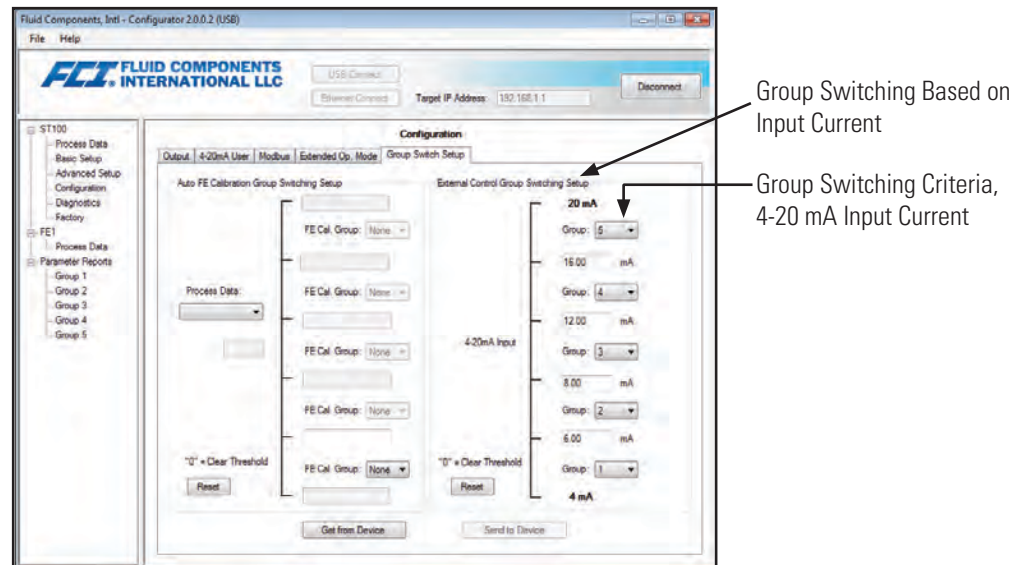

External Control Group Switching (EGS) Setup

Select the **Group Switch Setup** tab. In the window's *External Control Group Switching Setup* field, specify a 4-20 mA input value in the text box and its calibration group assignment via the associated *Group* drop-down list (define up to 5 points starting with the lowest value at the bottom). These entries determine which calibration group is active as the auxiliary input current varies. The EGS setup field's **Reset** button provides a quick way to clear out all programming entries (mA value/calibration group assignment).

Click **Send to Device** to send the EGS programming to the instrument. Return to normal operation by selecting the **Extended Op. Mode** tab and clicking the **Toggle System Mode** button (observe that *System Mode* field shows *Running*).

The Process Data screen on the ST100 configuration application will now display "EXTENDED OP MODE EGS" in the upper left corner. The HMI display also shows **EGS** on the Group Number line after the HMI is refreshed. Refresh the HMI display by cycling the power to the unit or covering the Hot Key for 3 seconds.

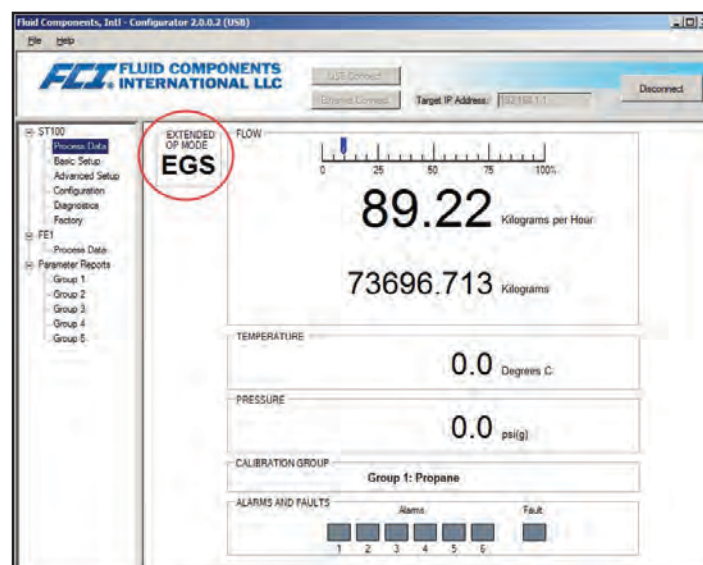

Example Process Data Screen with EGS Mode Shown

Intentionally Left Blank

4 MAINTENANCE

Warning: To avoid hazards to personnel, ensure that all environmental isolation seals are properly maintained.

Caution: The electronics contains electrostatic discharge (ESD) sensitive devices. Use standard ESD precautions when handling the electronics. Refer to "ESD Precautions" on page 13.

The FCI instrument requires little maintenance. There are no moving parts or mechanical parts subject to wear in the instrument. The sensor assembly which is exposed to the process media is all stainless steel construction.

Without detailed knowledge of the environmental parameters of the application surroundings and process media, FCI cannot make specific recommendations for the periodic inspection, cleaning, or testing procedures. However, some suggested general guidelines for maintenance steps are offered below. Use operation experience to establish the frequency of each type of maintenance.

Calibration

Periodically verify the calibration of the output and recalibrate if necessary. See Chapter 4: Troubleshooting. FCI recommends every 18 months at a minimum.

Electrical Connections

Periodically inspect cable connection on terminal strips and terminal blocks. Verify that terminal connections are tight and physically sound with no signs of corrosion

Remote Enclosure

Verify that the moisture barriers and seal protection of the electronics, in the local and remote enclosures, are adequate and that no moisture is entering those enclosures.

Electrical Wiring

FCI recommends occasional inspection of the system's interconnecting cable, power wiring and flow element wiring on a "common sense" basis as appropriate to the application environment. Periodically inspect the conductors for corrosion and the cable insulation for signs of deterioration.

Flow Element Connections

Verify that all seals are performing properly and that there is no leakage of the process media. Check for deterioration of the gaskets and environmental seals used.

Flow Element Assembly

Periodically remove the flow element for inspection based on historical evidence of debris, foreign matter, or scale build-up and appropriate plant shutdown schedules and procedures. Check for corrosion, stress cracking, and/or build-up of oxides, salts, or foreign substances. The thermowells must be free of excessive contaminants and be physically intact. Any debris or residue build-up could cause inaccurate flow measurement. Clean the flow element, as necessary, with a soft brush and available solvents (compatible with stainless steel).

Intentionally Left Blank

5 TROUBLESHOOTING

Warning: Testing/troubleshooting of this instrument is limited to qualified personnel only. The operator assumes all responsibilities or safe practices while troubleshooting.

Caution: The electronics contains electrostatic discharge (ESD) sensitive devices. Use standard ESD precautions when handling the electronics. Refer to "ESD Precautions" on page 13.

In new or re-calibrated instruments, operating problems are most often caused by an improper installation. Review the information on instrument installation in Section 2 starting on page 7. Verify the correct mechanical and electrical installation.

Troubleshooting is more effective if the operation of the equipment is understood before trying to solve the equipment problems. Be familiar with the way the instrument operates before troubleshooting an instrument that does not function properly.

Replacement parts must be of the same part type and number. Contact the FCI customer service department for the correct replacement parts.

Damage to equipment due to negligence or lack of technical skill is not covered by the warranty. When parts are replaced, the verification and calibration procedures must be performed by a qualified technician to ensure the accuracy and calibration of the instrument.

Quick Check

- Verify the serial numbers of the flow element and electronics match.
- Verify all cables are seated firmly.
- Verify all customer connections are correct.
- Verify the wiring is per the correct wiring diagram(s).
- Verify the installation is correct as shown in Installation section.
- Check customer fuses and power switches.
- Verify normal display on the HMI (flow rate, temperature, group number, group name, etc.)

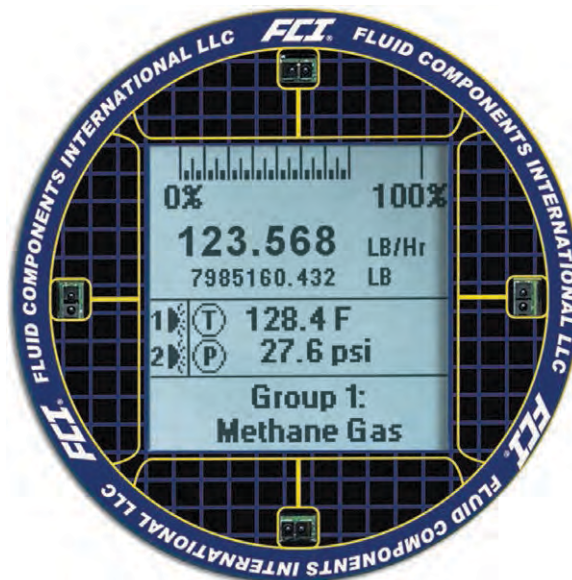

- Confirm that the display indicates the correct calibration group name as stated on the dR sheet.
- Confirm the display's fault status indication.
- If the Fault Alarm sign is continuously on it indicates an instrument fault. Troubleshoot the instrument as described in this section.

General Function Check

The ST100 series thermal mass flow meter is available in various configurations; this troubleshooting section covers ST100 Single point remote Analog (4-20mA/HART) ST100 Single point remote Digital bus output.

Tools Needed

- Digital Multimeter (DMM)
- ST100 Configuration Software Application
- USB Cable Standard Type A/Standard Type A (MM)
- Two Decade Resistance Boxes with resolution from 0.01 to 9999.99 ohms
- Allen Wrench 1/16 inch
- Small size flat blade screwdriver (for sensor wiring connection)

Setup Verification

Connect the flow meter via USB to a computer or laptop running the ST100 configuration software supplied with the instrument. See the ST100 configuration software manual for details.

Confirm the setup of the flow meter going through the setup windows in the configurator. Verify that the displayed information matches the parameters printed on the dR sheet parameter table. Contact your local representative or FCI for instructions if setup doesn't match.

NAMUR Fault Indication

NAMUR NE43 is a German fault detection standard that lets the user know if there is a fault within the instrument by forcing the 4-20 mA output current outside the normal operating range of the instrument.

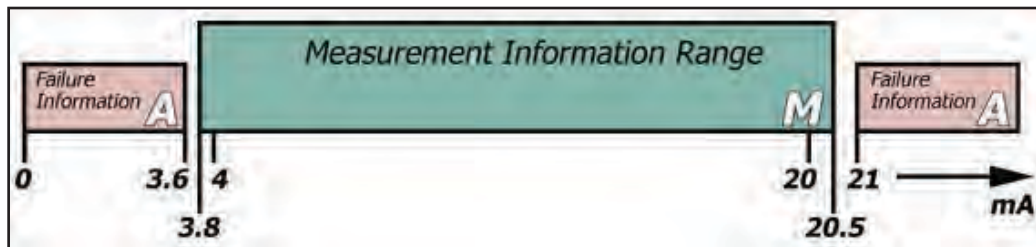

The NAMUR is turned on or off with the ST100 configuration software application only. The HMI cannot access NAMUR.

Click **USB Connect** on the home screen. Select the *Configuration* branch from the menu tree on the window's left side. Select the **4-20mA User** tab. Click on the **NAMUR Enabled** checkbox.

In the window's NAMUR field, define the NAMUR output level by clicking either **Set NAMUR @ 3.6 mA** or **Set NAMUR @ 21.0 mA**. Click **Send to Device** to save the settings to the instrument. To discard changes, exit the screen without clicking **Send to Device**.

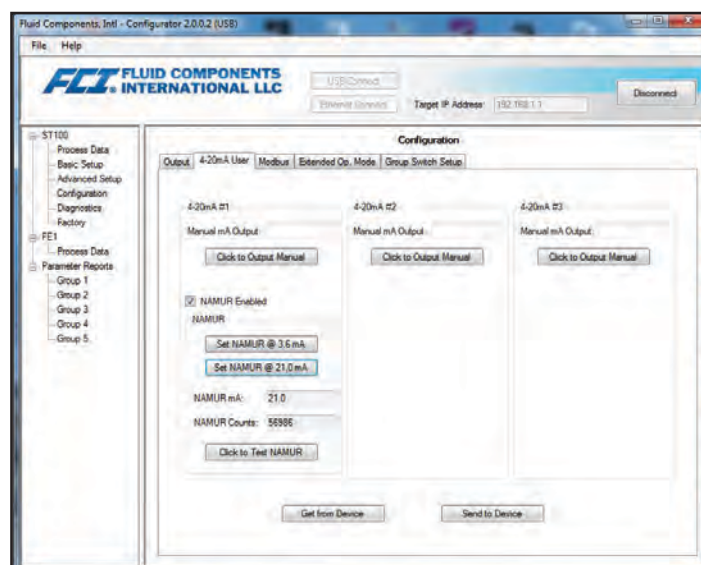

NAMUR Output Level Selection

When NAMUR is enabled, and a Fatal Fault is detected, the 4-20 mA output is forced to the preselected NAMUR output level. Use the **Click to Test NAMUR** button (forces NAMUR output) as needed to verify the system setup and wiring.

FAULT BIT	FATAL FAULT ERROR OR STATUS DESCRIPTIONS
1	CORE: any of these errors: I2C error, UART error, Mutex error or Watchdog Reset.
4	CORE: unable to update process data (PD_NO_FE_DATA). Unable to obtain/use data from any active FEs.
6	CORE: detects FRAM/SPI error.
14	CORE: unable to communicate with one or more Fes (PD_COMM_ERROR).
16	CORE: averaged flow out of range of "Flow Min" or "Flow Max."
20	CORE: averaged temperature above "Temperature Max."
21	CORE: averaged temperature above "Temperature Min."
22	(Any) FE reports SENSOR_HEATER_1_SHORTED_FAULT.
23	(Any) FE reports SENSOR_HEATER_2_SHORTED_FAULT.
24	(Any) FE reports SENSOR_HEATER_1_OPEN_FAULT.
25	(Any) FE reports SENSOR_HEATER_2_OPEN_FAULT.
33	(Any) FE reports AD5754_DAC_FAULT.
37	(Any) FE reports HTRS_FAULTS_ADC_FAULT.

Fatal Faults that Trigger NAMUR

Application Verification

Equipment Needed

- ST100 Calibration certificate
- dR certificate supplied with the flow meter

Check Serial Numbers

Verify that the serial number of the flow element and the flow transmitter electronics are the same. The flow element and the flow transmitter are a matched set and cannot be operated independently of each other.

Check the Instrument Installation

Review the correct mechanical and electrical installation. Verify that the flow element is mounted at least 20 diameters downstream and 10 diameters upstream from any bends or interference in the process pipe or duct.

Check for Moisture

Check for moisture on the flow transmitter. Moisture on the flow transmitter may cause intermittent operation. Check for moisture on the flow element. If a component of the process media is near its saturation temperature it may condense on the flow element. Place the flow element where the process media is well above the saturation temperature of any of the process gases.

Check Application Design Requirements

Application design problems may occur with first time application instruments, although the design can also be checked on instruments that have been in operation for some time. If the application design does not match field conditions, errors occur.

Review the application design with plant operation personnel and plant engineers. Ensure that plant equipment such as pressure and temperature instruments conform to the actual conditions. Verify operating temperature, operating pressure, line size, and gas medium.

Verify Standard Versus Actual Process Conditions

The flow meter measures the mass flow rate. The mass flow rate is the mass of the gas flowing through a pipe per time. Other flow meters, such as an orifice plate or a pitot tube, measure the volumetric flow rate. The volumetric flow rate is the volume of gas per time. If the readings displayed do not agree with another instrument, some calculations may be necessary before comparing them. To calculate the mass flow rate, the volumetric flow rate, pressure, and temperature at the point of measurement must be known. Use the following equation to calculate the mass flow rate (Standard Volumetric Flow rate) for the other instrument:

Equation

$$Q_s = Q_A \times \left[\frac{P_A}{T_A} \times \frac{T_S}{P_S} \right]$$

Where:

Q_A = Volumetric Flow

P_A = Actual Pressure

P_S = Standard Pressure

Q_S = Standard Volumetric Flow

T_A = Actual Temperature

T_S = Standard Temperature

PSIA and °R are used for pressure and temperature units.

For Metric use bar(a) and °K are used for pressure and temperature.

Example:

Q_A = Volumetric Flow = 1212.7 ACFM

P_A = Actual Pressure = 19.7 PSIA

P_S = Standard Pressure = 14.7 PSIA

Q_S = Standard Volumetric Flow = 1485 SCFM

T_A = Actual Temperature = 120°F (580°R)

T_S = Standard Temperature = 70°F (530°R)

For Metric:

P_S = Standard Pressure = 1.01325 bar(a)

T_S = Standard Temperature = 21.1°C (294.1°K)

$$\left(\frac{1212.7 \text{ ACFM}}{1} \right) \left(\frac{19.7 \text{ PSIA}}{580^\circ\text{R}} \right) \left(\frac{530^\circ\text{R}}{14.7 \text{ PSIA}} \right) = 1485 \text{ SCFM}$$

Check the Hardware

Equipment Required:

- Digital Multimeter (DMM)
- ST100 Configuration Application
- USB cable Standard Type A male connection on both ends.
- Two Decade Resistance Boxes with resolution from 0.01 to 9999.99 ohms
- Allen Wrench 1/16 inch
- Small size flat blade screwdriver (for sensor wiring connection)

Troubleshooting the Flow Element

This procedure is different depending on the instruments configuration, Integral or Remote.

Integral Configuration (Reference Figure 18 shown below.)

1. Turn off the input power to the instrument.
2. Remove the two M4 socket head screws securing the electronics into the enclosure. A third M4 socket head screw is used to ground the electronics assembly, this screw can remain in place and will prevent the electronics from falling out of the enclosure.
3. Slide the electronics assembly out of the enclosure until the Flow Element connector TB1 is accessible.
4. Note the location of the positive locking tab on the connector. Carefully remove the plug from the connector.
5. Orient the pin 1 as shown in the figure below. Using an ohmmeter with pin type probes, measure and record the ohm values between the pins identified in the Integral Flow Element Resistance Table.

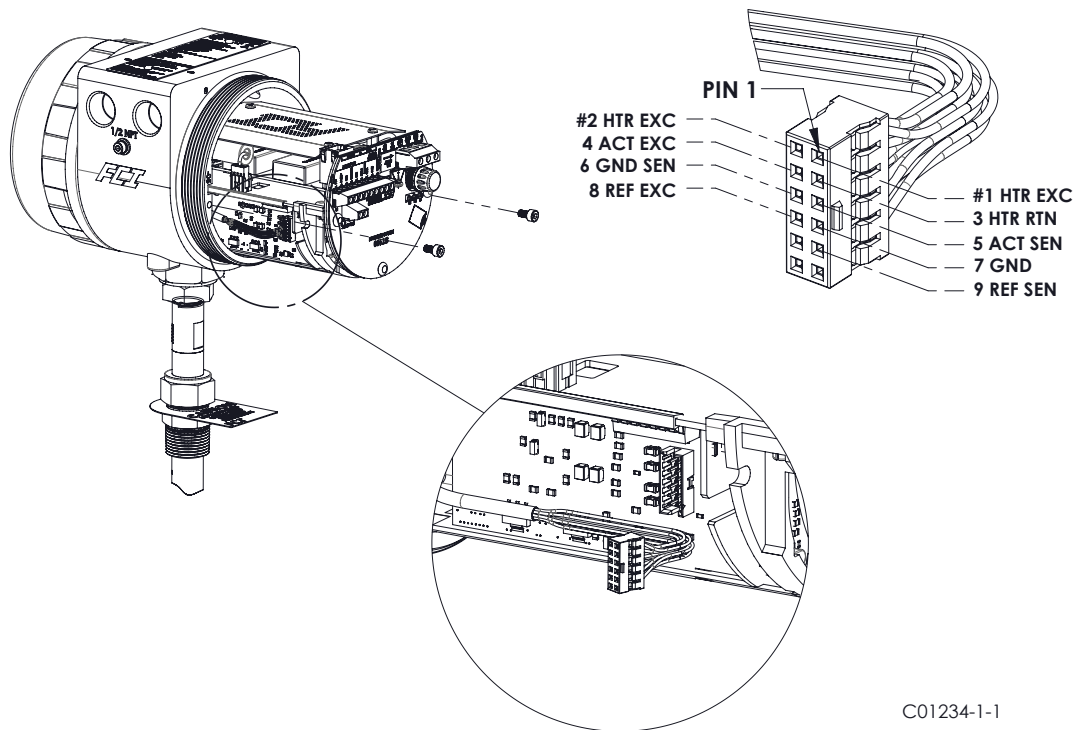

C01234-1-1

Figure 18

Probe A	Probe B	Approximate Resistance
1 HTR EXC	3 HTR RTN	110-118 ohms
4 ACT EXC	5 ACT SEN	0 ohms
8 REF EXC	9 REF SEN	0 ohms
9 REF SEN	5 ACT SEN	2160 ohms
6 GND SEN	4 ACT EXC	1080 ohms
6 GND SEN	5 ACT SEN	1080 ohms
6 GND SEN	8 REF EXC	1080 ohms
6 GND SEN	9 REF SEN	1080 ohms
6 GND SEN	7 GND	0 ohms

Integral Flow Element Resistance Table

The table values are temperature dependent and may differ several ohms higher or lower depending on the local temperature. The resistance values shown above are based on an ambient temperature of 70 °F (20 °C). If these resistance values are correct, the integral flow element is confirmed correct. If the resistance values are not correct there is a problem with the flow element.

6. Reassemble the flow element plug into the connector TB1 making sure the tab on the plug is in alignment with the tab on the connector.
7. Carefully slide the electronics assembly back into place, inside the enclosure, and secure with the two M4 socket head screws.

Remote Configuration (Reference Figure 19 shown below.)

1. Turn off the input power to the instrument.
2. Disconnect the flow element wires from local terminal block.
3. Using an ohmmeter, measure and record the ohm values between the pins identified in the Remote Flow Element Resistance Table.
4. Reassemble the flow element wires back onto the local terminal block as shown in the figure below.

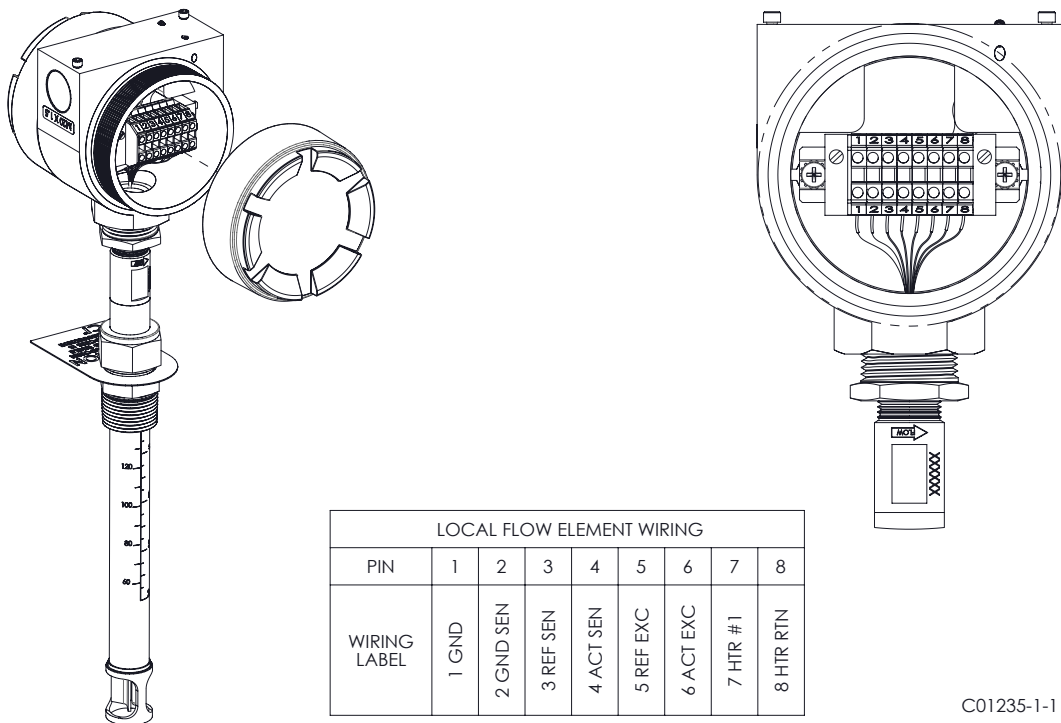

C01235-1-1

Figure 19

Probe A	Probe B	Approximate Resistance
1 GND	2 GND SEN	0 ohms
2 GND SEN	3 REF SEN	1080 ohms
2 GND SEN	5 REF EXC	1080 ohms
2 GND SEN	4 ACT SEN	1080ohms
2 GND SEN	6 ACT EXC	1080 ohms
3 REF SEN	4 ACT SEN	2160 ohms
3 REF SEN	5 REF EXC	0 ohms
4 ACT SEN	6 ACT EXC	0 ohms
8 HTR RTN	7 HTR EXC	110 -118 ohms

Remote Flow Element Resistance Table

The table values are temperature dependent and may differ several ohms higher or lower depending on the local temperature. The resistance values shown above are based on an ambient temperature of 70 °F (20 °C). If these resistance values are correct, the remote flow element is confirmed correct. If the resistance values are not correct there is a problem with the flow element.

- A similar resistance check can be made at the electronics side of the interconnecting cable. The interconnecting cable wires will add ohmic values depending on the cable wire size and length. The table below can be used to correct flow element measured values through the interconnecting cable by subtracting the cable resistance from the measured value.

AWG Size	Ohms Per 1000 Feet
14	2.52
15	3.18
16	4.02
17	5.05
18	6.39
19	8.05
20	10.1
21	12.8
22	16.2
23	20.3
24	25.7

Resistance Versus Wire Size (AWG)

Check the Flow Element Voltages

If resistance measurements fail to resolve the problem, or if power cannot be removed from the instrument, measure the following voltages. Using a DMM set to voltage, make the voltage measurements found in the table below at terminal strip P2A on the flow transmitter or on the sensor enclosure terminal block. Remote flow element cable resistance will affect the voltage readings at the electronics enclosure.

Wire	Expected Voltage*
HTR EXC to HTR RTN	≈ 6.79 VDC
ACT SEN to ACT EXC	≈ 0.00 VDC
REF SEN to REF EXC	≈ 0.00 VDC
REF EXC to GND	≈ 2.20 VDC
ACT EXC to GND	≈ 2.21 to 2.82 VDC**
ACT SEN to REF SEN	≈ 0.24 VDC**

Approximate Flow Element Voltages at 70 °F

*Voltages vary with temperature, flow rate, and the heater current.

**Voltages vary with the process flow rate.

Verification of the Electronics**Check the Flow Transmitter Power Supply Voltages**

Check the voltages shown in the table below with a DMM set to voltage. The readings are taken on the power supply board at connector P2.

Pin Number	Expected Power Supply Voltage
Digital 5 VDC: P1 to P2	4.975 to 5.025
Analog 24 VDC: P3 to P4	23.975 to 24.025

Instrument Power Supply Voltages

If the voltage checks correspond to the levels shown in the table, the power supply is functioning properly.

Transmitter Circuit Calibration Check (Delta R Verification)**Equipment Needed**

- FES-200 Flow Element Simulator with proper cable for FCI transmitter model
- Digital Multimeter
- Delta R Calibration Data Sheet (serial number specific by instrument and group)
- Precision 250 ohm resistor (recommended)

Alternate Tool for FES-200

- 2 - Precision Decade Resistance Box, 0.1% (1 k Ω large step, 0.01 Ω small step)

Note: If the flow meter's parameters have been changed, calibrations may be inaccurate or factory authorized changes have been made. Consult a factory service representative.

Each flow meter is provided with a Delta R data sheet which is a table listing the differential resistance values that correlate to the flow meter's calibration. Resistance substitution instruments like the FES-200 can be used to check instrument calibration and verify correct operation of the flow transmitter using the Delta R data sheet.

To verify the transmitter is working properly, the sensor head must be disconnected and precision resistance (Delta R) values from the FES-200 are substituted. Then by measuring the transmitter output and display it can be determined whether the transmitter is still within factory specification.

Safety Instructions

Warning: Explosion Hazard. Do not disconnect equipment when flammable or combustible atmosphere is present. Operator assumes responsibility for all safety concerns relating to interrupting and reapplying power to their instrumentation.

Delta R Check

1. Verify the Delta R data sheet has the same serial number and group number as the flow meter calibration that is being verified.
2. Power off the transmitter.
3. Disconnect the instrument's sensor and connect the FES-200 input connector into the transmitter. See Figures 22 – 24 for integral or remote configuration diagrams. Precision decade boxes can be used in place of the FES-200. See Figure 25 for decade box wiring.
4. Connect a DMM to the transmitter 4 – 20 mA output by either method A or B:
 - A. To read 1 to 5 volts, disconnect both output loop wires and connect a precision 250 Ω resistor across the output terminal (Figure 20). Then connect the DMM, set to DC volts (V), across the resistor to read the voltage drop.
 - B. To read 4 to 20 mA current, disconnect the output loop and connect the DMM, set to milliamps (mA), in series with the output circuit (Figure 21) to read the current flow.

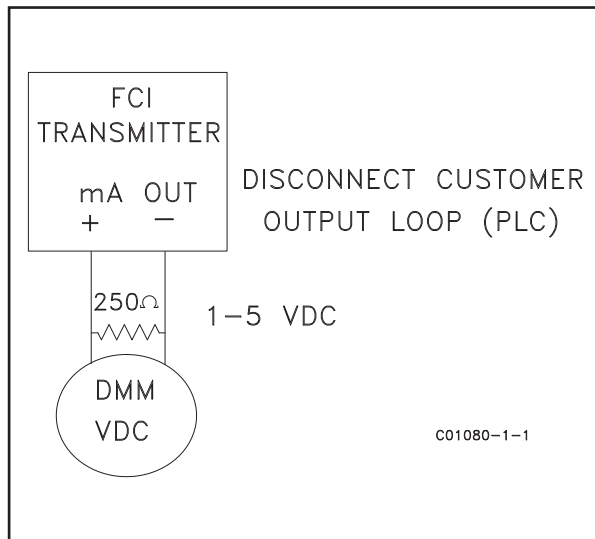

Figure 20

1-5 Volts, Connect DMM Across 250 Ω Resistor (A)

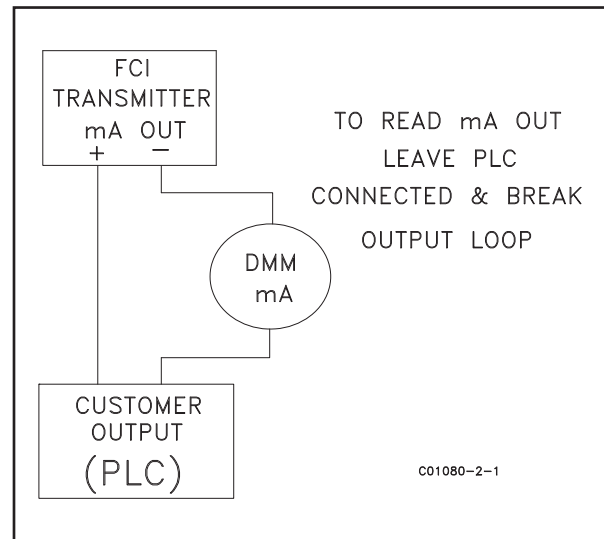

Figure 21

4-20 mA, Connect DMM in Series (B)

5. Turn power ON and allow the instrument 10 minutes to stabilize.
6. Verify the transmitter is in the calibration group matching the Delta R data sheet.
7. On the FES-200, dial in a Delta R value with the thumbwheel from the column marked Delta R (ohms) on the Delta R data sheet. Compare to the output value column (VDC Across 250 Ohms or mA Output) and/or the Indicated Display column. Verify that the meter reading is within the stated tolerance of the flow transmitter. See examples 1, 2 and 3 at the end of this section, as applicable.
8. Repeat for each point on the Delta R table, except for the step value and zero value.
9. Turn power OFF and disconnect the FES-200 and DMM. Reconnect the sensor element connector.
10. Close the enclosure, making sure none of the wires are strained. Ensure any seals and gaskets are properly installed.
11. Restore power to the meter.

If you are troubleshooting the flow meter and the readings are good, the flow transmitter is good and the problem may involve the flow element or interconnecting cable. If the readings are off, a flow element calibration may be required or the flow transmitter needs to be setup. Contact FCI Customer Service.

Heater Current Check

The heater current can be checked at TP1 on the FES-200. Set the DMM to measure VDC.

1. Connect the positive lead of the DMM to TP1 on the FES-200
2. Connect the negative lead of the DMM to the HTR EXC terminal of the flow transmitter.

The measured mV value of heater current will be 10x larger than the actual mA heater current. For example, 750 mV indicates 75 mA heater current. The measured value of heater current must be within ± 0.15 mA of the factory set value. See table below.

FCI Transmitter Model	Factory-set Heater Current	DMM Reading
ST100	90 mA	900 mV
ST100	75 mA	750 mV

Heater Current

Allowable Limits

Example 1 - 4-20 mA output check using 1-5 VDC measurement.

Accuracy: $\pm(0.75\% \text{ reading} + 0.5\% \text{ full scale})$ from GF90 Manual

Sample Delta R Table entry:

Delta 'R (ohms)	Vdc Across 250 ohms	mA Output	Unit dR	Indicated Display
71.08	2.995	11.98	71.197	154.8 SCFM

- Measure VDC with FES-200 thumbwheel set to 071.08 = 3.011 VDC measured on DMM
- Determine allowable VDC limits for the 2.995 VDC table value:

Note: Since the 1-5 VDC range starts at 1 VDC, account for this offset by subtracting 1 VDC from both the "reading" of 2.995 VDC and the "full scale" of 5 VDC.
- Allowable VDC limits = $0.0075 \times (2.995 - 1) + 0.005 \times (5 - 1) = \pm 0.035 \text{ VDC}$

The measured value of 3.011 VDC is within the allowable limits of 2.995 \pm 0.035 VDC

Example 2 - 4-20 mA output check (using example 1 sample data)

- Measure mA with FES-200 thumbwheel set to 071.08 = 12.04 mA measured on DMM
- Determine allowable mA limits for the 11.98 mA table value:

Note: Since the 4-20 mA range starts at 4 mA, account for this offset by subtracting 4 mA from both the "reading" of 11.98 mA and the "full scale" of 20 mA.
- Allowable mA limits = $0.0075 \times (11.98 - 4) + 0.005 \times (20 - 4) = \pm 0.139 \text{ mA}$

The measured value of 12.04 mA is within the allowable limits of 11.98 \pm 0.139 mA.

Example 3 - Indicated Display Check (using information from above examples)

- Record the indicated display value with FES-200 thumbwheel set to 071.08 = 156 SCFM indicated on display
- Determine allowable limits for the 154.8 SCFM table value:

Note: The full scale display value is 310 SCFM in this example.
- Allowable Indicated flow limits = $0.0075 \times 154.8 \text{ SCFM} + 0.005 \times 310 \text{ SCFM} = \pm 2.71 \text{ SCFM}$

The indicated value of 156 SCFM is within the allowable limits of 154.8 \pm 2.71 SCFM.

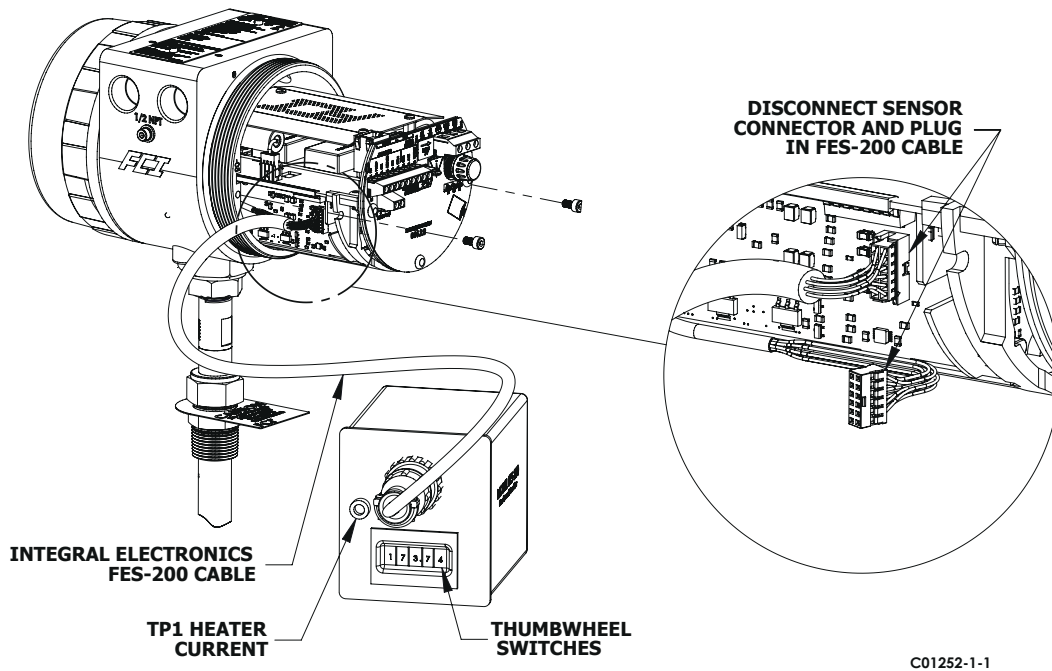

Figure 22 - Integral Configuration

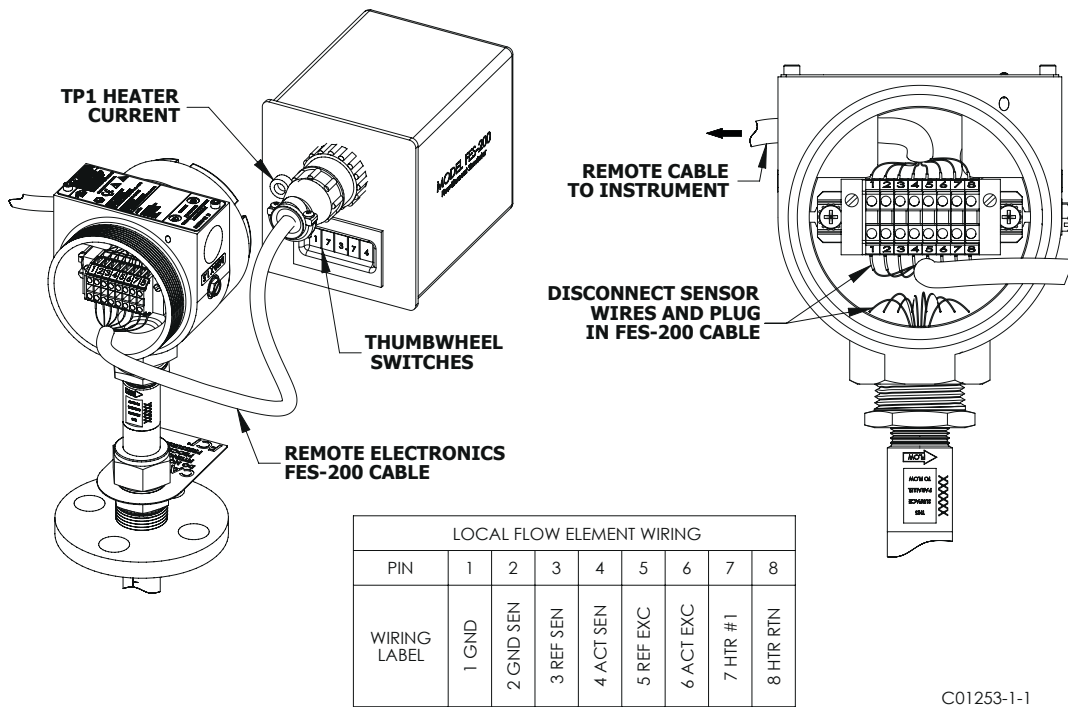

Figure 23 - Remote Configuration
FES-200 Connected at Flow Element

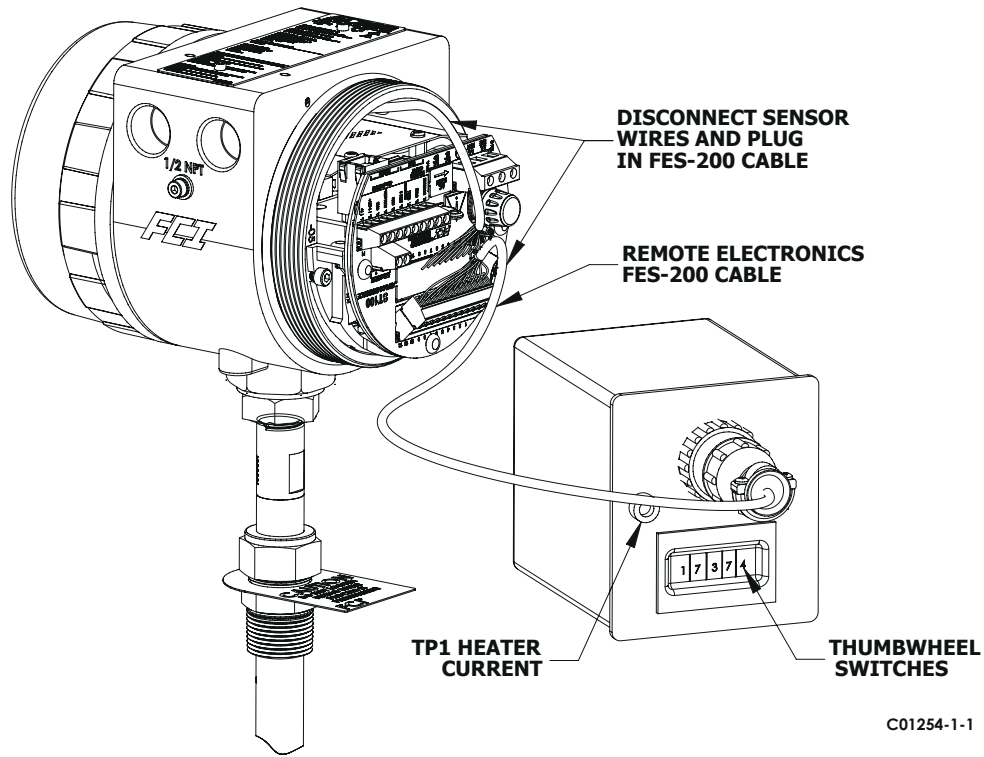
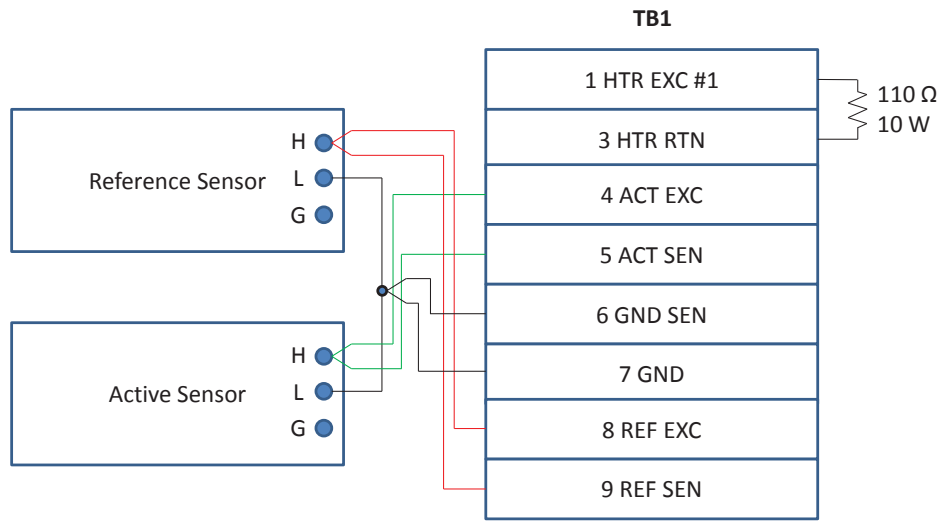

Figure 24 - Remote Configuration
FES-200 Connected at Electronics



C01255-1-1

Figure 25 - ST100 Decade Box Wiring

Output Verification using the ST100 Configuration Application

Another method for verifying the output current is by manually driving the output current via the ST100 configuration application. This allows the user to force the output to any given mA value between 4 and 20 mA.

Click **USB Connect** on the home screen. Select the *Configuration* branch from the menu tree on the window's left side. Select the **4-20mA User** tab. In the *4-20mA #1* frame, enter the desired mA output level in the **Manual mA Output** text box. Click **Send to Device**. The output is now driven to the desired level.

If the measured output levels match the expected output levels this proves the output circuit is working properly.

If the measured output levels do not match the expected output levels there is a problem with the system.

Defective Parts

Before returning any equipment to FCI, obtain an RA number for authorization, tracking and repair/replacement instructions. If a return is required, remove defective instrument, replace with spare, calibrate, and then return the defective instrument to FCI freight prepaid for disposition.

Intentionally Left Blank

APPENDIX A OUTLINE DIMENSIONAL DRAWINGS

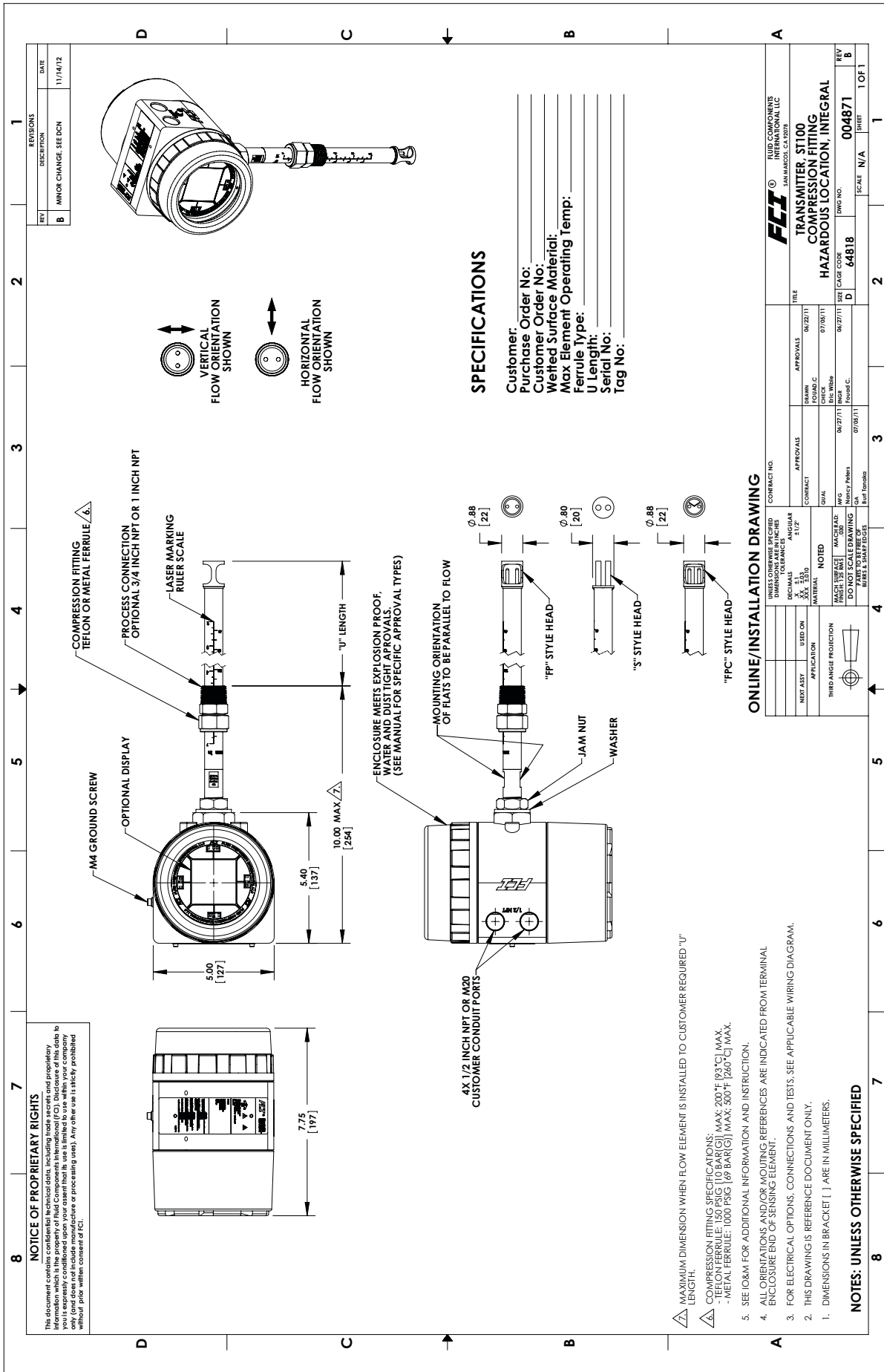

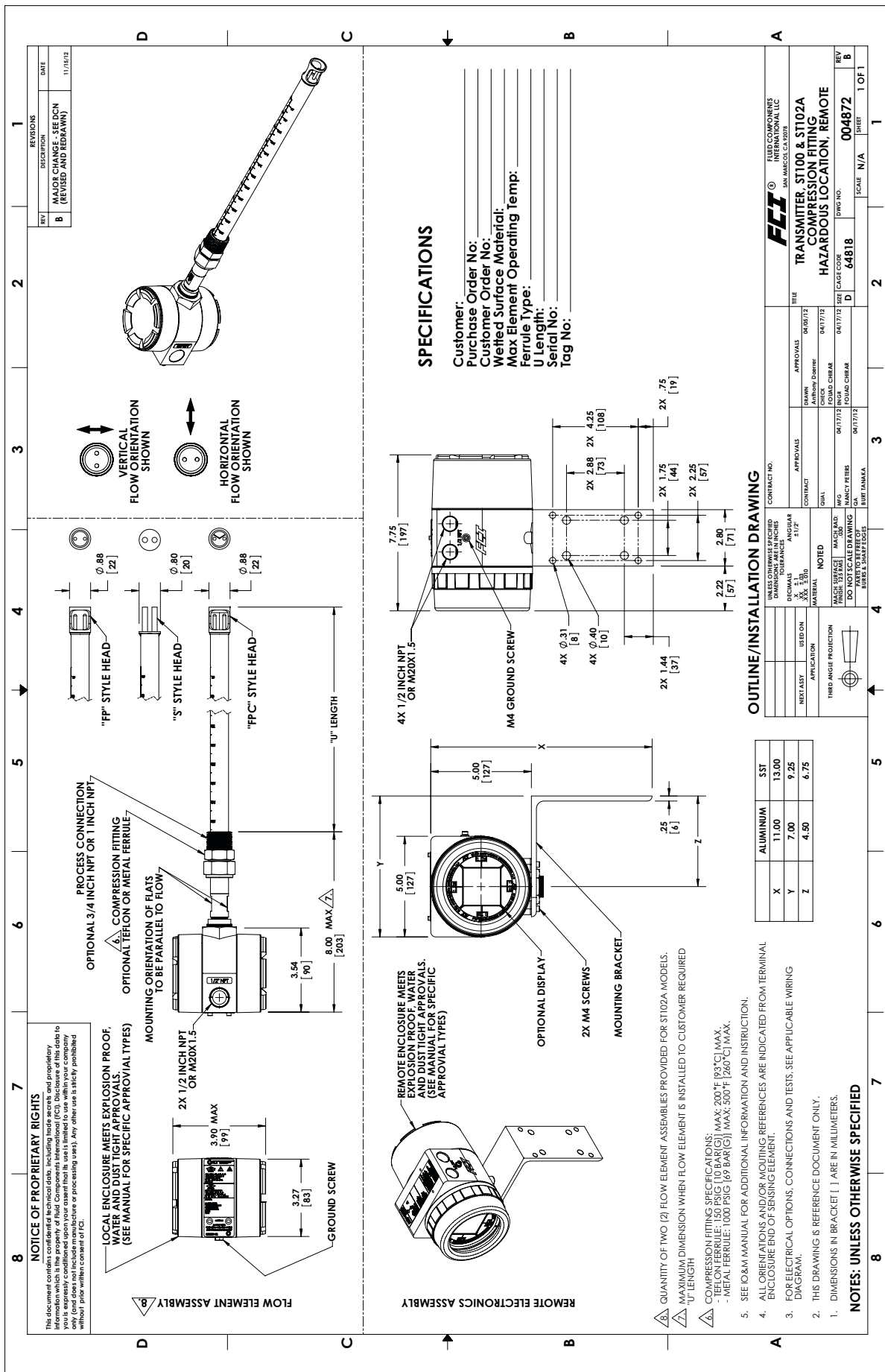

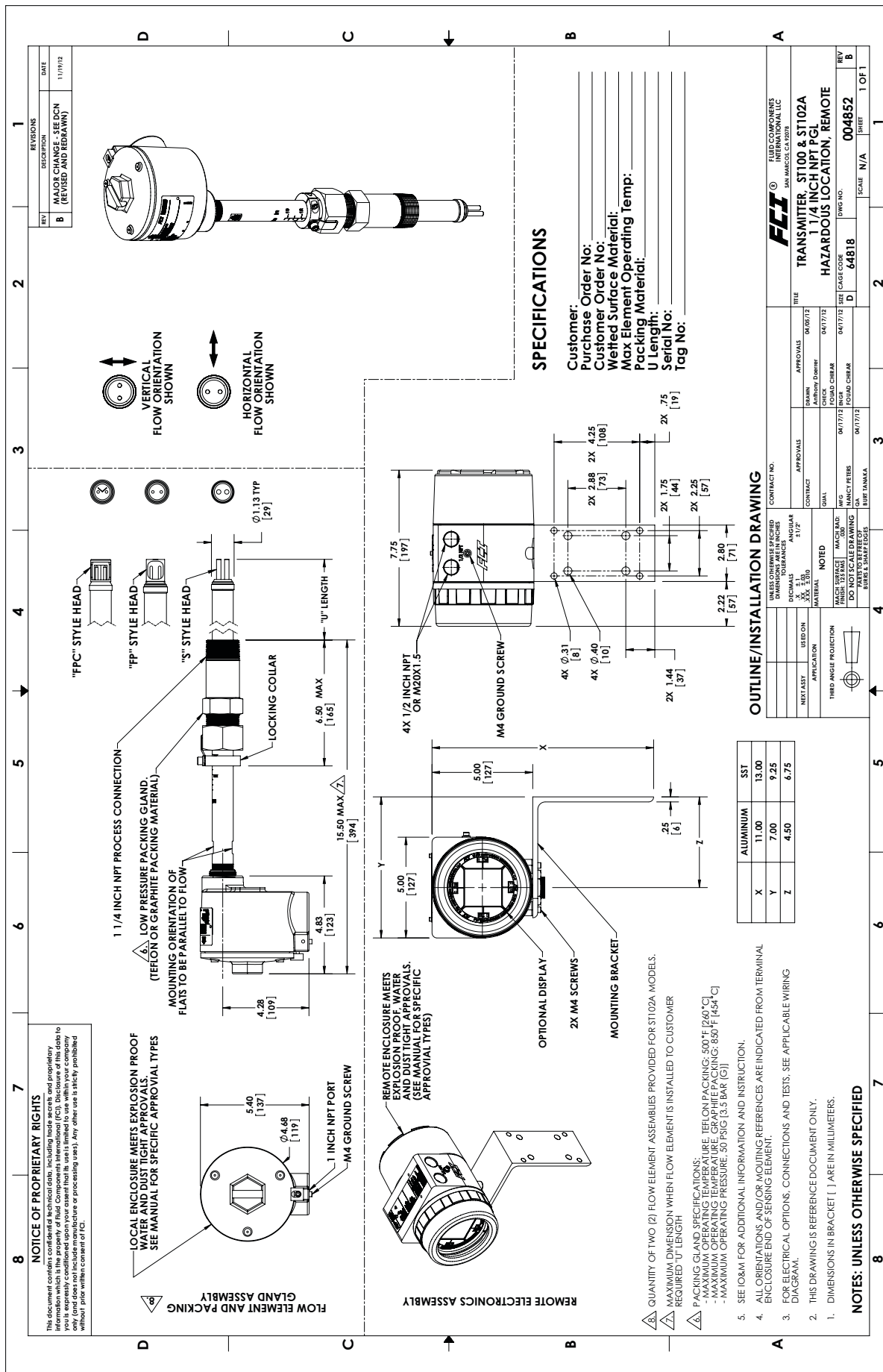

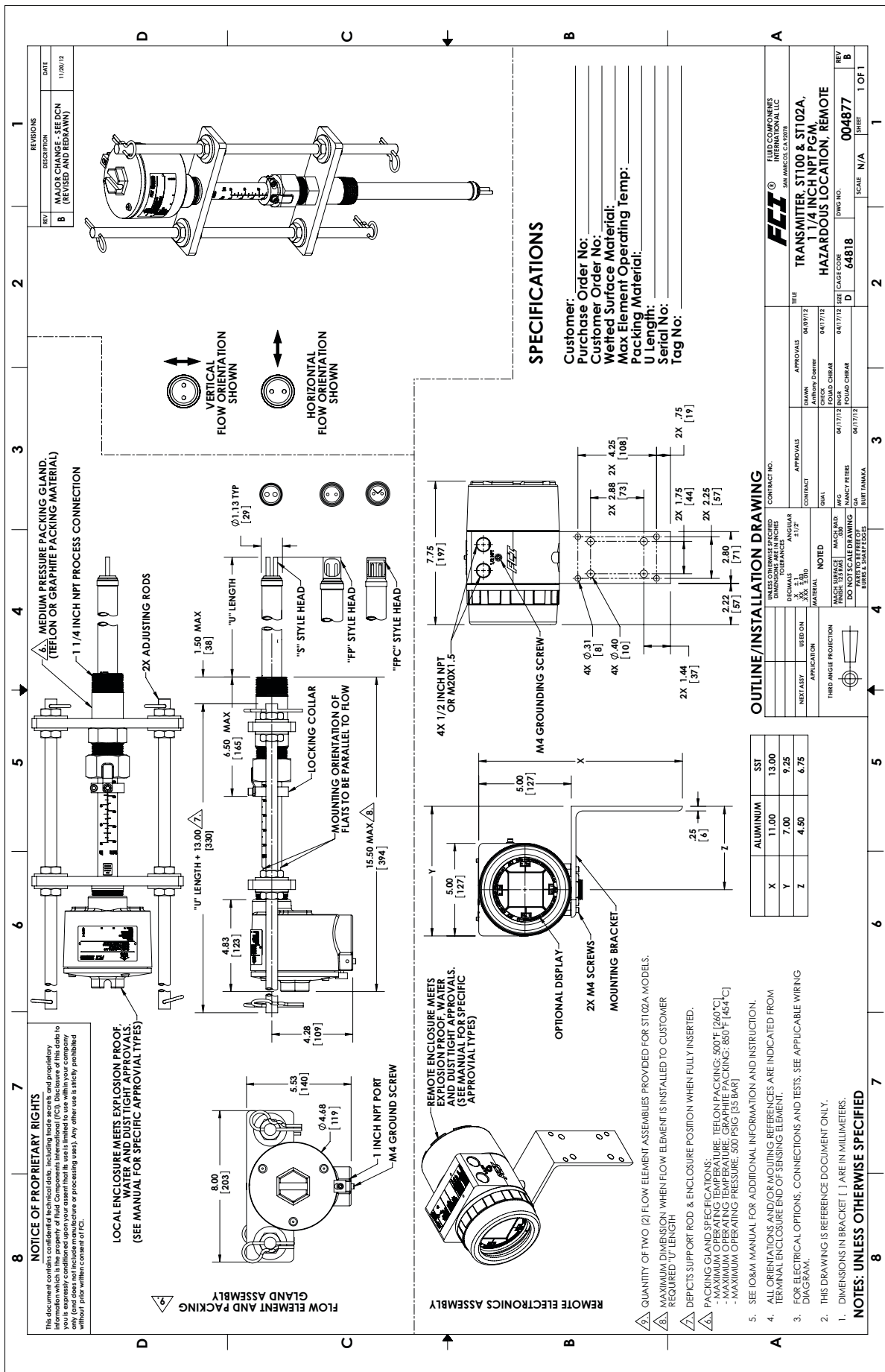

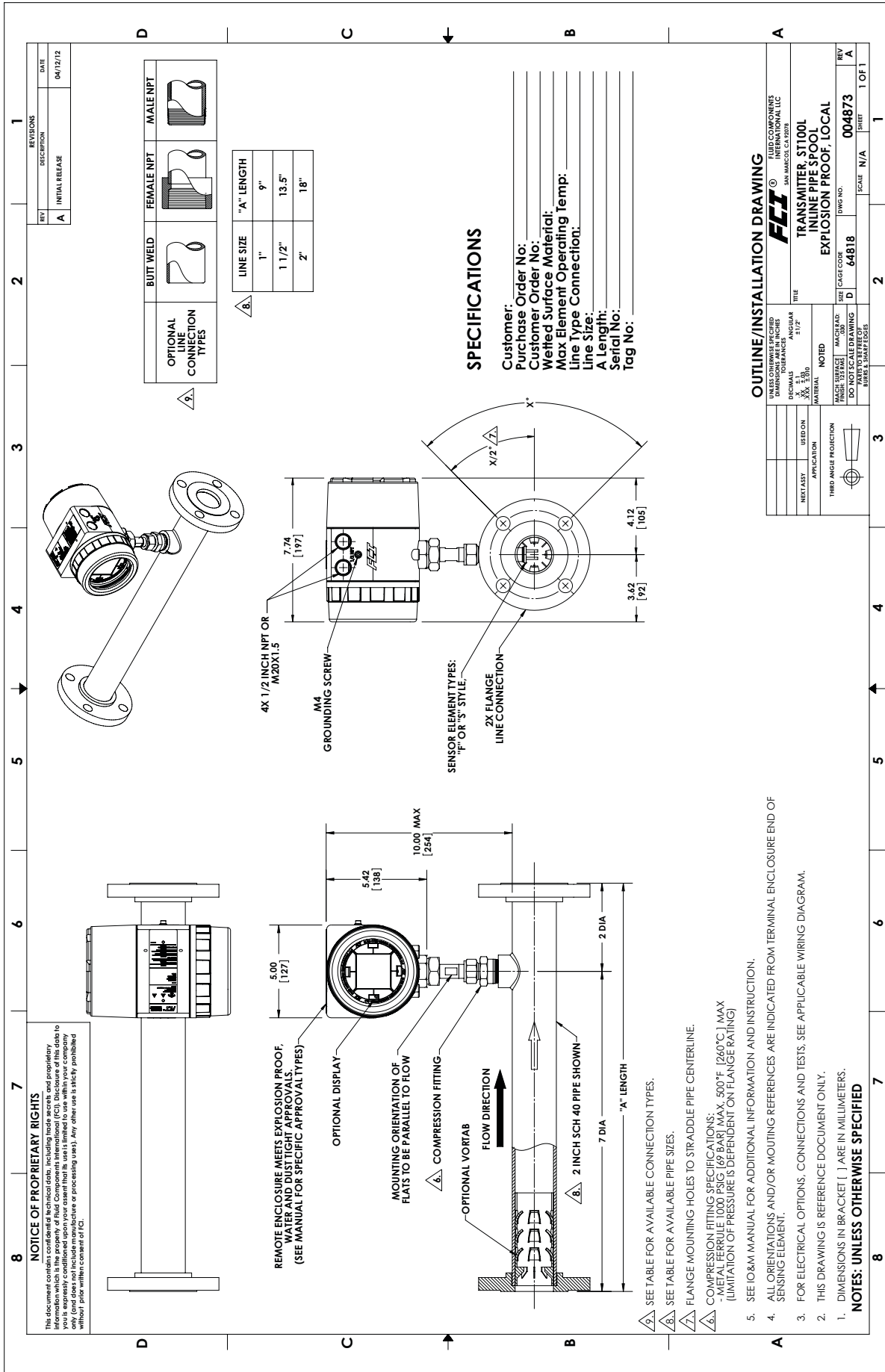

OUTLINE/INSTALLATION DRAWING

FCI FLUID COMPONENTS INTERNATIONAL LLC SAN MARCOS, CA 92078	ANGULAR 4:1/1/2
TITLE TRANSMITTER, ST100L INLINE PIPE SPOOL EXPLOSION PROOF, LOCAL	NOTED MACH UNLESS INDICATED DO NOT SCALE DRAWING BASED ON DIMENSIONS OF PARTS
DWG NO. 64818	SCALE N/A
SHEET 1 OF 1	REV A

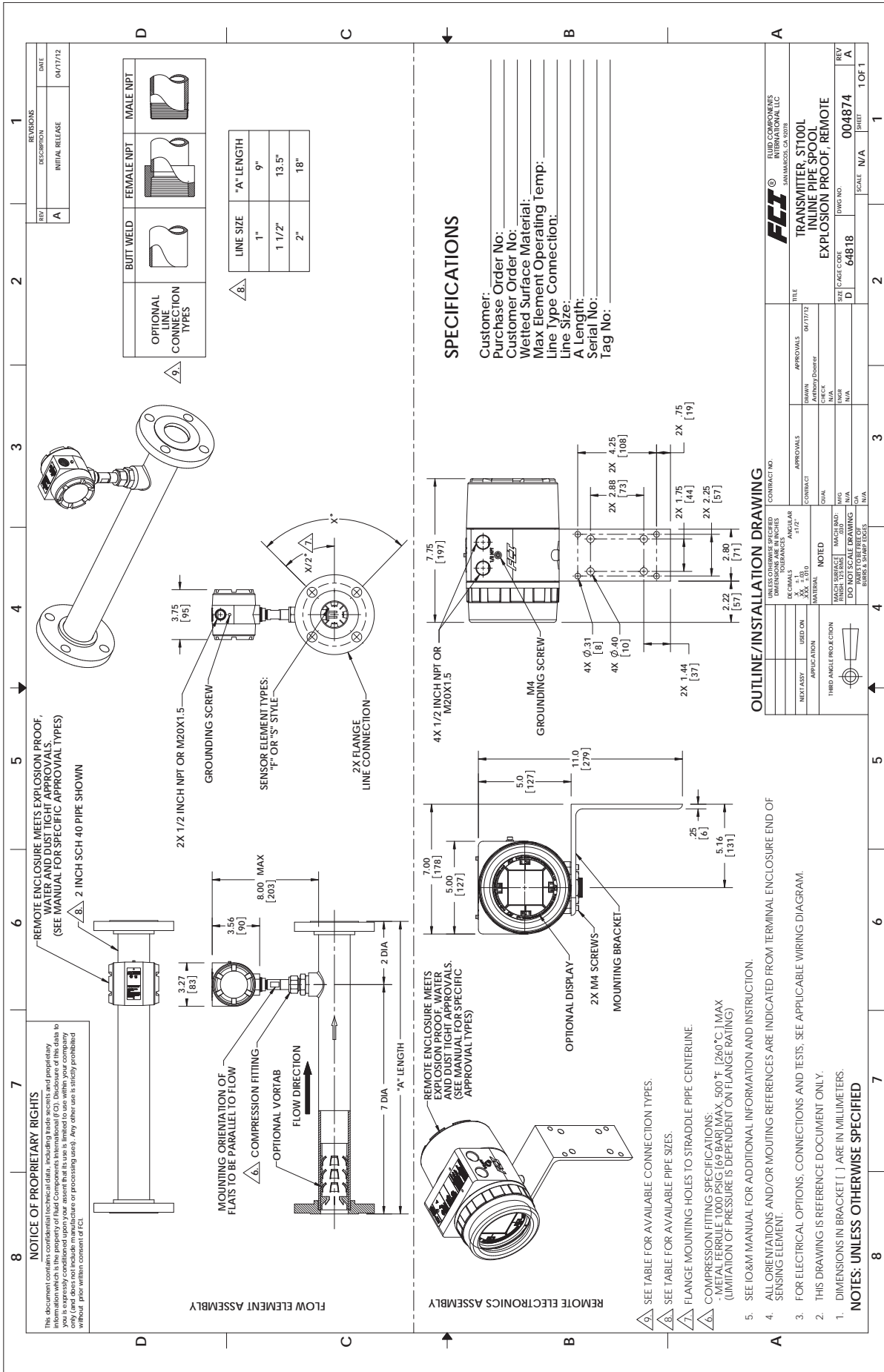

NOTICE OF PROPRIETARY RIGHTS
 This document contains confidential technical data, including trade secrets and proprietary information. It is intended for use only by the recipient and is not to be disseminated to any other person without your prior written consent. If you are not the intended recipient, you are expressly notified that any disclosure, copying, distribution, or use of this document is strictly prohibited. If you have received this document in error, please notify the sender immediately.

REV	DESCRIPTION	DATE
1	INITIAL RELEASE	04/17/12

OPTIONAL LINE CONNECTION TYPES	BUTT WELD	FEMALE NPT	MALE NPT

LINE SIZE	"A" LENGTH
1"	9"
1 1/2"	13.5"
2"	18"

REMOTE ENCLOSURE MEETS EXPLOSION PROOF, WATER AND DUST TIGHT APPROVALS. (SEE MANUAL FOR SPECIFIC APPROVAL TYPES)

2 INCH SCH 40 PIPE SHOWN

3.75 [95]
 2X 1/2 INCH NPT OR M20X1.5
 GROUNDING SCREW

SENSOR ELEMENT TYPES:
 "F" OR "S" STYLE

2X FLANGE LINE CONNECTION

8.00 MAX [203]

3.56 [90]

3.27 [83]

8.00 MAX [203]

2 DIA

7 DIA

"A" LENGTH

FLOW DIRECTION

COMPRESSION FITTING
 FLATS TO BE PARALLEL TO FLOW

OPTIONAL VORTAB

7.00 [178]

5.00 [127]

7.75 [197]

4X 1/2 INCH NPT OR M20X1.5
 GROUNDING SCREW

M4 GROUNDING SCREW

4X ϕ .31 [8]

4X ϕ .40 [10]

2X 1.75 [44]

2X 1.44 [37]

2X 2.25 [57]

2.80 [71]

2.22 [57]

OPTIONAL DISPLAY

2X M4 SCREWS

MOUNTING BRACKET

5.0 [127]

11.0 [279]

7.00 [178]

5.00 [127]

7.00 [178]

5.16 [131]

.25 [6]

REMOTE ENCLOSURE MEETS EXPLOSION PROOF, WATER AND DUST TIGHT APPROVALS. (SEE MANUAL FOR SPECIFIC APPROVAL TYPES)

OPTIONAL DISPLAY

MOUNTING BRACKET

2X M4 SCREWS

8 7 6 5 4 3 2 1

SPECIFICATIONS

Customer:
 Purchase Order No: _____
 Customer Order No: _____
 Wetted Surface Material: _____
 Max Element Operating Temp: _____
 Line Type Connection: _____
 Line Size: _____
 A Length: _____
 Serial No: _____
 Tag No: _____

REV	DESCRIPTION	DATE
1	INITIAL RELEASE	04/17/12

OPTIONAL LINE CONNECTION TYPES	BUTT WELD	FEMALE NPT	MALE NPT

LINE SIZE	"A" LENGTH
1"	9"
1 1/2"	13.5"
2"	18"

OUTLINE/INSTALLATION DRAWING

APPROVALS	CONTRACT NO.	UNIT OF MEASURE	CONTRACT
		ANGULAR	
		DECIMALS	
		INCHES	
		PERCENTS	
		TOLERANCES	
		XXX.XX	
		XXX.X	
		XXX.XX	
		1/16"	
		1/32"	

APPROVALS	TITLE	DATE
APPROVED	TRANSMITTER, ST100L	09/17/12
DRAWN	INLINE PIPE SPOOL	
CHECKED	EXPLOSION PROOF, REMOTE	
DESIGNED		
DATE		
N/A		
N/A		
N/A		
N/A		
N/A		

THIRD ANGLE PROJECTION

DATE	SCALE	SHEET	OF
04/17/12	N/A	1	1

NOTES:

- DIMENSIONS IN BRACKET [] ARE IN MILLIMETERS.
- THIS DRAWING IS REFERENCE DOCUMENT ONLY.
- FOR ELECTRICAL OPTIONS, CONNECTIONS AND TESTS, SEE APPLICABLE WIRING DIAGRAM.
- ALL ORIENTATIONS AND/OR MOUNTING REFERENCES ARE INDICATED FROM TERMINAL ENCLOSURE END OF SENSING ELEMENT.
- SEE IO&M MANUAL FOR ADDITIONAL INFORMATION AND INSTRUCTION.
- SEE IO&M MANUAL FOR ADDITIONAL INFORMATION AND INSTRUCTION.
- FRANGE MOUNTING HOLES TO STRADDLE PIPE CENTERLINE.
- COMPRESSION FITTING SPECIFICATIONS:
 - METAL FERULE: 1000 PSIG (69 BAR) MAX, 500 °F (260 °C) MAX.
 (LIMITATION OF PRESSURE IS DEPENDENT ON FLANGE RATING)
- SEE IO&M MANUAL FOR ADDITIONAL INFORMATION AND INSTRUCTION.

NOTES: UNLESS OTHERWISE SPECIFIED

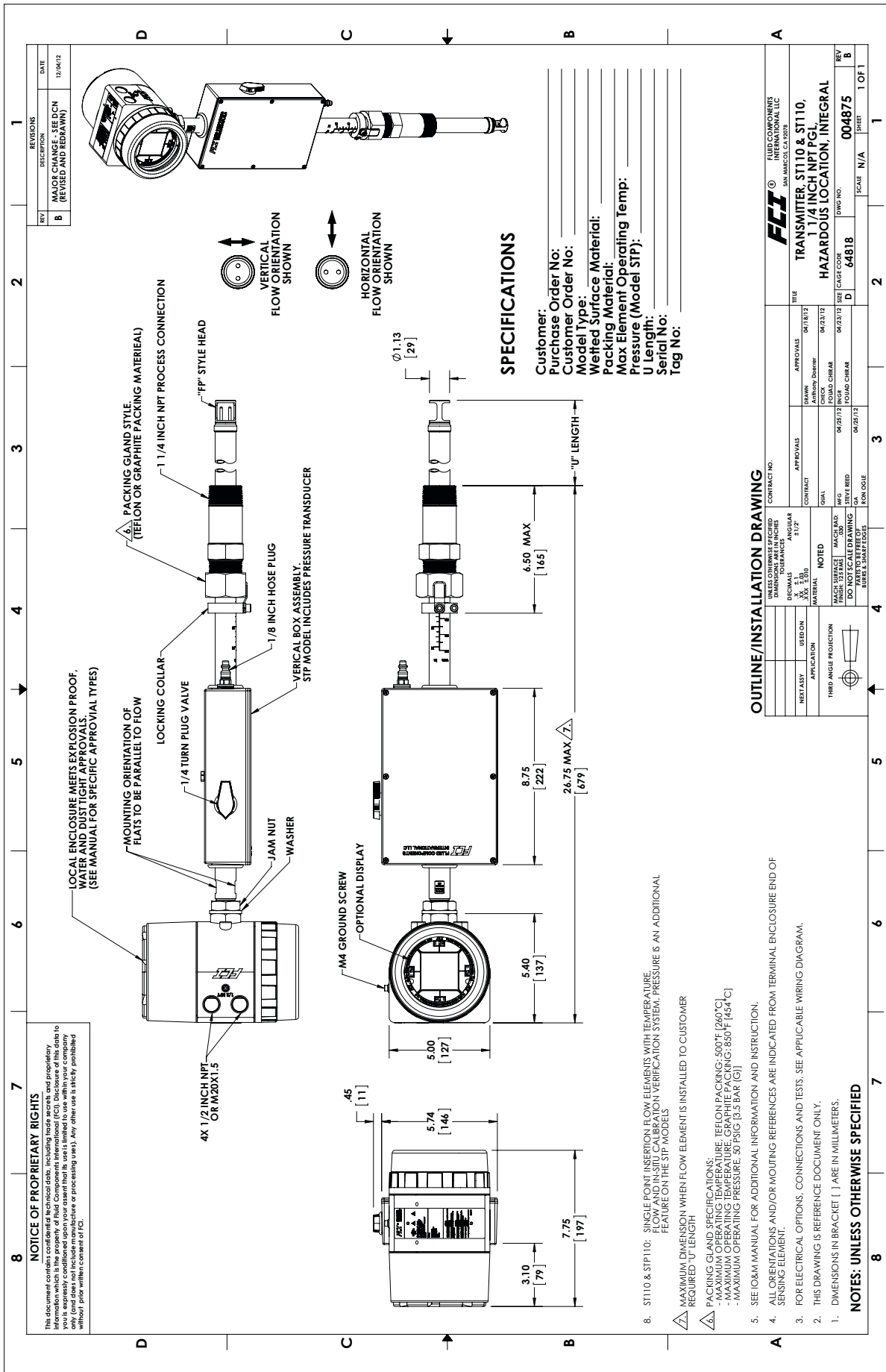

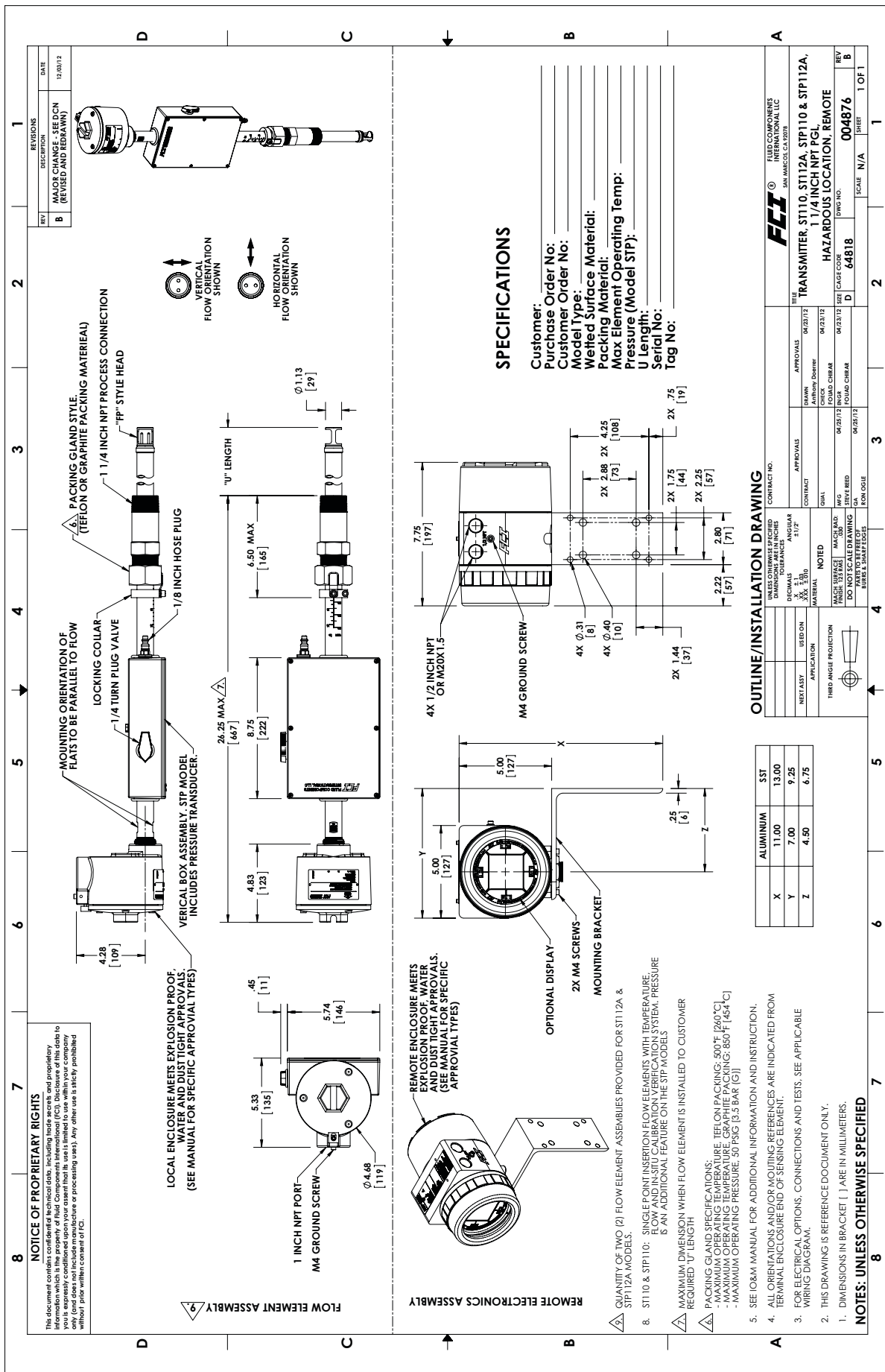

Intentionally Left Blank

APPENDIX B WIRING DIAGRAMS

Appendix B provides the following wiring diagrams:

- Integral: AC Input Power, Analog and HART Output
- Remote: AC Input Power, Analog and HART Output
- Integral: DC Input Power, Analog and HART Output
- Remote: DC Input Power, Analog and HART Output
- Integral: AC Input Power, FOUNDATION Fieldbus Output
- Remote: AC Input Power, FOUNDATION Fieldbus Output
- Integral: DC Input Power, FOUNDATION Fieldbus Output
- Remote: DC Input Power, FOUNDATION Fieldbus Output
- Integral: AC Input Power, Modbus Output
- Remote: AC Input Power, Modbus Output
- Integral: DC Input Power, Modbus Output
- Remote: DC Input Power, Modbus Output
- Remote: 8-Conductor Interconnection Cable
- Source: Pulse/Frequency Output
- Sink: Pulse/Frequency Output
- Flow Element Connection, Integral/Remote
- Flow Element Connection, Remote
- Remote: 10-Conductor Interconnection Cable
- Extended Operation Mode, External Input Flow Adjust (EIA)
- Extended Operation Mode, External ST100 Flow Input (EFI)

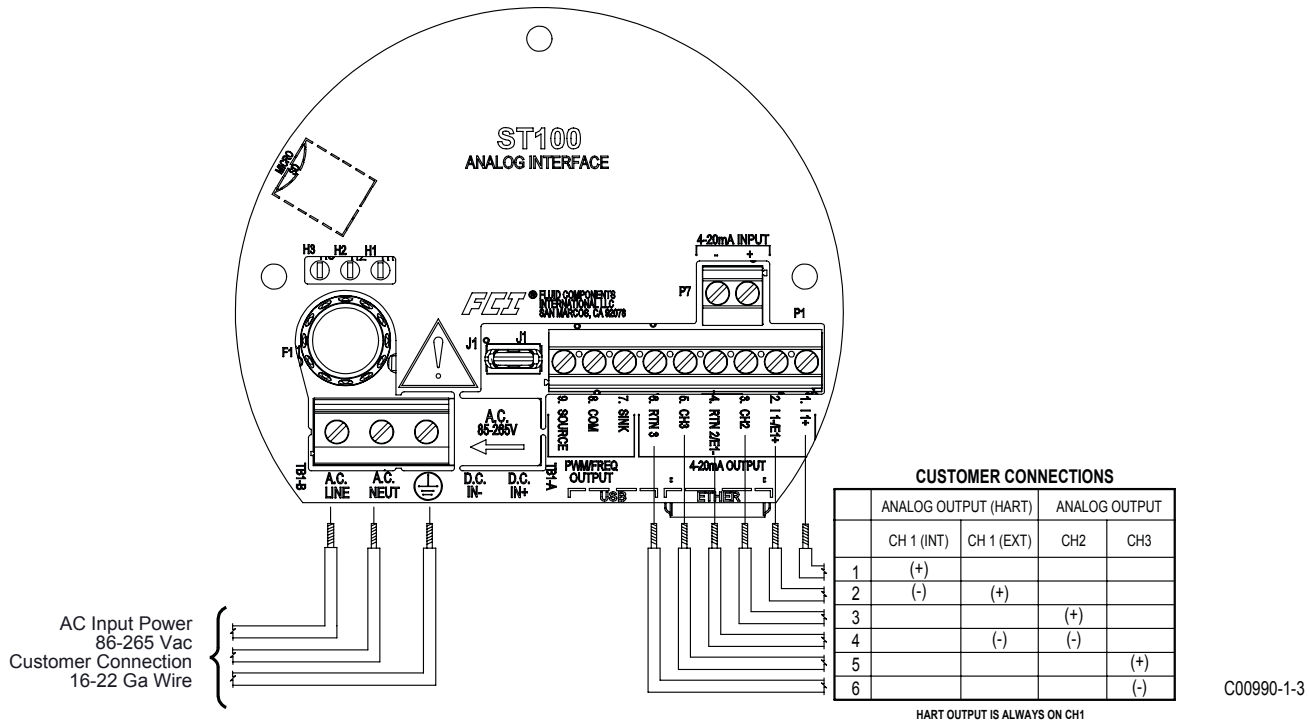

Figure B-1 – Integral: AC Input Power, Analog and HART Output

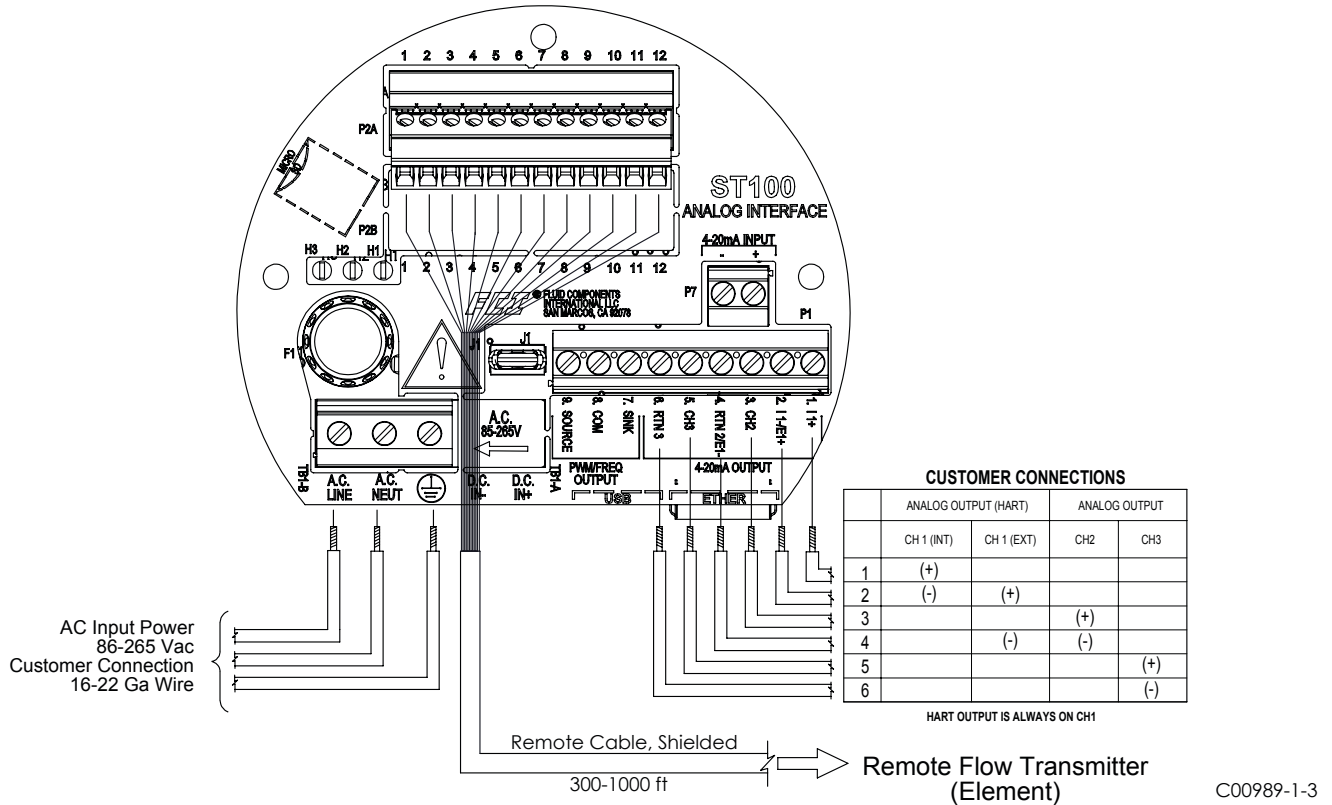
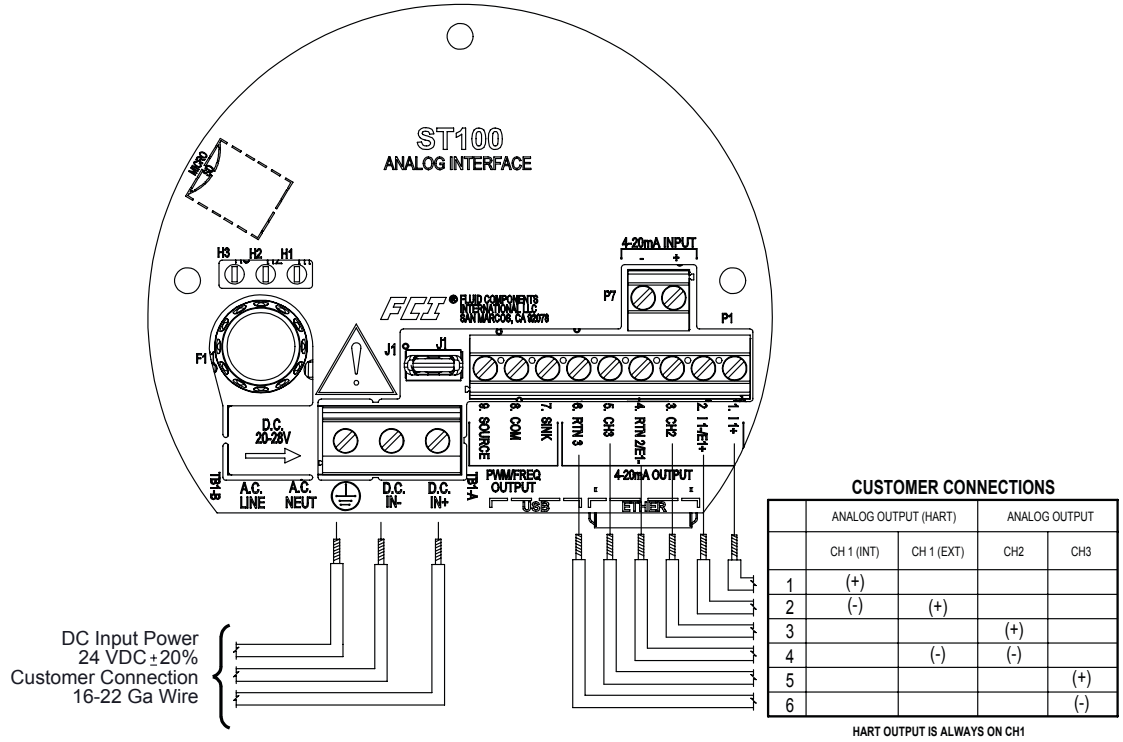
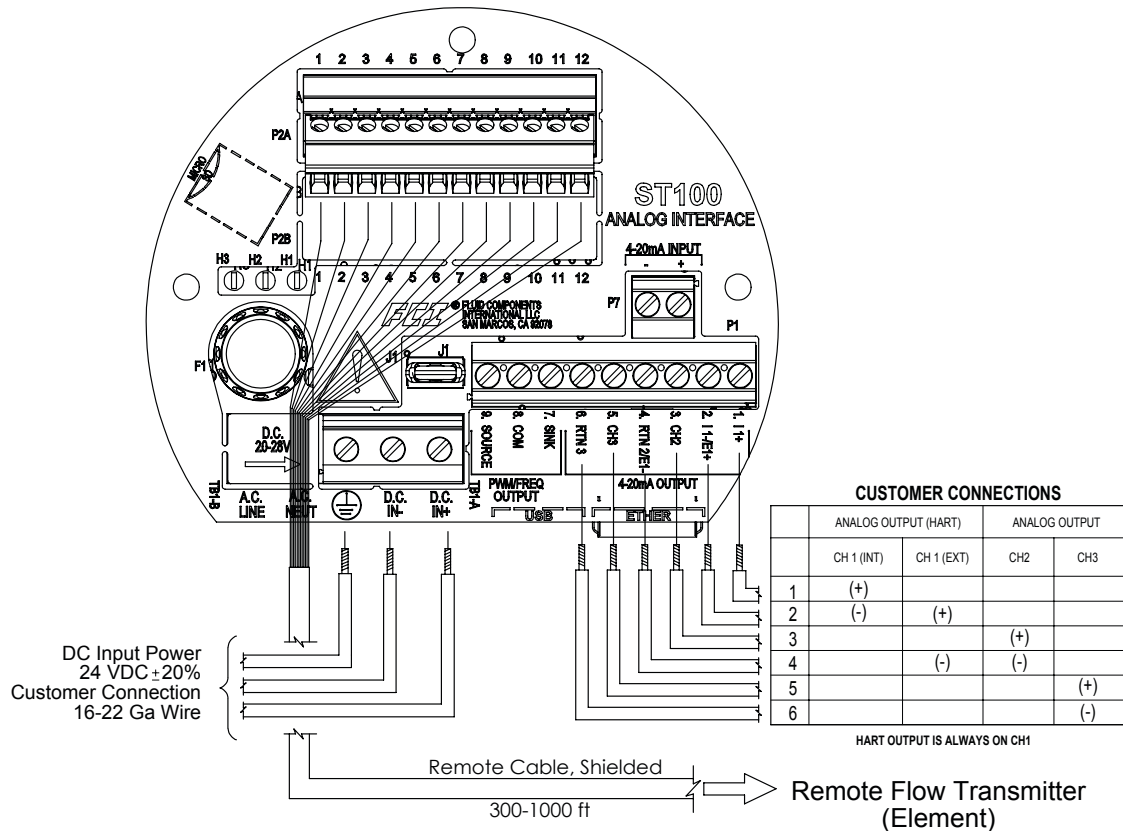

Figure B-2 – Remote: AC Input Power, Analog and HART Output



C00999-1-3

Figure B-3 – Integral: DC Input Power, Analog and HART Output



C01116-1-1

Figure B-4 – Remote: DC Input Power, Analog and HART Output

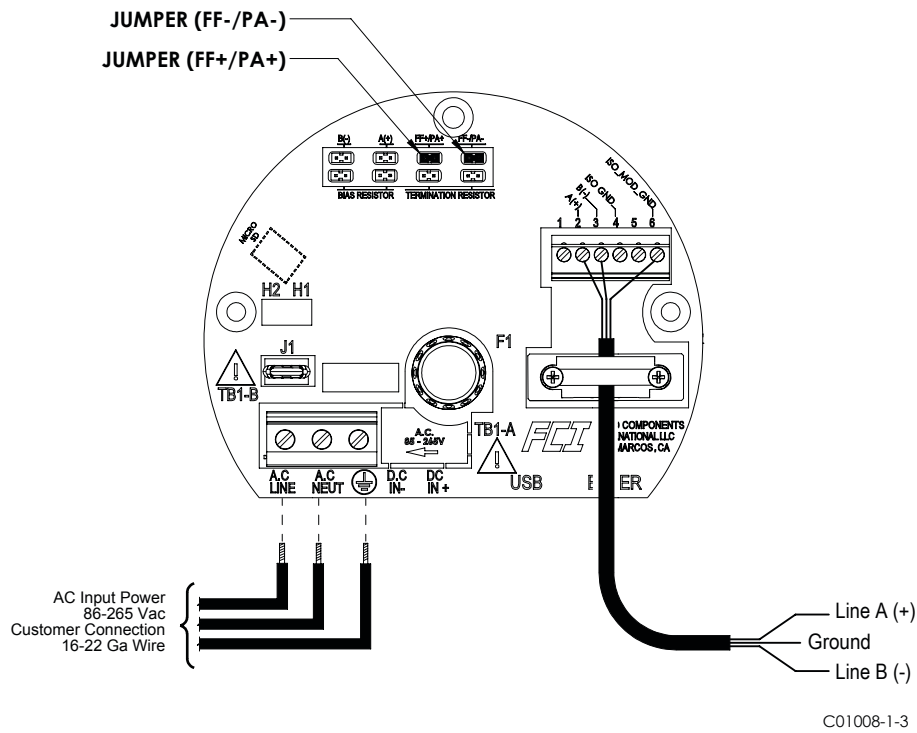

Figure B-5 – Integral: AC Input Power, FOUNDATION Fieldbus Output

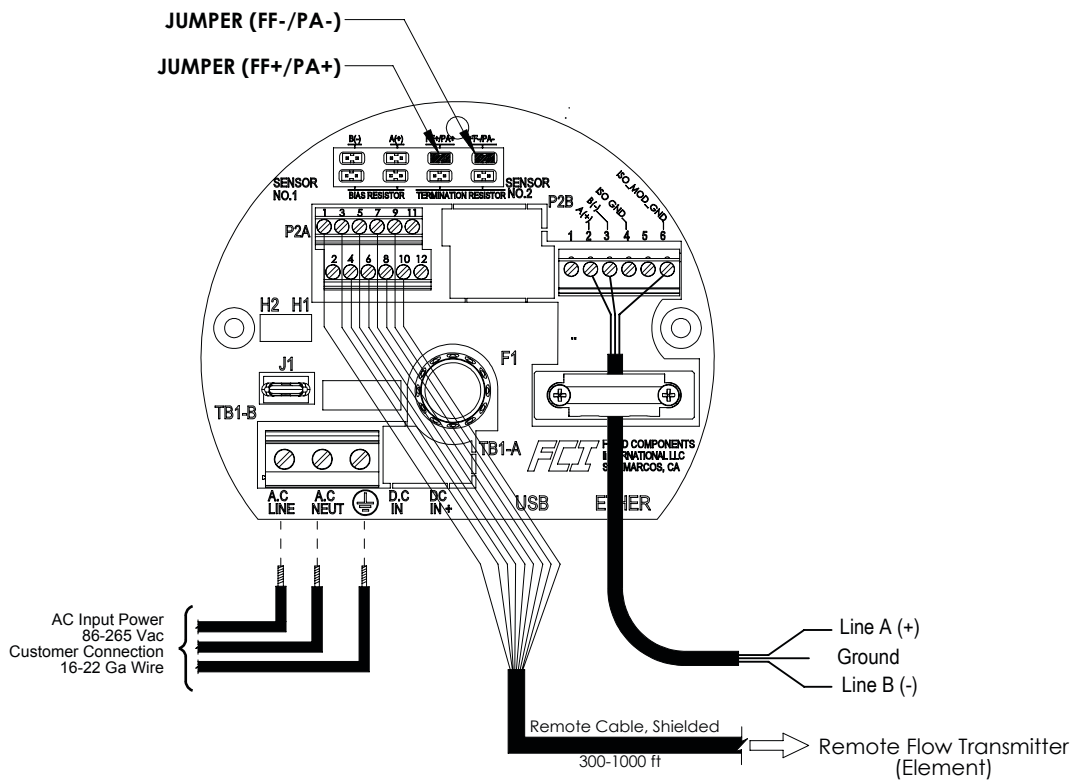
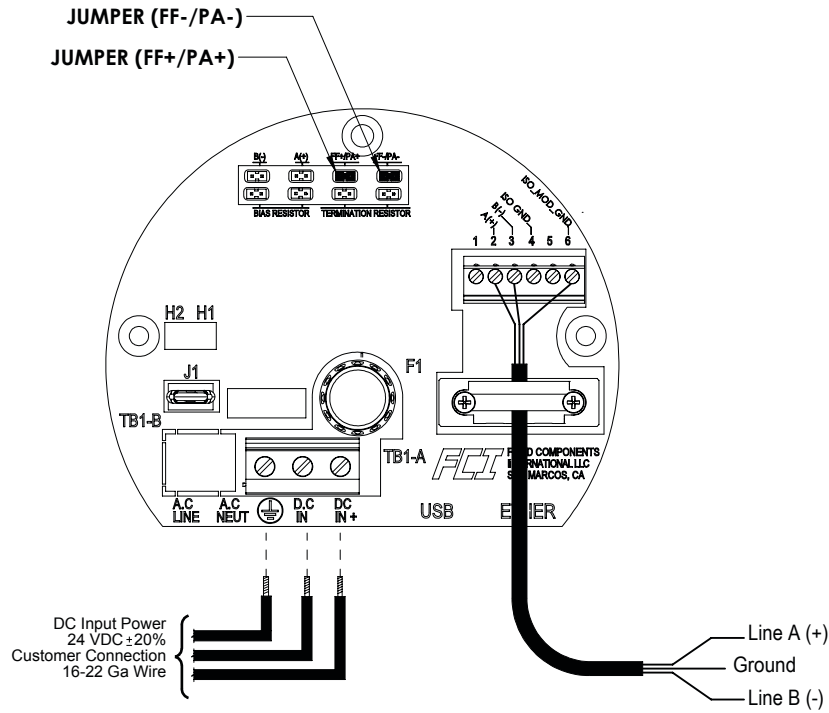
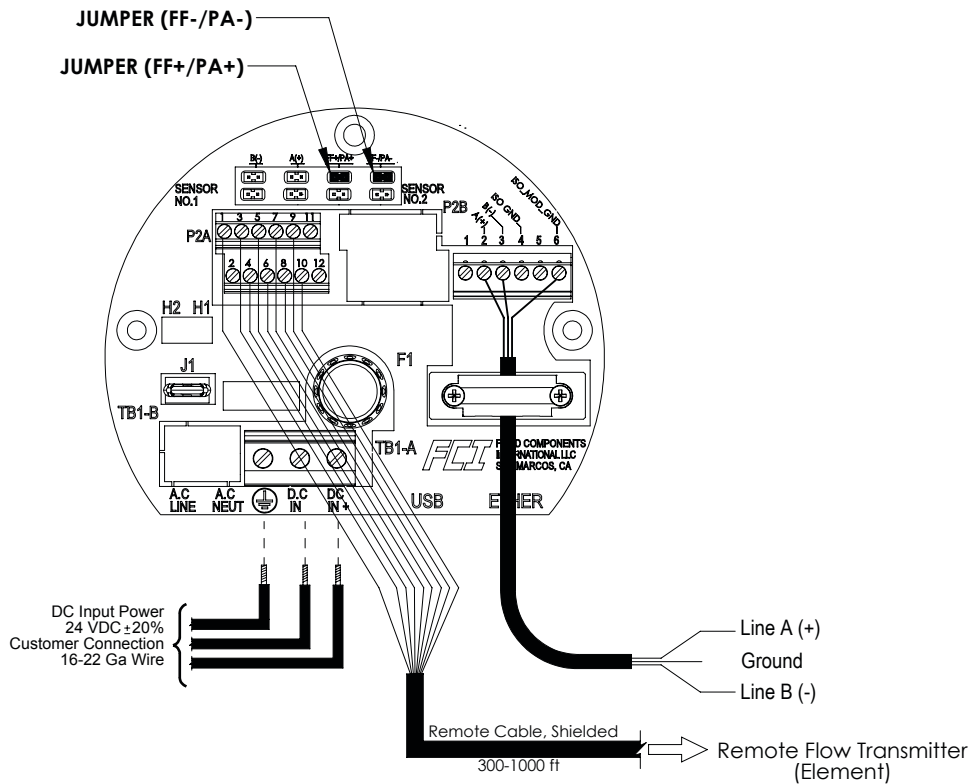

Figure B-6 – Remote: AC Input Power, FOUNDATION Fieldbus Output



C01010-1-3

Figure B-7 – Integral: DC Input Power, FOUNDATION Fieldbus Output



C01007-1-3

Figure B-8 – Remote: DC Input Power, FOUNDATION Fieldbus Output

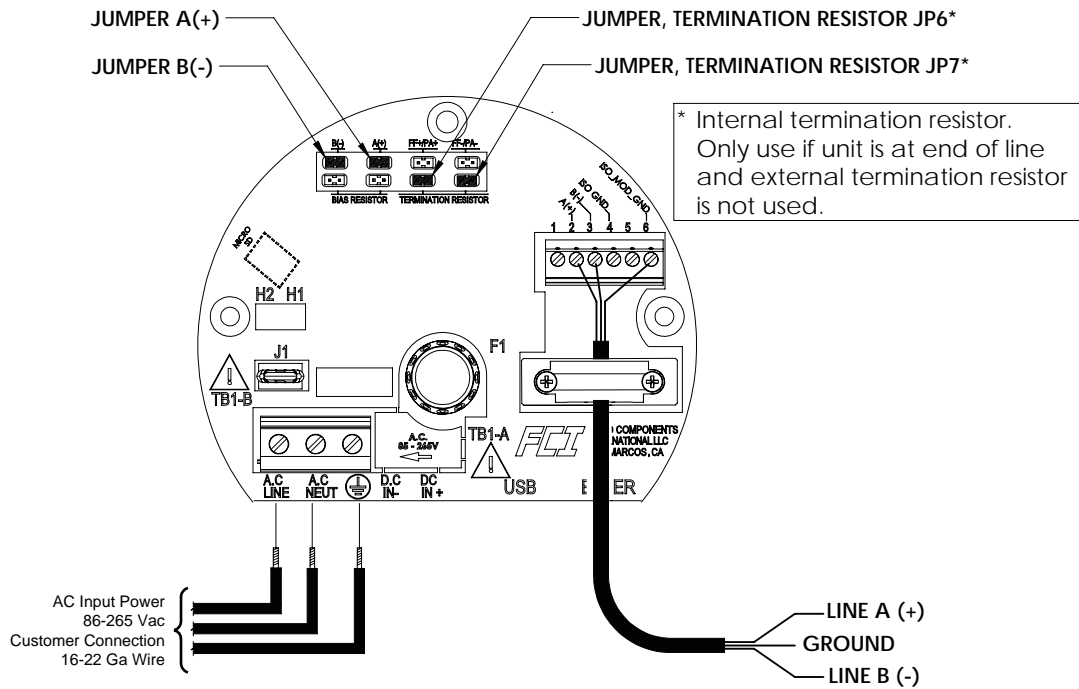

C01014-1-3

Figure B-9 – Integral: AC Input Power, Modbus Output

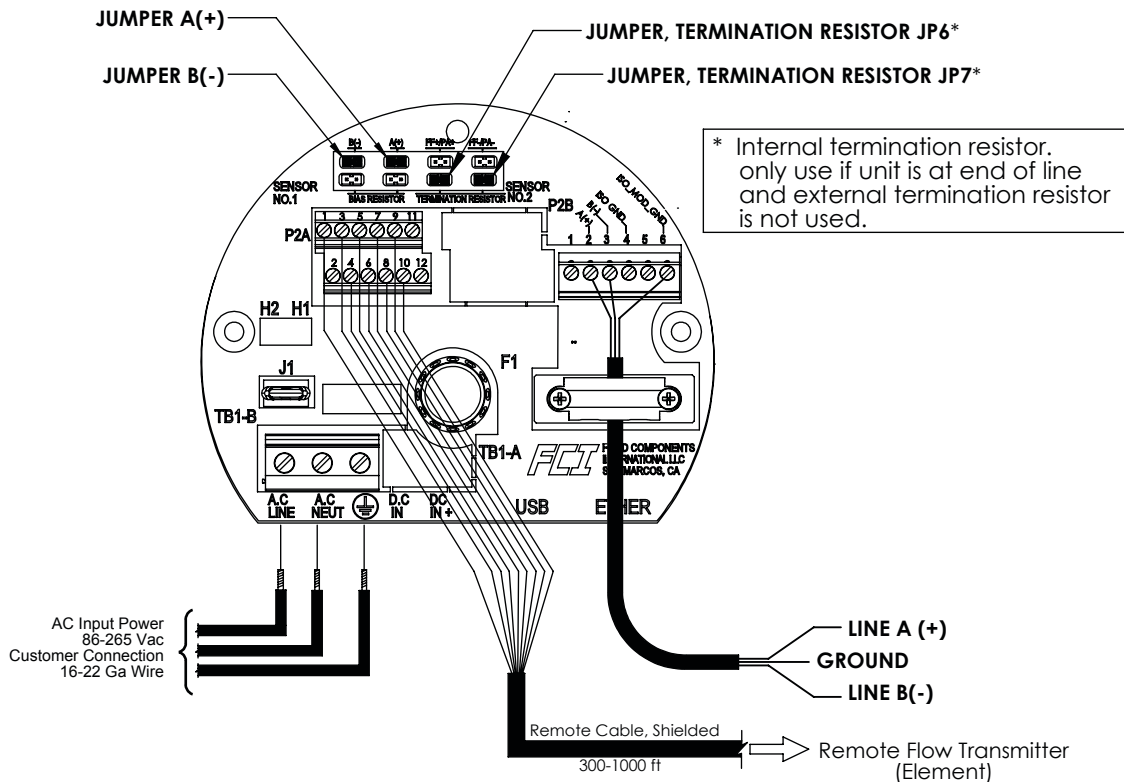

C01011-1-3

Figure B-10 – Remote: AC Input Power, Modbus Output

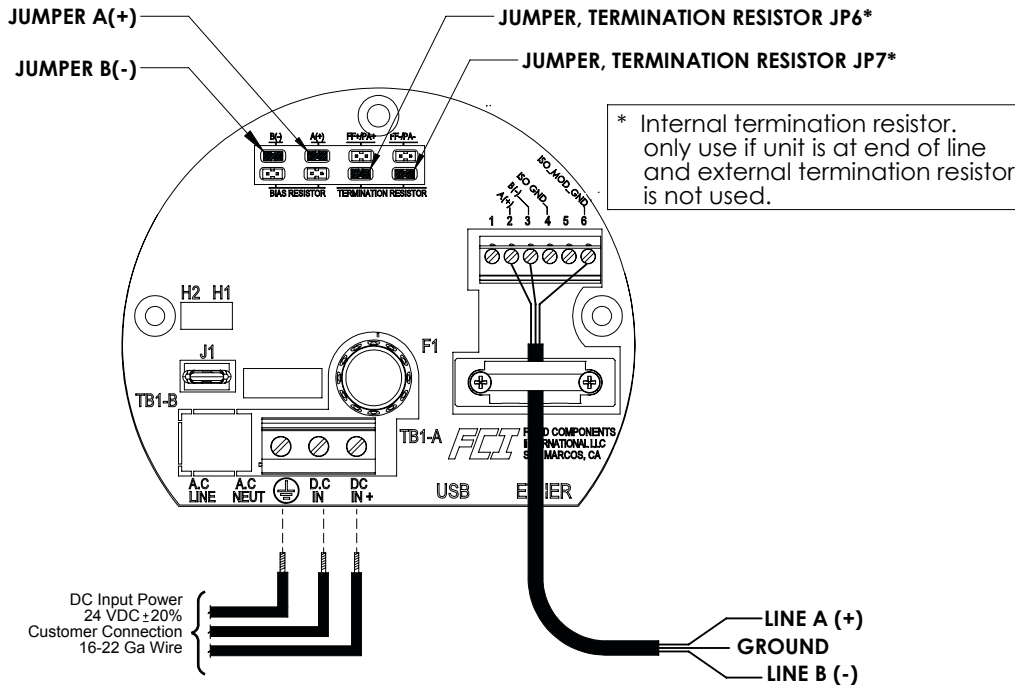

C01013-1-3

Figure B-11 – Integral: DC Input Power, Modbus Output

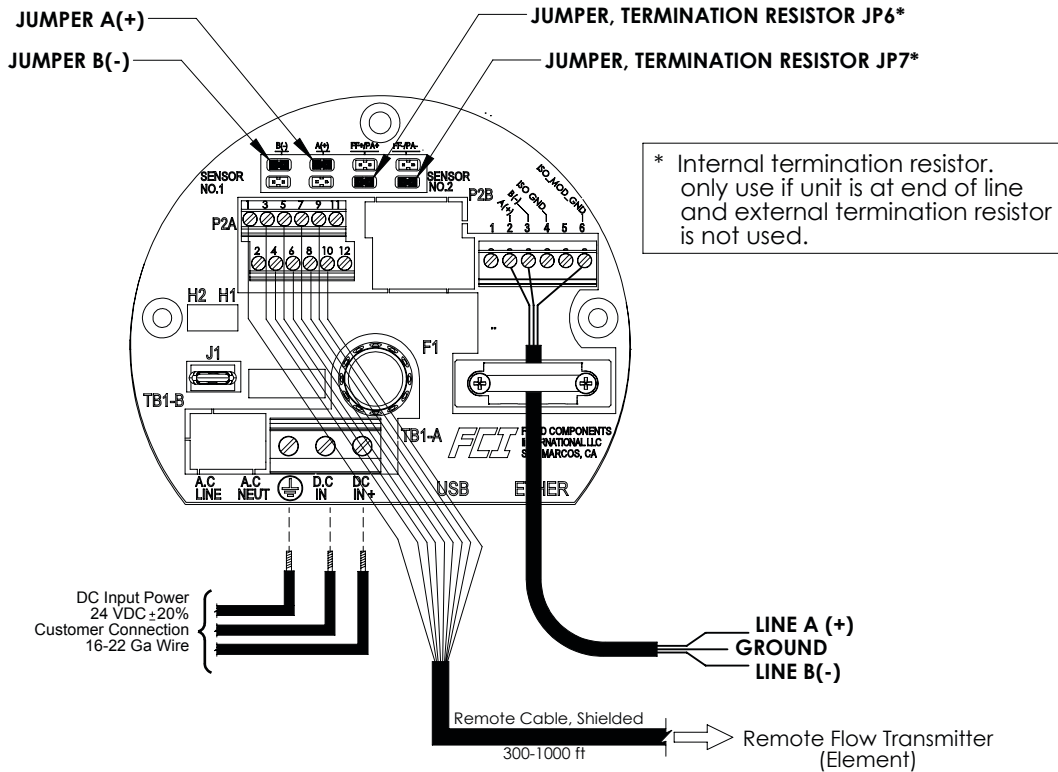

C01012-1-3

Figure B-12 – Remote: DC Input Power, Modbus Output

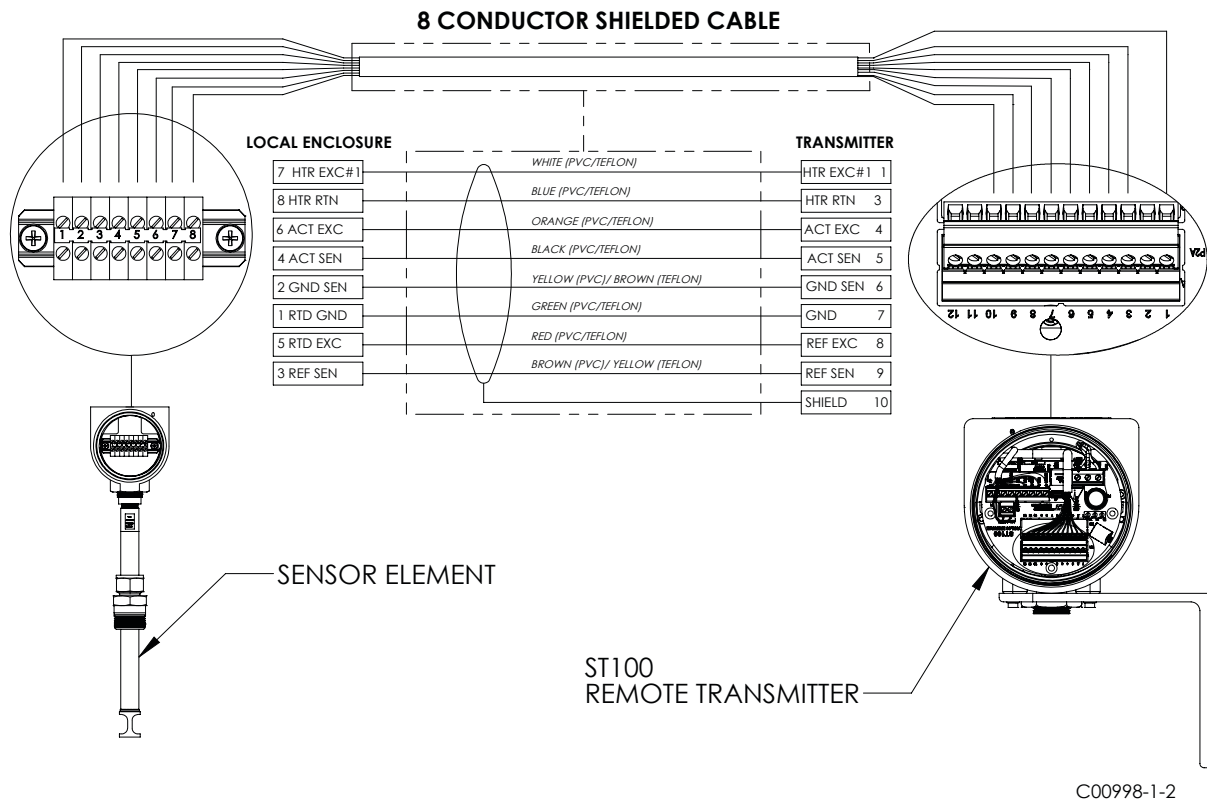

Figure B-13 – Remote: 8-Conductor Interconnection Cable

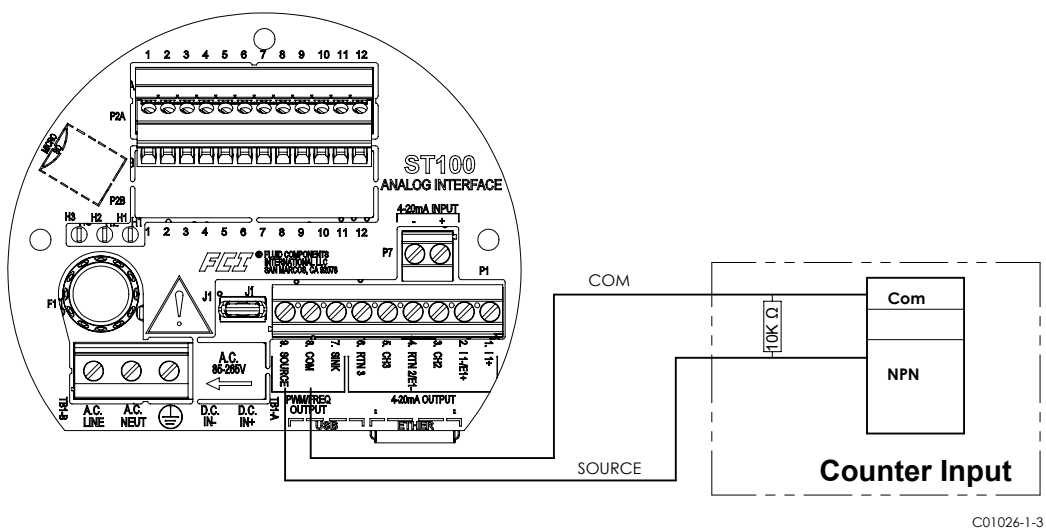

Figure B-14 – Source, Pulse/Frequency Output

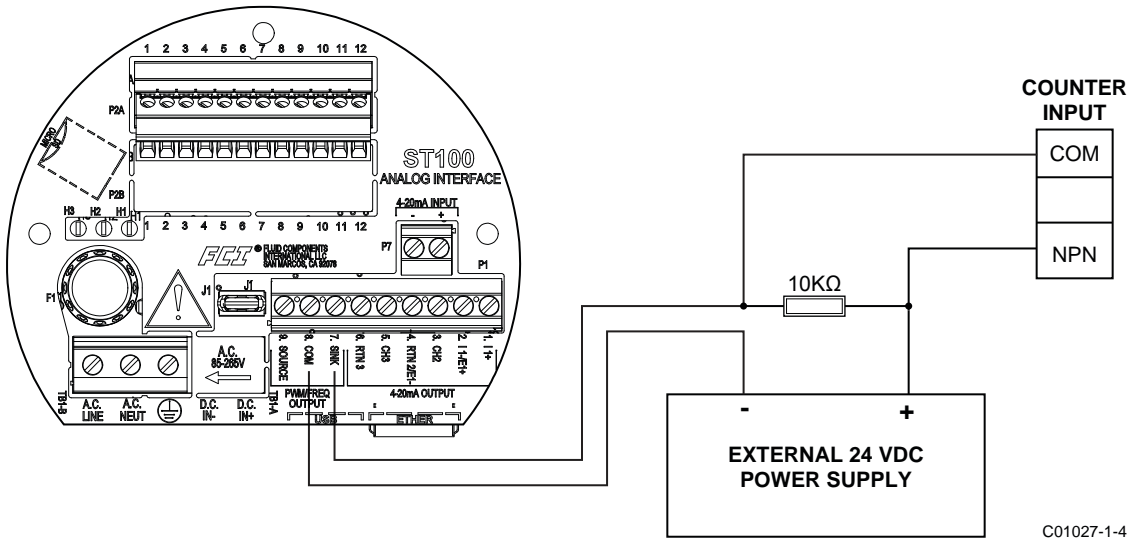

Figure B-15 – Sink, Pulse/Frequency Output

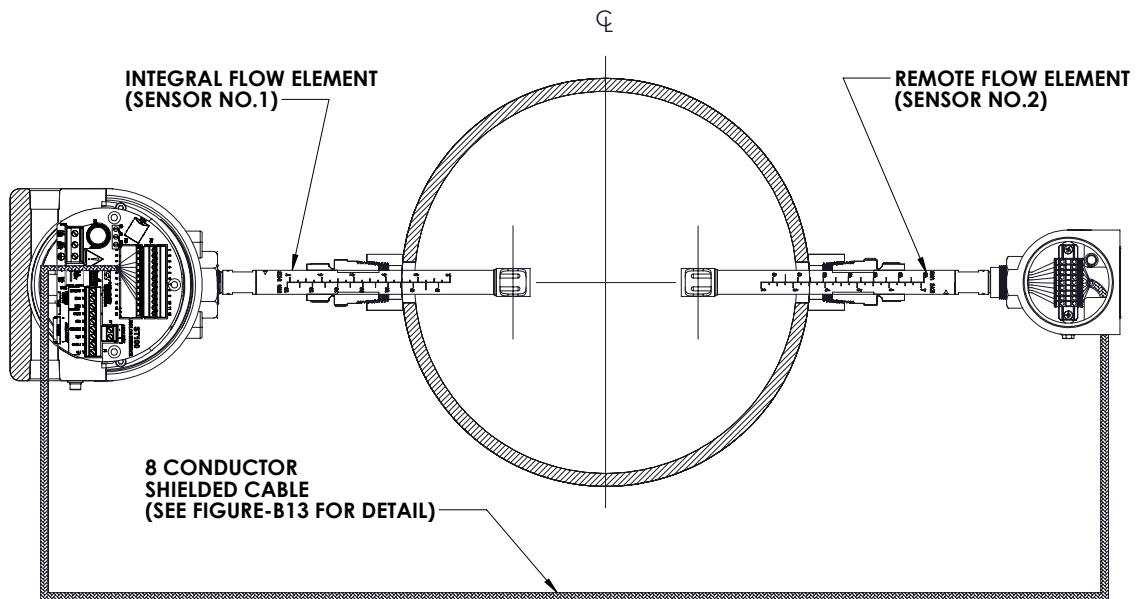

Figure B-16 – Flow Element Connection, Integral/Remote

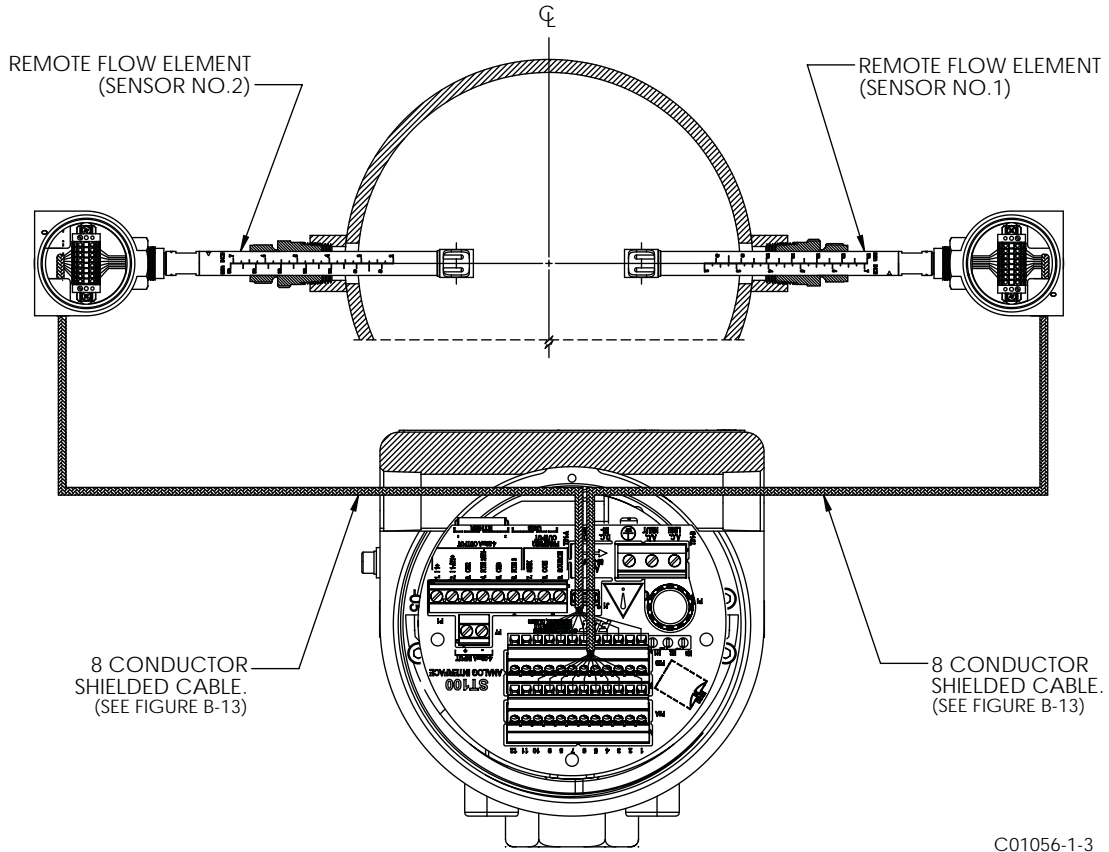

Figure B-17 – Flow Element Connection, Remote

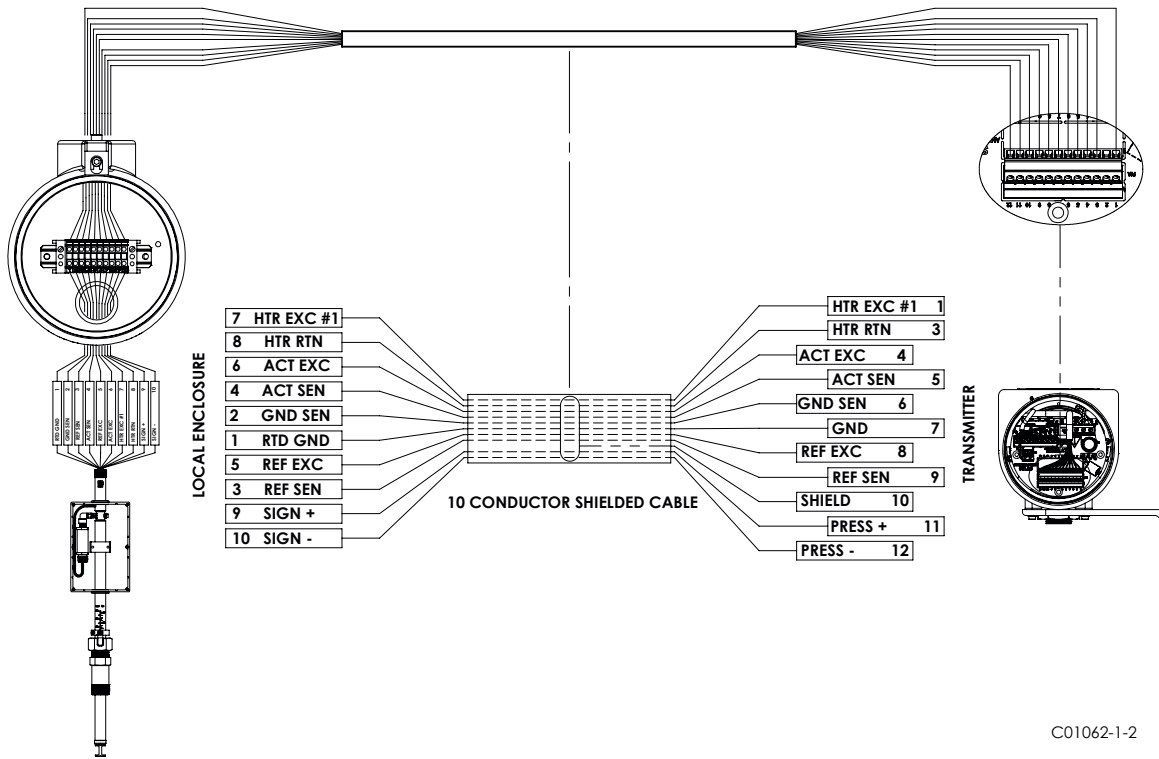
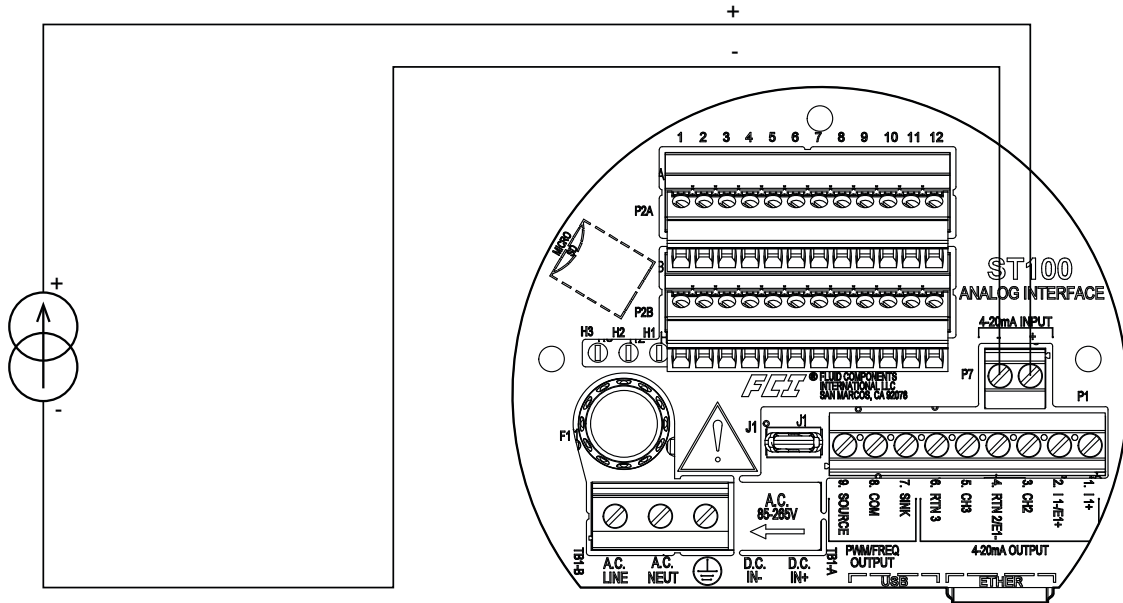

Figure B-18 – Remote: 10-Conductor Interconnection Cable

NOTE: ST102 AC power, dual remote interface board shown.



External 4-20 mA Current Source

ST100 Series Interface Board (Analog)

C01340-1-1

Figure B-19 – Extended Operation Mode, External Input Flow Adjust (EIA)

NOTE: ST102 AC power, dual remote interface board shown, 2 places.

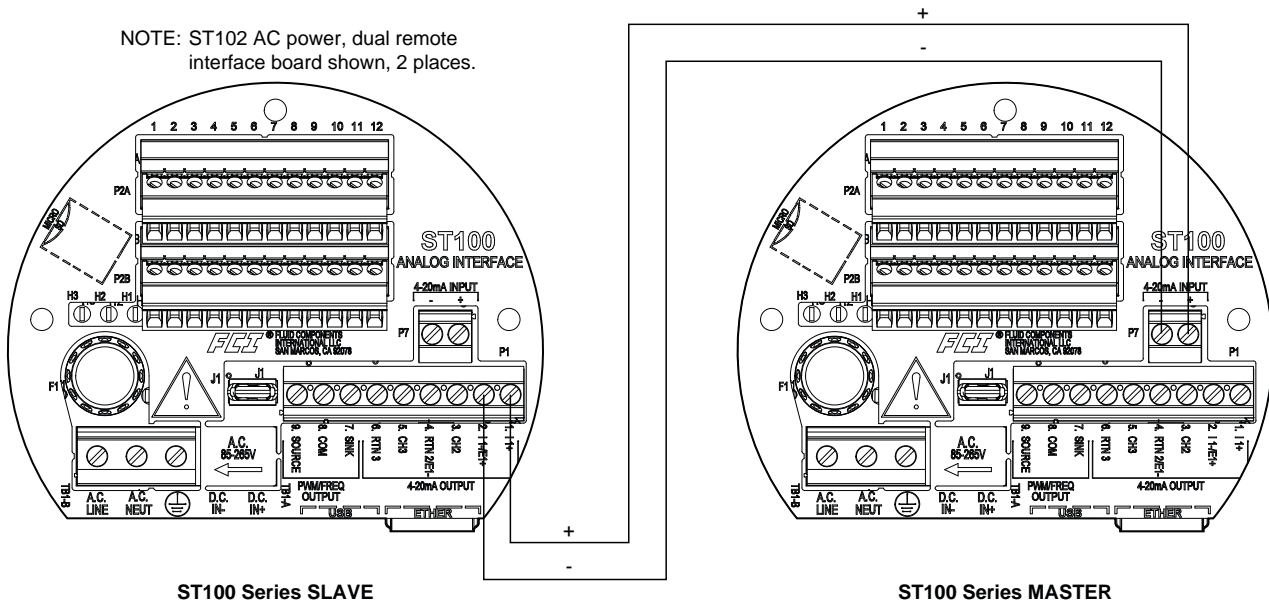

ST100 Series SLAVE

ST100 Series MASTER

C01126-2-1

Figure B-20 – Extended Operation Mode, External ST100 Flow Input (EFI)

**Generation 1 ST100 Series - Analog and HART Wiring
Units Shipped April 2012 through July 2013**

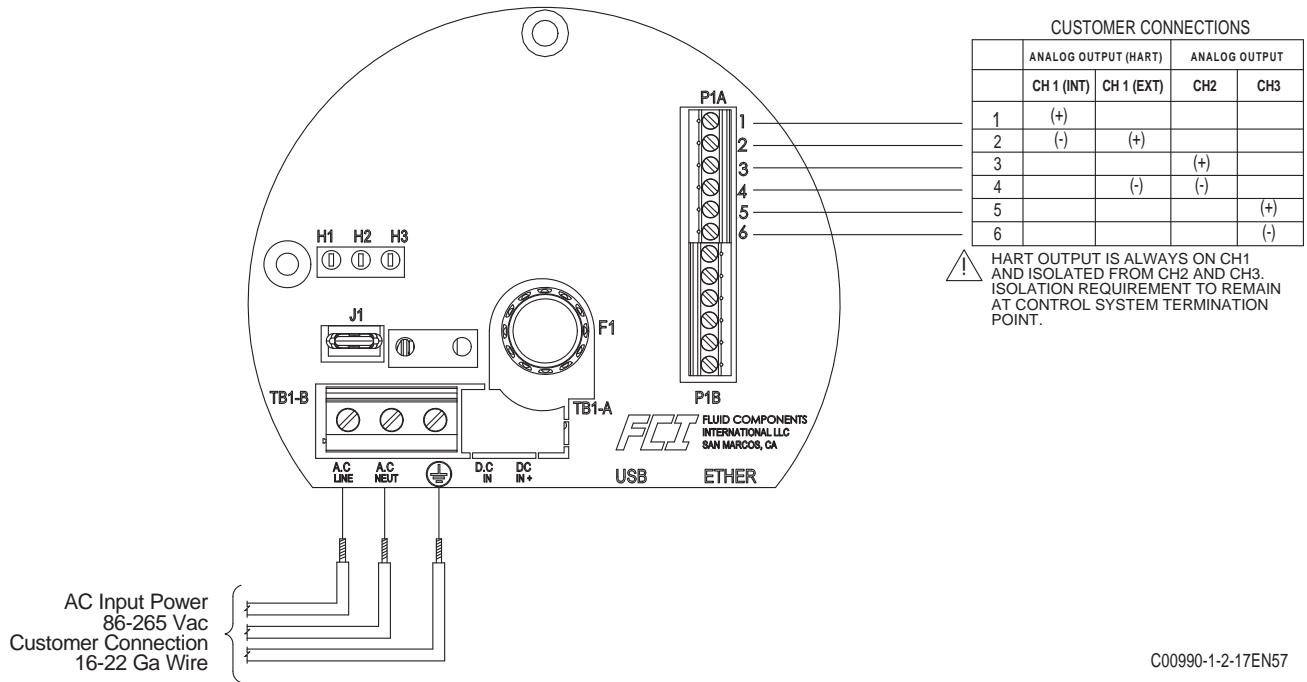

Integral - AC Input Power, Analog and HART Output

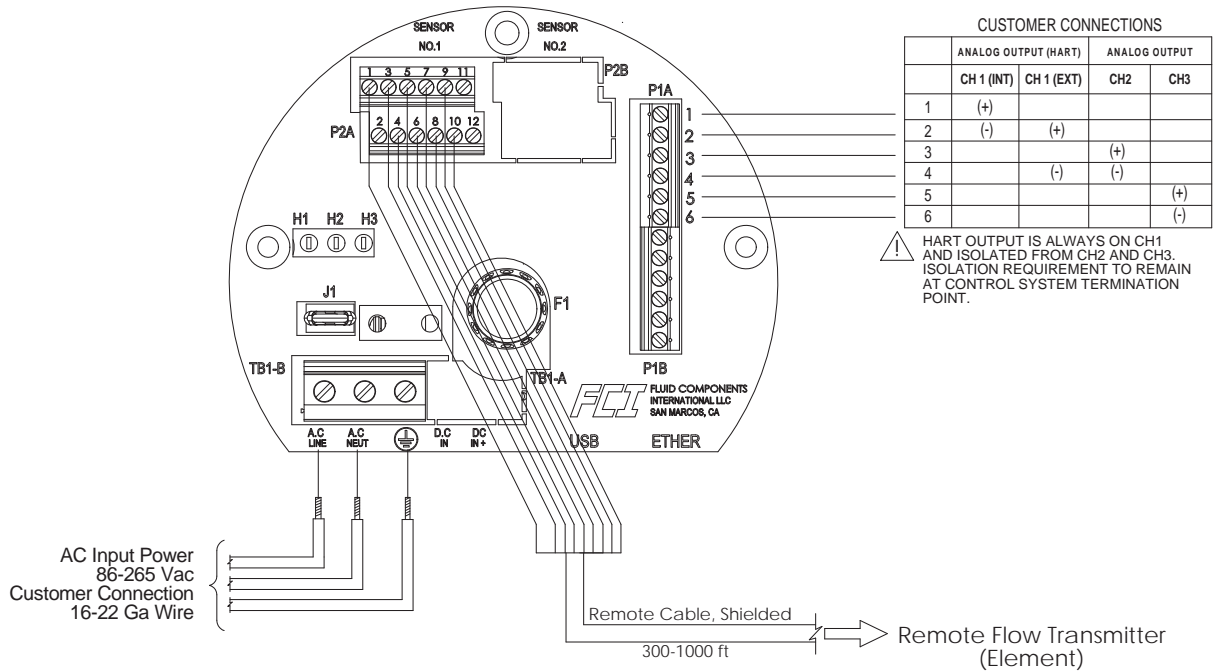

Remote - AC Input Power, Analog and HART Output

APPENDIX C ADDITIONAL INFORMATION

This appendix contains the following information:

- Delta R Sheet (Sample)
- Parameters Report from the ST100 Configuration Application (Sample)
- HMI Menu Outline (v2.99)
- Internal Delta-R Resistor Check (IDR) HMI Display Sequence
- ST100 Configuration Software Menu Outline (v2.2.0.x)
- Instructions: Installing Ferrite Onto ST100 Series DC Power Cable

Delta R Sheet (Sample)

FCI FLUID COMPONENTS INTL
 A limited liability company
 1755 La Costa Meadows Drive, San Marcos, California 92078
 (760) 744-6950 (800) 854-1993 FAX: (760) 736-6250
 www.fluidcomponents.com

ST100 Delta 'R
ST100-70D01202A0B1EBG0003

C#:	C064202	Serial:	440103	Dec-Box	Equip...	Cal. Due
Cust.:	EMERSON PROCESS MGMT	Date:	May 23, 2013	(Act):	EL-710	11-Sep-13
Tag:	BB18-FZIT-521012	TagR1:	N/A	(Ref):	EL-318	04-Dec-13
TagL2:	N/A	TagR2:	N/A	DVM:	EL-488	03-May-14
TagL3:	N/A	TagR3:	N/A	250 ohm:	EL-210	25-Jan-14

Nominal Sensor Resistance:	1000 Ω
Indicated Temperature at Nominal Resistance:	-0.01 C

Test Tech.	227
------------	-----

Notes: ST100, calibration group 1.

Delta 'R (ohms)	VDC 250 ohms	mA Output	Unit dR	Unit TCdR	Indicated NCMH
271.80	1.001	4.00	271.795	264.89	0.000
271.55	1.107	4.43	271.545	264.64	1005
235.93	1.216	4.86	235.921	230.01	2048
192.04	1.500	6.00	192.020	187.32	4726
158.84	2.000	8.00	158.823	155.04	9448
127.08	3.002	12.01	127.051	124.16	18900
109.97	3.999	16.00	109.942	107.52	28360
98.82	4.986	19.94	98.788	96.67	37700

Core Vers.	2.98
	15 Apr. 13
	0DC508B
FE Vers.	V 1.60
	7EF9DD9
HMI Vers.	2.96

Serial #:	440103	Anag. Out 1	Flow (HART)	Curve	Spline	Low
C Number:	C064202	4 mA:	0	Spl1:	0.8071638,265.3,0.0006599	dR Gn: 0.99969
Range		4 mA DAC1:	10408	Spl2:	1.668139,230.01,-3.723845	dR Off: 0.22852
Cust Min:	0	20 mA:	37833.4	Spl3:	2.233153,214.03,0.0016728	R Gn: 1.0003
Cust Max:	37833.4	20 mA DAC1:	54245	Spl4:	3.226662,196.35,0.0008172	R Off: -1.0003
Flow Unit:	78 (NCMH)	Namur, DAC1:	off, 9367	Spl5:	5.362159,171.0,0.00314140	
Line	606	Anag. Out 2	Temperature	Spl6:	7.757741,154.7,0.00399867	
Line	1846	4 mA:	0	Spl7:	11.38001,137.6,0.00419228	
Line Units:	mm	4 mA DAC2:	10476	Spl8:	15.46566,123.97,0.0125958	
Correctors		20 mA:	80	Spl9:	19.53137,114.39,0.0090235	
KFactor1:	0	20 mA DAC2:	53994	Spl10:	23.23835,107.28,0.0199487	
KFactor2:	1	Namur, DAC2:	off, 9428	Spl11:	26.79585,101.73,0.0228579	
KFactor3:	0	Anag. Out 3	Temperature	Spl12:	30.8217,96.545,0.03937035	
KFactor4:	0	4 mA:	0	Spl13:	36.99003,90.251,0.0335227	
CalParam		4 mA DAC3:	11996			
Min SFPS:	0.81464	20 mA:	80			
Max	36.99	20 mA DAC3:	55393			
Std:	0.07523531	Namur, DAC3:	off, 10796			
dR Min:	90.251	Normalization	Low Temp			
dR Max:	265.3	dR Gain:	1.248057			
Cal Ref:	1082.25	dR Offset:	0.574675			
tcs1p:	0.00034671	RefR Gain:	1.248673			
tcs1p0:	-0.0077088	RefR Offset:	-1.023616			
Heater	90 mA	Exc 1 DAC:	13077			
Htr 1 DAC:	35163	Exc 2 DAC:	13084			
Htr 2 DAC:	35119	Mac Number:	0 80 194			
Core SN:	440103		220 101 128			

Parameters Report from the ST100 Configuration Application (Sample)

CORE	Date and Time:	6/19/2014 2:23:20 PM
CORE	Serial Number:	
CORE	Cust Number:	
CORE	Cust Name:	
CORE	Core Version:	1.05
CORE	HMI Version:	2.99
CORE	MAC Address:	1E.30.6C.A2.45.5E
CORE	Ext Op Mode:	1
CORE	Ext Op Submode:	0
CORE	4-20mA Inp Adj Gain:	0.9893627
CORE	4-20mA Inp Adj Offset:	-1.885972
CORE	EFI Flow Min.:	0
CORE	EFI Flow Max.:	90
CORE	EFI Flow Units:	84
CORE	EGS Threshold1:	6
CORE	EGS Group1 ID:	1
CORE	EGS Threshold2:	8
CORE	EGS Group2 ID:	2
CORE	EGS Threshold3:	12
CORE	EGS Group3 ID:	3
CORE	EGS Threshold4:	16
CORE	EGS Group4 ID:	4
CORE	EGS Group5 ID:	5
CORE GROUP 1	Group Name:	Propane
CORE GROUP 1	Flow Cust Min:	0
CORE GROUP 1	Flow Cust Max:	890
CORE GROUP 1	Flow Unit:	75
CORE GROUP 1	Temp Cust Min:	0
CORE GROUP 1	Temp Cust Max:	80
CORE GROUP 1	Temp Unit:	67
CORE GROUP 1	Pres Cust Min:	0
CORE GROUP 1	Pres Cust Max:	90
CORE GROUP 1	Pres Unit:	2
CORE GROUP 1	Line Size 0:	77.927
CORE GROUP 1	Line Size 1:	0
CORE GROUP 1	Line Units:	1
CORE GROUP 1	K Factor 1:	0
CORE GROUP 1	K Factor 2:	1
CORE GROUP 1	K Factor 3:	0
CORE GROUP 1	K Factor 4:	0
CORE GROUP 1	Flow Min SFPS:	5.3228
CORE GROUP 1	Flow Max SFPS:	108.95
CORE GROUP 1	Temp Min Deg F:	-50
CORE GROUP 1	Temp Max Deg F:	500
CORE GROUP 1	Pres Min PSIG:	0
CORE GROUP 1	Pres Max PSIG:	100
CORE GROUP 1	Std Density:	0.1255
CORE GROUP 1	Analog Out 1:	1
CORE GROUP 1	4 mA:	0
CORE GROUP 1	4 mA DAC1:	10474
CORE GROUP 1	20 mA:	90
CORE GROUP 1	20 mA DAC1:	54250
CORE GROUP 1	Namur1 (0=Off, 1=On):	1
CORE GROUP 1	Namur DAC1:	9380
CORE GROUP 1	Analog Out 2:	7
CORE GROUP 1	4 mA:	0
CORE GROUP 1	4 mA DAC2:	10500
CORE GROUP 1	20 mA:	500

CORE GROUP 1	20 mA DAC2:	50000
CORE GROUP 1	Namur2 (0=Off, 1=On):	0
CORE GROUP 1	Namur DAC2:	9450
CORE GROUP 1	Analog Out 3:	7
CORE GROUP 1	4 mA:	0
CORE GROUP 1	4 mA DAC3:	10500
CORE GROUP 1	20 mA:	500
CORE GROUP 1	20 mA DAC3:	50000
CORE GROUP 1	Namur3 (0=Off, 1=On):	0
CORE GROUP 1	Namur DAC3:	9450
CORE GROUP 1	EIA Factor1:	0
CORE GROUP 1	EIA Factor2:	2
CORE GROUP 1	EIA Factor3:	0.05
CORE GROUP 1	EIA Factor4:	0.1
CORE GROUP 1	FCS Process Data ID:	1
CORE GROUP 1	FCS All FEs or Individ.:	0
CORE GROUP 1	FCS Threshold1:	10
CORE GROUP 1	FCS Group1 ID:	1
CORE GROUP 1	FCS Threshold2:	20
CORE GROUP 1	FCS Group2 ID:	2
CORE GROUP 1	FCS Threshold3:	40
CORE GROUP 1	FCS Group3 ID:	3
CORE GROUP 1	FCS Threshold4:	50
CORE GROUP 1	FCS Group4 ID:	4
CORE GROUP 1	FCS Group5 ID:	5
FE 1	Version:	V 1.60
FE 1 GROUP 1	dR Min:	47.48
FE 1 GROUP 1	dR Max:	102.8
FE 1 GROUP 1	Cal Ref:	1189.69
FE 1 GROUP 1	tcs1p:	0.0009522
FE 1 GROUP 1	tcs1p0:	-0.030541
FE 1 GROUP 1	L Temp dR Gain:	0.9995031
FE 1 GROUP 1	L Temp dR Offset:	0.8854153
FE 1 GROUP 1	L Temp RefR Gain:	0.9997751
FE 1 GROUP 1	L Temp RefR Offset:	-0.9798821
FE 1 GROUP 1	DPoly(1,1):	0.1758943
FE 1 GROUP 1	DPoly(1,2):	0.9133858
FE 1 GROUP 1	DPoly(1,3):	-257.7477
FE 1 GROUP 1	DPoly(1,4):	23361.403
FE 1 GROUP 1	DPoly(1,5):	-7325.417
FE 1 GROUP 1	breakpoint:	0
FE 1 GROUP 1	H Temp dR Gain:	1.248457
FE 1 GROUP 1	H Temp dR Offset:	1.171136
FE 1 GROUP 1	H Temp RefR Gain:	1.248673
FE 1 GROUP 1	H Temp RefR Offset:	-1.048995
FE 1 GROUP 1	DPoly(2,1):	-24.614416
FE 1 GROUP 1	DPoly(2,2):	200.970275
FE 1 GROUP 1	DPoly(2,3):	-60305.54
FE 1 GROUP 1	DPoly(2,4):	7980455.9326
FE 1 GROUP 1	DPoly(2,5):	-3938943.862
FE 1 GROUP 1	0=Spline, 1=DPoly:	0
FE 1 GROUP 1	Number of Splines:	12
FE 1 GROUP 1	Spline X1:	5.080258
FE 1 GROUP 1	Spline X2:	7.814258
FE 1 GROUP 1	Spline X3:	11.47884
FE 1 GROUP 1	Spline X4:	14.69628
FE 1 GROUP 1	Spline X5:	24.17206
FE 1 GROUP 1	Spline X6:	29.93046

FE 1 GROUP 1	Spline X7:	43.8892
FE 1 GROUP 1	Spline X8:	53.78902
FE 1 GROUP 1	Spline X9:	72.30169
FE 1 GROUP 1	Spline X10:	81.36002
FE 1 GROUP 1	Spline X11:	90.53386
FE 1 GROUP 1	Spline X12:	108.9475
FE 1 GROUP 1	Spline X13:	0
FE 1 GROUP 1	Spline X14:	0
FE 1 GROUP 1	Spline X15:	0
FE 1 GROUP 1	Spline X16:	424.0097
FE 1 GROUP 1	Spline X17:	0
FE 1 GROUP 1	Spline X18:	0
FE 1 GROUP 1	Spline X19:	0
FE 1 GROUP 1	Spline X20:	0
FE 1 GROUP 1	Spline X21:	76
FE 1 GROUP 1	Spline X22:	80
FE 1 GROUP 1	Spline X23:	84
FE 1 GROUP 1	Spline X24:	88
FE 1 GROUP 1	Spline X25:	92
FE 1 GROUP 1	Spline X26:	96
FE 1 GROUP 1	Spline Y1:	102.8
FE 1 GROUP 1	Spline Y2:	91.7
FE 1 GROUP 1	Spline Y3:	81.82
FE 1 GROUP 1	Spline Y4:	75.59
FE 1 GROUP 1	Spline Y5:	68.17
FE 1 GROUP 1	Spline Y6:	64.13
FE 1 GROUP 1	Spline Y7:	58.21
FE 1 GROUP 1	Spline Y8:	55.51
FE 1 GROUP 1	Spline Y9:	52.36
FE 1 GROUP 1	Spline Y10:	50.8
FE 1 GROUP 1	Spline Y11:	49.49
FE 1 GROUP 1	Spline Y12:	47.48
FE 1 GROUP 1	Spline Y13:	0
FE 1 GROUP 1	Spline Y14:	0
FE 1 GROUP 1	Spline Y15:	0
FE 1 GROUP 1	Spline Y16:	32.054
FE 1 GROUP 1	Spline Y17:	0
FE 1 GROUP 1	Spline Y18:	0
FE 1 GROUP 1	Spline Y19:	0
FE 1 GROUP 1	Spline Y20:	0
FE 1 GROUP 1	Spline Y21:	21
FE 1 GROUP 1	Spline Y22:	18
FE 1 GROUP 1	Spline Y23:	15
FE 1 GROUP 1	Spline Y24:	12
FE 1 GROUP 1	Spline Y25:	9
FE 1 GROUP 1	Spline Y26:	6
FE 1 GROUP 1	Spline Z1:	0.00414592022128261
FE 1 GROUP 1	Spline Z2:	0.0273430041909284
FE 1 GROUP 1	Spline Z3:	-0.0396986412154984
FE 1 GROUP 1	Spline Z4:	0.20060176644267
FE 1 GROUP 1	Spline Z5:	-0.099224086339158
FE 1 GROUP 1	Spline Z6:	0.317182926925397
FE 1 GROUP 1	Spline Z7:	-0.0335553382440818
FE 1 GROUP 1	Spline Z8:	1.27944575571782
FE 1 GROUP 1	Spline Z9:	-0.593024525128956
FE 1 GROUP 1	Spline Z10:	1.00565957464572
FE 1 GROUP 1	Spline Z11:	1.39891331040173
FE 1 GROUP 1	Spline Z12:	1.25061301445323

FE 1 GROUP 1	Spline Z13:	0
FE 1 GROUP 1	Spline Z14:	0
FE 1 GROUP 1	Spline Z15:	0
FE 1 GROUP 1	Spline Z16:	4.98996155277627
FE 1 GROUP 1	Spline Z17:	0
FE 1 GROUP 1	Spline Z18:	0
FE 1 GROUP 1	Spline Z19:	0
FE 1 GROUP 1	Spline Z20:	0
FE 1 GROUP 1	Spline Z21:	0.029545391
FE 1 GROUP 1	Spline Z22:	0.018559536
FE 1 GROUP 1	Spline Z23:	0.065425703
FE 1 GROUP 1	Spline Z24:	-0.015682307
FE 1 GROUP 1	Spline Z25:	0.107693624
FE 1 GROUP 1	Spline Z26:	0.06331961
FE 1 GROUP 1	Htr (0=75mA, 1=90mA):	0
FE 1 GROUP 1	Htr 1 75mA DAC:	28856
FE 1 GROUP 1	Htr 1 90mA DAC:	34650
FE 1 GROUP 1	Htr 2 75mA DAC:	28816
FE 1 GROUP 1	Htr 2 90mA DAC:	34624
FE 1 GROUP 1	Act Exc DAC:	13086
FE 1 GROUP 1	Ref Exc DAC:	13085

HMI Menu Outline (v2.99)

- **Boot Screen**
- **Process Data Screen**
 - Percentage of Flow
 - Flowrate
 - Totalizer
 - Temperature
 - Pressure
 - Group
 - Group Name
- **Service**
 - Select Group
 - Password
 - 1. Air
 - 2. Gas
 - 3. Low Flow
 - 4. High Flow
 - 5. Upset
 - Alarm Ack
 - Blank
- **Diagnostics**
 - Show Faults
 - Blank
 - Self Test
 - FE 1 IDR
 - Password
 - FE2 IDR
 - Password
 - Raw Signal
 - Raw Signal FE1
 - F1 Raw Signal
 - RefR: 100.17
 - dR: 99.89
 - TCdR: 96.63
 - Temp: 32.0
 - Flow: 22.42
 - Raw Signal FE2
 - F2 Raw Signal (If Present)
 - Same as FE2
- **Set-up**
 - Instrument
 - Group 1
 - Flow: SFPS
 - Temp: Deg F
 - Pres: psi(a)
 - Name: Air
 - Restore
 - Pipe: Rect.
 - W: 1.0 in
 - H: 10.0 in
 - Display
 - Orientation
 - Select Display Orientation
 - Contrast
 - Select the HMI Display Contrast
 - Language
 - English
- **LoggerSDcard**
 - LoggerSCcard
 - Remove
 - Inserted
- **Device**
 - Serial No:
 - Sales Ord No:
 - Core: 1.06
 - HMI: 2.99
 - FE1: V1.60
 - FE2: V1.60
- **FE Control**
 - FE1: Online
 - Password
 - FE1 Control
 - Online
 - Offline
 - FE2: Offline
 - Password
 - FE2 Control
 - Online
 - Offline

Note: The HMI interface cannot access extended operation modes. Use the ST100 configuraton software application to set up an extended operating mode. See "Extended Operation Modes" on page 27.

Internal Delta-R Resistor Check (IDR) HMI Display Sequence

Hot Key

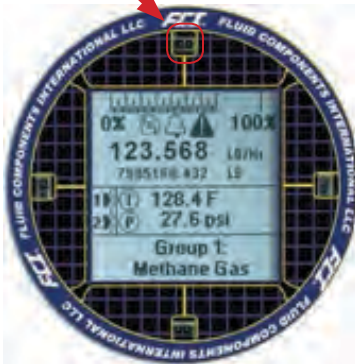

1. Normal Operation Display:
Select and hold the hot key for 3 seconds.



2. Select Diagnostics.

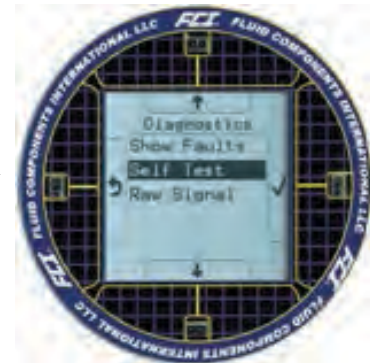

3. Select Self Test.



4. Select FE 1 for ST100 single point system.

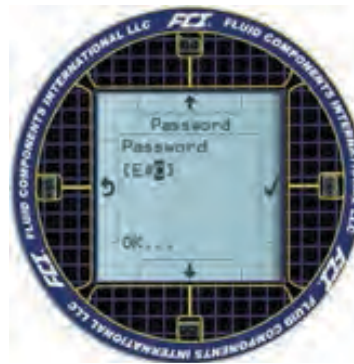

5. Input Password E#C



6. Select Password.

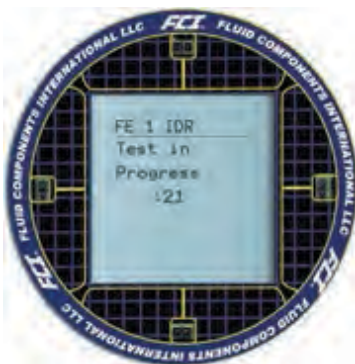

7. IDR Test is Running.

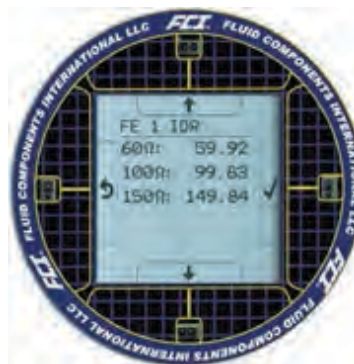

8. IDR Test is Complete.
Record values for comparison.

ST100 Configuration Software Menu Outline (v2.2.0.x)

Welcome to the ST100 Configuration Application

■ ST100

● **PROCESS DATA (IN CUSTOMER UNITS)**

- *FLOW (display)*
- *TEMPERATURE (display)*
- *PRESSURE (display)*
- *CALIBRATION GROUP (display)*
- *ALARMS AND FAULTS (display)*

● **BASIC SETUP**

— **Groups**

- *Select Group (frame)*
 - Active Group
 - 1: (radio button)
 - Restore Active Group from Factory (button)
- *Edit Group Name (frame)*
 - Group Name (text box)
- *Copy Active Group to Destination (frame)*
 - Destination Group (drop-down list)
 - Copy Active Group to Destination (button)

— **Units**

- *Units (frame)*
 - Flow Units (drop-down list)
 - Temperature Units (drop-down list)
 - Pressure Units (drop-down list)
- *Get from Device (button)*
- *Send to Device (button)*

— **Pipe Size**

- *Pipe Size (frame)*
 - Pipe Type (drop-down list)
 - Diameter (ID) (text box)
- *Get from Device (button)*
- *Send to Device (button)*

— **Alarms**

- *Alarm 1 (frame)*
 - Test enabled/disabled (drop-down list)
 - Greater Than/Less Than (drop-down list)
 - Threshold (text box)
 - Hysteresis \pm (text box)
 - On Delay (Seconds) (text box)
 - Off Delay (Seconds) (text box)
- *Alarm 2 (frame)*
 - Test enabled/disabled (drop-down list)
 - Greater Than/Less Than (drop-down list)
 - Threshold (text box)
 - Hysteresis \pm (text box)
 - On Delay (Seconds) (text box)

- Off Delay (Seconds) (text box)
- *Alarm 3 (frame)*
 - Test enabled/disabled (drop-down list)
 - Greater Than/Less Than (drop-down list)
 - Threshold (text box)
 - Hysteresis \pm (text box)
 - On Delay (Seconds) (text box)
 - Off Delay (Seconds) (text box)

- *Alarm 4 (frame)*
 - Test enabled/disabled (drop-down list)
 - Greater Than/Less Than (drop-down list)
 - Threshold (text box)
 - Hysteresis \pm (text box)
 - On Delay (Seconds) (text box)
 - Off Delay (Seconds) (text box)

- *Alarm 5 (frame)*
 - Test enabled/disabled (drop-down list)
 - Greater Than/Less Than (drop-down list)
 - Threshold (text box)
 - Hysteresis \pm (text box)
 - On Delay (Seconds) (text box)
 - Off Delay (Seconds) (text box)

- *Alarm 6 (frame)*
 - Test enabled/disabled (drop-down list)
 - Greater Than/Less Than (drop-down list)
 - Threshold (text box)
 - Hysteresis \pm (text box)
 - On Delay (Seconds) (text box)
 - Off Delay (Seconds) (text box)

- *Get from Device (button)*

- *Send to Device (button)*

— **SD Card Logging**

- *Secure Digital Card (frame)*
 - Remove Micro SD Card (button)
 - Insert Micro SD Card (button)

- *Logging (frame)*
 - Cancel Logging (button)
 - Start Logging (frame)
 - Start Now (check box)
 - Date (calendar date picker)
 - Time (spinner)
 - Sample Period (frame)
 - Hours : Mins : Secs (spinner)
 - Duration (frame)
 - Days (spinner)
 - Hours : Mins (spinner)

- Get from Device (button)
- Send to Device (button)
- *SD Card Log Files (frame)*
 - Show List of Log Files (button)
 - List of Log Files (Log File Name, Size) (list box)
 - Upload Selected Log File(s) (button)
- **Totalizer**
 - *Totalizer (frame)*
 - Totalizer enabled/disabled (check box)
 - Show/Hide Totalizer Value (check box)
 - Reset Totalizer to Zero (button)
 - *Get from Device (button)*
 - *Send to Device (button)*
- **Pressure Offset**
 - *Pressure (frame)*
 - Zero (button)
 - Offset (text box)
 - Apply Offset (button)
 - *Get from Device (button)*
- **ADVANCED SETUP**
 - **User Parameters**
 - *Customer Min/Max (frame)*
 - Cust. Min/Max Flow (text box, customer units)
 - Cust. Min/Max Temperature (text box, customer units)
 - Cust. Min/Max Pressure (text box, customer units)
 - *K Factor (frame)*
 - K Factor 1 (text box)
 - K Factor 2 (text box)
 - K Factor 3 (text box)
 - K Factor 4 (text box)
 - *Miscellaneous (frame)*
 - Density (text box)
 - Flow Damping (text box)
 - *Get from Device (button)*
 - *Send to Device (button)*
 - **Ethernet**
 - *Ethernet Settings (frame)*
 - Unit IP Address
 - Gateway Address
 - Subnet Mask
 - *Get from Device (button)*
 - *Send to Device (button)*
 - **Date and Time**
 - *Date and Time (frame)*
 - Date (calendar date picker)
 - Time (spinner)
 - *Get from Device (button)*
 - *Send to Device (button)*
- **Download Calibration**
 - *Get Calibration File (frame)*
 - File name path (text box & "Browse" button)
 - *Select Group For Download (frame)*
 - Group (drop-down list)
 - *Select FE For Download (frame)*
 - FE (drop-down list)
 - *Send to Device (button)*
- **CONFIGURATION**
 - **Output**
 - *Analog Output Board. (4-20mA, Freq., Pulse & HART) (radio button)*
 - Analog Output Selection (frame)
 - 4-20mA #1: (drop-down list)
 - ◇ 4mA @ Units ≤ (text box)
 - ◇ 20mA @ Units ≥ (text box)
 - 4-20mA #2: (drop-down list)
 - ◇ 4mA @ Units ≤ (text box)
 - ◇ 20mA @ Units ≥ (text box)
 - 4-20mA #3: (drop-down list)
 - ◇ 4mA @ Units ≤ (text box)
 - ◇ 20mA @ Units ≥ (text box)
 - Frequency (drop-down list)
 - ◇ Range: (drop-down list)
 - Pulse: (drop-down list)
 - ◇ X (multiplier): (drop-down list)
 - *Digital Output Board (Modbus, Foundation Fieldbus & Profibus) (radio button)*
 - Digital Output Selection (frame)
 - Digital Bus (drop-down list)
 - *Get from Device (button)*
 - *Send to Device (button)*
 - **4-20mA User**
 - *4-20mA #1*
 - Manual mA Output (text box)
 - Click to Output Manual (button)
 - NAMUR Enabled (check box)
 - Set NAMUR @ 3.6 mA (button)
 - Set NAMUR @ 21.0 mA (button)
 - NAMUR mA (text box)
 - NAMUR counts (text box)
 - Click to Test NAMUR (button)
 - *4-20mA #2*
 - Manual mA Output (text box)
 - *4-20mA #3*
 - Manual mA Output (text box)
 - Click to Output Manual (button)
 - *Get from Device (button)*

- *Send to Device (button)*
- **Modbus**
 - *Modbus (frame)*
 - Node ID: (text box)
 - Mode: (drop-down list)
 - Baud: (drop-down list)
 - Data Bits: (drop-down list)
 - Parity: (drop-down list)
 - Stop Bits: (drop-down list)
 - *Get from Device (button)*
 - *Send to Device (button)*
- **Extended Operational Mode**
 - *System Mode (frame)*
 - Toggle System Mode: (button)
 - *Extended Operational Mode (frame)*
 - Basic (radio button)
 - External Input Flow Adjust (EIA) (radio button)
 - External ST100 Flow Input (EFI) (radio button)
 - Auto FE Calibration Group Switching (FCS) (radio button)
 - External Control Group Switching (EGS) (radio button)
 - *Ext. Input Flow Adjust Setup (frame)*
 - Factor1: (text box)
 - Factor2: (text box)
 - Factor3: (text box)
 - Factor4: (text box)
 - *Ext. ST100 Flow Input Setup (frame)*
 - (Ext. ST100) Flow Units: (drop-down list)
 - (Ext. ST100) Flow Min (4mA): (text box)
 - (Ext. ST100) Flow Max (20mA): (text box)
 - *Get from Device (button)*
 - *Send to Device (button)*
 - *Set System Mode to “Running:” when Send (checkbox)*
- **Group Switch Setup**
 - *AUTO FE Calibration Group Switching Setup (frame)*
 - *External Control Group Switching Setup (frame)*
- **DIAGNOSTICS**
 - **Status**
 - *Faults, FE Status (scrollable text box)*
 - *Get from Device (button)*
 - **Fault Log**
 - *Fault log list (scrollable text box)*
 - *Get from Device (button)*
 - *Clear Fault Log (button)*
 - *Add to SD Card Log (button)*
 - **Scheduled Tasks**
 - *FE # (drop-down list)*
 - *Internal Delta-R Resistor Check (frame)*
 - Mode (drop-down list)
- Day, #days, DOW (spinner)
- Time (spinner)
- Run Check Now (button)
- *Get from Device (button)*
- *Send to Device (button)*
- **Test Logs**
 - *Test log list (scrollable text box)*
 - *Get from Device (button)*
 - *Clear Test Logs (button)*
 - *Add to SD Card Logs (button)*
- **FACTORY**
 - **Factory Parameters**
 - *Calibrated Min / Max (frame)*
 - Min & Max Flow (text boxes, Std feet per second)
 - Min & Max Temp (text boxes, Degrees F)
 - Min & Max Press (text boxes, psi (g))
 - *Get from Device (button)*
 - *Send to Device (button)*
 - **Identification**
 - *General (frame)*
 - Internal CORE S/W version (text box)
 - Customer name (text box)
 - Device CO (text box)
 - Device S/N (text box)
 - HMI S/W version (text box)
 - *Unit MAC Address (frame)*
 - MAC address (6 octets, spinner for each)
 - *Get from Device (button)*
 - *Send to Device (button)*
 - **4-20mA Factory**
 - *4-20mA #1 Settings (frame)*
 - Min DAC (4 mA) (spinner)
 - Max DAC (20 mA) (spinner)
 - Manual DAC Counts (spinner)
 - Click to Output Manual (button)
 - *4-20mA #2 Settings (frame)*
 - Min DAC (4 mA) (spinner)
 - Max DAC (20 mA) (spinner)
 - Manual DAC Counts (spinner)
 - Click to Output Manual (button)
 - *4-20mA #3 Settings (frame)*
 - Min DAC (4 mA) (spinner)
 - Max DAC (20 mA) (spinner)
 - Manual DAC Counts (spinner)
 - Click to Output Manual (button)
 - *4-20mA Input (frame)*
 - Raw A/D Counts (text box)
 - Gain (text box)

- 4-20mA Input (text box)
- Offset (text box)
- Click to Read 4-20mA Input (button)
- *Get from Device (button)*
- *Send to Device (button)*
- **Options**
 - *Optional Features (frame)*
 - HMI Display Present (check box)
 - *FE Configuration (frame)*
 - FEx (check box, x = 1-16)
 - Slot (drop-down list)
 - Pressure Sensor (drop-down list)
- **HART**
 - *HART Identification (frame)*
 - Electronics revision level
 - STAK Core S/W revision
 - Serial number,
 - Device S/W version (text box)
 - *Get from Device (button)*
 - *Send to Device (button)*
- **Memory**
 - *Memory Regions (frame)*
 - Device Params and User Groups: Erase (button)
 - Factory Groups: Erase (button)
 - HART Storage: Erase (button)
 - Modbus Storage: Erase (button)
- **FE 1**
 - **PROCESS DATA**
 - *RefR (display)*
 - *dR (display)*
 - *TcdR (display)*
 - *TEMPERATURE (display)*
 - *FLOW (display)*
 - *PRESSURE (display)*
 - **Parameter Reports**
 - **GROUP 1 (SCROLLABLE WINDOW)**
 - **GROUP 2 (SCROLLABLE WINDOW)**
 - **GROUP 3 (SCROLLABLE WINDOW)**
 - **GROUP 4 (SCROLLABLE WINDOW)**
 - **GROUP 5 (SCROLLABLE WINDOW)**

Instructions: Installing Ferrite Onto ST100 Series DC Power Cable

STEP 1

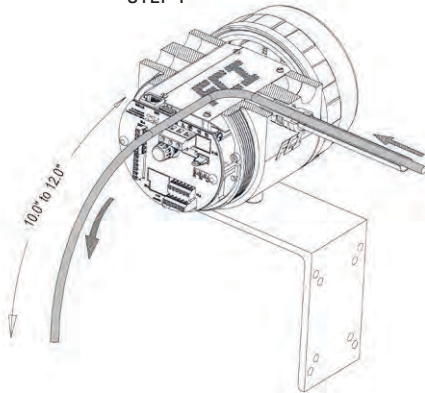

Insert DC power supply cable through enclosure conduit port as shown. Measure 10 to 12 inches beyond interface board.

STEP 2

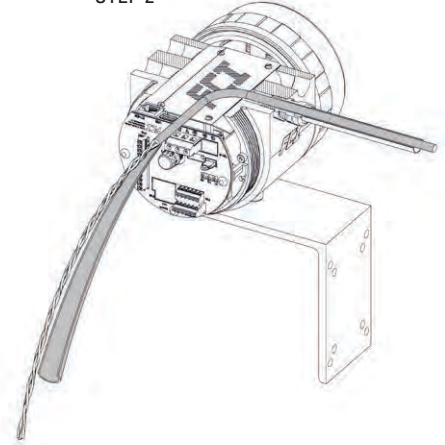

Slice open the jacket 10 to 12 inches and cut.

STEP 3

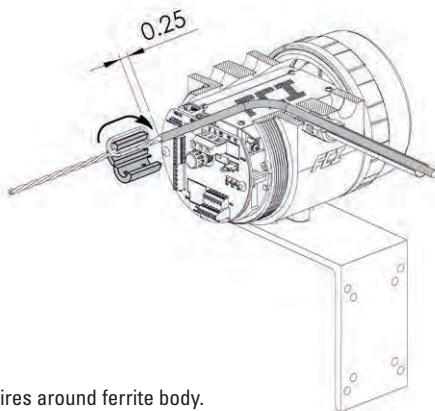

- Loop wires around ferrite body.
- Keep .25 inches from ferrite to edge of cable jacket as shown.
- Close ferrite.

STEP 4

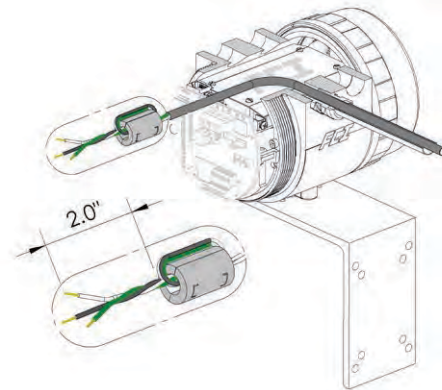

Cut wires 2 inches from edge of ferrite and strip ends as shown.

STEP 5

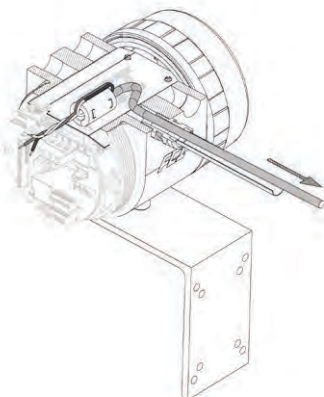

Slide ferrite over power supply cover while pulling on the power supply cable. Position ferrite face to coincide with edge of housing.

STEP 6

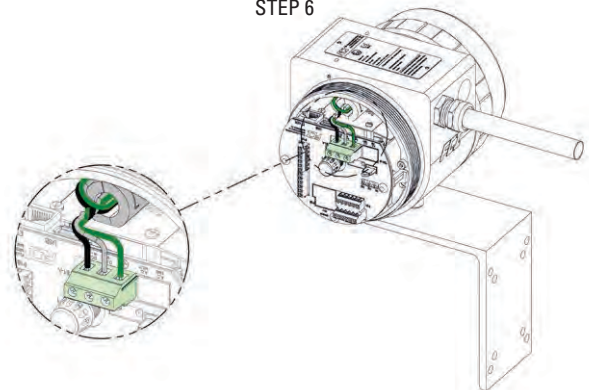

Insert and secure DC power supply wire leads to terminal connector as shown.

Intentionally Left Blank

APPENDIX D GLOSSARY

Abbreviations

Delta-R (DR)	Differential Resistance
Delta-T (DT)	Differential Temperature
DMM	Digital Multimeter
DPDT	Double Pole Double Throw
FCI	Fluid Components Intl
HTR	Heater
LED	Light Emitting Diode
POT	Potentiometer
RA	Return Authorization
RTD	Resistance Temperature Detector
SFPS	Standard Feet Per Second
SPDT	Single Pole Double Throw

Definitions

Active RTD	The sensing element that is heated by the heater. The active RTD is cooled due to increases in the process fluid flow rate or density (level sensing).
Differential resistance	
Delta-R (DR)	The difference in resistance between the active and reference RTDs.
Differential temperature	
Delta-T (DT)	The difference in temperature between the active and reference RTDs.
Heater (HTR)	The part of the sensing element that heats the active RTD.
Local enclosure	The enclosure attached to the sensing element. (Usually contains the control circuit and mounting socket.)
Reference RTD	The part of the sensing element that senses the process media temperature.
Remote enclosure	An optional protective enclosure for the control circuit. Used when the control circuit must be located away from the sensing element.
Resistance Temperature Detector (RTD)	A sensor whose resistance changes proportionally to temperature changes.
Sensing element	The transducer portion of the instrument. The sensing element produces an electrical signal that is related to the flow rate, density (level sensing), and temperature of the process media.
Thermowell	The part of the sensing element that protects the heater and RTDs from the process fluid.
Turndown	The ratio of the upper to lower flow rate values.

Intentionally Left Blank

APPENDIX E APPROVALS**EU DECLARATION OF CONFORMITY ST100 SERIES**

We, *Fluid Components International LLC*, located at 1755 La Costa Meadows Drive, San Marcos, California 92078-5115 USA, declare under our sole responsibility that the **ST100 Flowmeter Product Family**, to which this declaration relates, is in conformity with the following directives and specifications.

**Directive 2014/34/EU ATEX
IECEX Scheme**

Certified by FM Approvals LLC, NB Code 1725: 1151 Boston-Providence Turnpike, Norwood, MA 02062, USA

EC-Type Examination Certificates:

FM12ATEX0016X satisfies EN 60079-0: 2012, EN 60079-1: 2007, EN 60079-31: 2009, EN 60529 1991+A1:2000 requirements for use in hazardous areas.

Hazardous Areas Approval FM12ATEX0016X / IECEx FMG 12 0003X for:

II 2 G Ex d IIC T6...T1 Gb Ta = -40°C to +60°C

II 2 D Ex tb IIIC T85°C...T450°C Db Ta = -40°C to +60°C; IP67

Directive 2014/30/EU Electromagnetic Compatibility EMC

Immunity specification: EN 61000-6-2: 2005

Emissions specification: EN 61000-6-4: 2007, +A1: 2011

Directive 2014/35/EU Low Voltage

Electrical Safety Specification: EN 61010-1: 2010 +C1: 2011 + C2: 2013

Directive 2016/68/EU Pressure Equipment (PED)

The ST100 (Insertion Style) models do not have a pressure bearing housing and are therefore not considered as pressure equipment by themselves according to article 2, paragraph 5.

The ST100L (In-line Style) models are in conformity with Sound Engineering Practices as defined in the Pressure Equipment Directive (PED) 2014/68/EU article 4, paragraph 3.

Directive 2011/65/EU RoHS 2

The ST100 Product Family is in conformity with Directive 2011/65/EU of the European Parliament and of the Council of 8 June 2011 on the restriction of the use of certain hazardous substances in electrical and electronic equipment.

*Issued at San Marcos, California USA
September 2016*

 Manuel Liong
2016.09.07 09:07:47
-07'00'

Manuel Liong, Qualifications Engineer

Flow/Liquid Level/Temperature Instrumentation

Visit FCI on the Worldwide Web: www.fluidcomponents.com

1755 La Costa Meadows Drive, San Marcos, California 92078 USA 760-744-6950 • 800-854-1993 • 760-736-6250
European Office: Persephonestraat 3-01 5047 TTTilburg – The Netherlands – Phone 31-13-5159989 • Fax 31-13-5799036

Doc no. 23EN000024G

Intentionally Left Blank

Safety Instructions for the use the ST100 Series flow meter in Hazardous Areas Approval FM12ATEX0016X/IECEX FMG12.0003X for:

II 2 G for Gas protection Ex d IIC T6...T1

II 2 D for Dust protection Ex tb IIIC T85°C...T450°C; IP67

The ST100 Series consist of a sensing element and associated integral or remote mounted electronics mounted in a type "d" flameproof enclosure.

Relation between ambient temperature, process temperature and temperature class is as follows:

Ambient Temperature Range (Ta):	Electronic enclosure: T6/ T85°C for an ambient temperature range of -40°C to +40°C Electronic enclosure: T5/ T100°C for a ambient temperature range of -40°C to +60°C
Standard Configuration, Process Temperature Range (Tp):	Probe: T4/ T135°C for a process temperature range of -40°C to +65°C Probe: T3/ T200°C for a process temperature range of -40°C to +115°C Probe: T2/ T300°C for a process temperature range of -40°C to +177°C Probe: T1/ T450°C for a process temperature range of -40°C to +365°C
AST Configuration, Process Temperature Range (Tp):	Probe: T4/ T135°C for a process temperature range of -40°C to +89°C Probe: T3/ T200°C for a process temperature range of -40°C to +154°C Probe: T2/ T300°C for a process temperature range of -40°C to +254°C Probe: T1/ T450°C for a process temperature range of -40°C to +404°C

Electrical data: Power supply: 85 to 265 VAC, 50/60 Hz, 13.1 watts max.; 24 VDC, 13.2 watts max.

Dansk	Sikkerhedsforskrifter	Italiano	Normative di sicurezza
Deutsch	Sicherheitshinweise	Nederlands	Veiligheidsinstructies
English	Safety instructions	Português	Normas de segurança
Ἦπ	Ἦποδειἕεις ασφαλειαἕ	Español	Instrucciones de seguridad
Suomi	Turvallisuusohjeet	Svenska	Säkerhetsanvisningar
Français	Consignes de sécurité		

DK Dansk - Sikkerhedsforskrifter

Disse sikkerhedsforskrifter gælder for Fluid Components, gennemstrømningsmåleren i ST100 Series for EF-typeafprøvningsattest-nr. FM12ATEX0016X/IECEX FMG12.0003X (attestens nummer på typeskiltet) til anvendelse i en potentiel eksplosiv atmosfære i kategori II 2 GD.

- 1) Ex-anlæg skal opstilles af specialiseret personale.
- 2) ST100 Series skal jordforbindes.
- 3) Klemmerne og elektronikken er monteret i et hus, som er beskyttet af en flammebestandig og tryktæt med følgende noter:
 - Gevindspalten mellem huset og låget er på en sådan måde, at ild ikke kan brede sig inden i det.
 - Ex-"d" tilslutningshuset er forsynet med et 1/2" NPT og/eller M20x1.5 kabelindføring til montering af en Ex-"d" kabelindføring, der er attesteret iht. IEC/EN 60079-1.
 - Det er vigtigt at sørge for, at forsyningsledningen er uden spænding eller eksplosiv atmosfære ikke er til stede, før låget åbnes og når låget er åbent på "d" huset (f.eks. ved tilslutning eller servicearbejde).
 - Låget på „d” huset skal være skruet helt ind, når apparatet er i brug. Det skal sikres ved at dreje en af låseskruerne på låget ud.
- 4) Henvend dig til producenten, hvis du har brug for oplysninger om målene på de flammebestandige led.
- 5) Den malede overflade på gennemstrømningsmåleren i ST100 Series kan indeholde elektrostatisk udladning og blive en antændelseskilde ved anvendelser med en lav relativ fugtighed < 30 % relativ fugtighed, hvis den malede overflade er relativt fri for overfladekontaminanter, som fx snavs, støv eller olie. Rengøring af den malede overflade må kun udføres med en fugtig klud.
- 6) Det interne batteri må ikke udskiftes i en eksplosiv gasholdig atmosfære.

D A Deutsch - Sicherheitshinweise

Diese Sicherheitshinweise gelten für die Fluid Components, ST100 Series flow meter gemäß der EG-Baumusterprüfbescheinigung Nr. FM12ATEX0016X/IECEX FMG12.0003X (Bescheinigungsnummer auf dem Typschild) der Kategorie II 2 GD.

- 1) Die Errichtung von Ex-Anlagen muss grundsätzlich durch Fachpersonal vorgenommen werden.
- 2) Der ST100 Series muß geerdet werden.
- 3) Die Klemmen und Elektronik sind in einem Gehäuse in der Zündschutzart druckfeste Kapselung („d“) eingebaut.
 - Der Gewindespalt zwischen dem Gehäuse und dem Deckel ist ein zünddurchschlagsicherer Spalt.
 - Das Ex-“d“ Anschlussgehäuse besitzt ein 1/2“ NPT und/oder M20x1.5 Gewinde für den Einbau einer nach IEC/EN 60079-1 bescheinigten Ex-“d“ Kabeleinführung.
 - Es ist sicherzustellen, dass vor dem Öffnen und bei geöffnetem Deckel des „d“ Gehäuses (z.B. bei Anschluss oder Service- Arbeiten) entweder die Versorgungsleitung spannungsfrei oder keine explosionsfähige Atmosphäre vorhanden ist.
 - Der Deckel des “d“ Gehäuses muss im Betrieb bis zum Anschlag hineingedreht sein. Er ist durch eine der Deckelarretierungsschrauben zu sichern.
- 4) Wenden Sie sich an den Hersteller, wenn die Dimensionsinformationen zu den flammbeständigen Spalten erforderlich sind.
- 5) Die lackierte Oberfläche des ST100 Series flow meter kann elektrostatisch aufgeladen sein und in Anwendungen mit einer niedrigen relativen Feuchtigkeit von weniger als 30 %, bei denen die lackierte Oberfläche relativ frei von Flächenverunreinigungen wie Schmutz, Staub oder Fett ist, zu einer Zündquelle werden. Die lackierte Oberfläche sollte nur mit einem feuchten Tuch gereinigt werden.
- 6) Ersetzen Sie die interne Batterie nicht in einer explosionsfähigen Gasatmosphäre.

GB IRL English - Safety instructions

These safety instructions are valid for the Fluid Components, ST100 Series flow meter to the EC type approval certificate no FM12ATEX0016X/IECEX FMG12.0003X (certificate number on the type label) for use in potentially explosive atmospheres in Category II 2 GD.

- 1) The installation of Ex-instruments must be made by trained personnel.
- 2) The ST100 Series must be grounded.
- 3) The terminals and electronics are installed in a flame proof and pressure-tight housing with following notes:
 - The gap between the housing and cover is an ignition-proof gap.
 - The Ex-“d“ housing connection has a 1/2” NPT and/or M20x1.5 cable entry for mounting an Ex-d cable entry certified acc. to IEC/EN 60079-1.
 - Make sure that before opening the cover of the Ex”d“ housing, the power supply is disconnected or there is no explosive atmosphere present (e.g. during connection or service work).
 - During normal operation: The cover of the “d“ housing must be screwed in completely and locked by tightening one of the cover locking screws.
- 4) Consult the manufacturer if dimensional information on the flameproof joints is necessary.
- 5) The painted surface of the ST100 Series Flow Meter may store electrostatic charge and become a source of ignition in applications with a low relative humidity < 30% relative humidity where the painted surface is relatively free of surface contamination such as dirt, dust, or oil. Clean the painted surface using a damp cloth only.
- 6) Do not replace internal battery when an explosive gas atmosphere is present.

GR Υποδείξεις ασφαλείας

Αυτές οι οδηγίες ασφαλείας ισχύουν για τα ροόμετρα της Fluid Components τύπου ST100 Series που φέρουν Πιστοποιητικό Εγκρίσεων Ευρωπαϊκής Ένωσης, με αριθμό πιστοποίησης FM12ATEX0016X/IECEX FMG12.0003X (ο αριθμός πιστοποίησης βρίσκεται πάνω στην ετικέτα τύπου του οργάνου) για χρήση σε εκρηκτικές ατμόσφαιρες της κατηγορίας II 2 GD.

- 1) Η εγκατάσταση των οργάνων με αντιαεκρηκτική προστασία πρέπει να γίνει από εξειδικευμένο προσωπικό.
- 2) Το όργανο τύπου ST100 Series πρέπει να είναι γειωμένο.
- 3) Τα τερματικά ηλεκτρικών συνδέσεων (κλέμες) και τα ηλεκτρονικά κυκλώματα είναι εγκατεστημένα σε περίβλημα αντιαεκρηκτικό και αεροστεγές σύμφωνα με τις ακόλουθες παρατηρήσεις:
 - Το κενό ανάμεσα στο περίβλημα και στο κάλυμμα είναι τέτοιο που αποτρέπει την διάδοση σπινθήρα.
 - Το αντιαεκρηκτικό περίβλημα "Ex-d" διαθέτει ανοίγματα εισόδου καλωδίου με διάμετρο ½" NPT ή/και M 20 x1,5 , κατάλληλα για τοποθέτηση υποδοχής αντιαεκρηκτικού καλωδίου πιστοποιημένου κατά IEC/EN 60079-1
 - Βεβαιωθείτε ότι πριν ανοίξετε το κάλυμμα του αντιαεκρηκτικού περιβλήματος "Ex-d", η τάση τροφοδοσίας είναι αποσυνδεδεμένη ή ότι δεν υφίσταται στην περιοχή εκρηκτική ατμόσφαιρα (π.χ. κατά τη διάρκεια της σύνδεσης ή των εργασιών συντήρησης)
 - Κατά τη διάρκεια ομαλής λειτουργίας: Το κάλυμα του αντιαεκρηκτικού περιβλήματος "d" πρέπει να είναι καλά βιδωμένο και ασφαλισμένο, σφίγγοντας μία από τις βίδες ασφαλείας του περιβλήματος.
- 4) Εάν απαιτούνται πληροφορίες για τις διαστάσεις των αντιπυρικών συνδέσμων, απευθυνθείτε στον κατασκευαστή.
- 5) Στην βαμμένη επιφάνεια του ροόμετρου ST100 Series ενδέχεται να δημιουργείται ηλεκτροστατική φόρτιση κι αυτό να αποτελεί πηγή ανάφλεξης κατά την εφαρμογή σε συνθήκες χαμηλής σχετικής υγρασίας (<30%) όπου η βαμμένη επιφάνεια είναι σχετικά ελεύθερη από ρύπανση, όπως ακαθαρσίες, σκόνη ή λάδια. Ο καθαρισμός της βαμμένης επιφάνειας πρέπει να πραγματοποιείται μόνο με νοτισμένο πανί.
- 6) Μην αντικαθιστάτε την εσωτερική μπαταρία σε ατμόσφαιρα με εκρηκτικά αέρια.

FIN Suomi - Turvallisuusohjeet

Nämä turvallisuusohjeet koskevat Fluid Components, ST100 Series -virtausmittaria, tyyppitarkastustodistuksen nro. FM12ATEX0016X/IECEX FMG12.0003X (todistuksen numero näkyy tyyppikilvestä) käytettäessä räjähdysvaarallisissa tiloissa luokassa II 2GD.

- 1) Ex-laitteet on aina asennettava ammattihenkilökunnan toimesta.
- 2) ST100 Series on maadoitettava.
- 3) Syöttöjännitteen kytkemisessä tarvittavat liittimet ja elektroniikka on asennettu koteloon, jonka rakenne kestää räjähdyspaineen seuraavin lisäyksin:
 - Kotelon ja kannen välissä on räjähdyspurkausväli.
 - Ex-d liittäntäkotelossa on 1/2" NPT ja/tai M20x1.5 kierre IEC/EN 60079-1 mukaisen Ex-d kaapeliläpiviennin asennusta varten
 - Kun "d"-kotelon kansi avataan (esim. liitäntän tai huollon yhteydessä), on varmistettava, että joko syöttöjohto on jännitteetön tai ympäristössä ei ole räjähtäviä aineita.
 - "d"-kotelon kansi on kierrettävä aivan kiinni käytön yhteydessä ja on varmistettava kiertämällä yksi kannen lukitusruuveista kiinni.
- 4) Mikäli räjähdyspaineen kestävästä liitoksista tarvitaan mittatietoja, ota yhteys valmistajaan.
- 5) ST100 Series -virtausmittarin maalatussa pinnassa saattaa olla sähköstaattista varausta, mikä voi aiheuttaa räjähdyskäyttökohteissa, joiden suhteellinen kosteus on alhainen eli alle 30 %, kun maalatulla pinnalla ei ole huomattavaa likaa, pölyä tai öljyä. Maalatun pinnan saa puhdistaa ainoastaan kostealla liinalla.
- 6) Älä vaihda sisäistä akkua kaasuräjähdyksivaarallisissa tiloissa.

F B L Consignes de sécurité

Ces consignes de sécurité sont valables pour le modèle série ST100 de la société Fluid Components (FCI) conforme au certificat d'épreuves de type FM12ATEX0016X/IECEX FMG12.0003X (numéro du certificat sur l'étiquette signalétique) conçu pour les applications dans lesquelles un matériel de la catégorie II2GD est nécessaire.

- 1) Seul un personnel spécialisé et qualifié est autorisé à installer le matériel Ex.
- 2) Les ST100 Series doivent être reliés à la terre.
- 3) Les bornes pour le branchement de la tension d'alimentation et l'électronique sont logées dans un boîtier à enveloppe antidéflagrante avec les notes suivantes :
 - Le volume entre le boîtier et le couvercle est protégé en cas d'amorçage.
 - Le boîtier de raccordement Ex-d dispose d'un filetage 1/2" NPT et/ou M20x1.5 pour le montage d'un presse-étoupe Ex-d certifié selon la IEC/EN 60079-1.
 - Avant d'ouvrir le couvercle du boîtier « d » et pendant toute la durée où il le restera ouvert (pour des travaux de raccordement, d'entretien ou de dépannage par exemple), il faut veiller à ce que la ligne d'alimentation soit hors tension ou à ce qu'il n'y ait pas d'atmosphère explosive.
 - Pendant le fonctionnement de l'appareil, le couvercle du boîtier « d » doit être vissé et serré jusqu'en butée. La bonne fixation du couvercle doit être assurée en serrant une des vis d'arrêt du couvercle.
- 4) Consulter le fabricant si les dimensions des joints ignifugés sont nécessaires.
- 5) La surface peinte du débitmètre série ST100 peut contenir une charge électrostatique et devenir une source d'inflammation pour les applications où l'humidité relative est faible (< 30 %) et où la surface peinte ne présente pas de souillures (poussière, saleté, huile). Les surfaces peintes ne doivent être nettoyées qu'à l'aide d'un chiffon humide.
- 6) Ne pas remplacer la batterie interne en présence d'un gaz explosif.

I Italiano - Normative di sicurezza

Queste normative di sicurezza si riferiscono ai misuratori di portata serie ST100 della Fluid Components. Secondo il certificato CE di prova di omologazione n° FM12ATEX0016X/IECEX FMG12.0003X (numero del certificato sulla targhetta d'identificazione), essi sono idonei all'impiego in atmosfere potenzialmente esplosive di categoria II 2 GD.

- 1) L'installazione di sistemi Ex deve essere eseguita esclusivamente da personale specializzato.
- 2) I misuratori serie ST100 devono essere collegati a terra.
- 3) I morsetti per il collegamento e l'elettronica sono incorporati in una custodia a prova di esplosione ("d") con le seguenti note:
 - L'interstizio tra la custodia e il coperchio è a prova di innesco.
 - La custodia di collegamento Ex-d è dotata di un NTP da 3,81 cm e/o un passacavo 20x1,5 per il montaggio di un passacavo omologato Ex-d secondo IEC/EN 60079-1.
 - Prima di aprire il coperchio della custodia "d" (per es. durante operazioni di collegamento o di manutenzione) accertarsi che l'apparecchio sia disinserito o che non si trovi in presenza di atmosfere esplosive.
 - Durante le operazioni ordinarie, il coperchio della custodia "d" deve essere avvitato e chiuso avvitando una delle viti di chiusura fino all'arresto.
- 4) Consultare il produttore per ottenere informazioni sulle dimensioni dei giunti non infiammabili.
- 5) La superficie pitturata del misuratore di portata serie ST100 potrebbe trattenere carica elettrostatica e diventare una fonte infiammabile in applicazioni con un'umidità relativa bassa < 30%, dove la superficie pitturata è relativamente libera da sostanze contaminanti come polvere, sporcizia o olio. La superficie pitturata deve essere pulita esclusivamente con un panno umido.
- 6) Non sostituire la batteria interna in caso di presenza di gas esplosivi nell'atmosfera.

NL**B****Nederlands - Veiligheidsinstructies**

Deze veiligheidsinstructies gelden voor de flow meter uit de ST100-serie van Fluid Components (FCI) overeenkomstig het EG-typegoedkeuringscertificaat met nummer FM12ATEX0016X/IECEX FMG12.0003X (nummer van het certificaat op het typeplaatje) voor gebruik in een explosieve atmosfeer volgens Categorie II 2GD.

- 1) De installatie van Ex-instrumenten dient altijd te geschieden door geschoold personeel.
- 2) De ST100-serie moet geaard worden.
- 3) De aansluitklemmen en de elektronica zijn ingebouwd in een drukvaste behuizing met de volgende opmerkingen:
 - De schroefdraadspleet tussen de behuizing en het deksel is een ontstekingsdoorslagveilige spleet.
 - De Ex-'d' aansluitbehuizing heeft een 1/2" of een M20x1.5 schroefdraad voor aansluiting van een volgens IEC/EN 60079-1 goedgekeurde Ex-'d' kabelinvoer.
 - De atmosfeer mag niet explosief zijn of de stroomtoevoer moet zijn uitgeschakeld, voordat het deksel van de Ex-'d' behuizing wordt geopend (bijvoorbeeld bij aansluit- of servicewerkzaamheden).
 - Het deksel van de 'd' behuizing moet bij normaal bedrijf zijn vastgeschroefd tot aan de aanslag. Het deksel moet zijn vergrendeld door een van de dekselborgschroeven aan te draaien.
- 4) Raadpleeg de fabrikant als u dimensionale informatie over de drukvaste verbindingen nodig hebt.
- 5) Er kan sprake zijn van een elektrostatische lading op het gelakte oppervlak van de flow meter uit de ST100-serie. Deze lading kan een ontstekingsbron vormen bij toepassingen met een lage relatieve vochtigheid (< 30% relatieve vochtigheid), wanneer het gelakte oppervlak relatief weinig is verontreinigd met bijvoorbeeld vuil, stof of olie. Het gelakte oppervlak mag alleen worden gereinigd met een vochtige doek.
- 6) Vervang de interne accu niet in een explosieve gasatmosfeer.

P**Português - Normas de segurança**

Estas instruções de segurança são válidas para o caudalímetro Fluid Components da série ST100, de acordo com o certificado de aprovação nº FM12ATEX0016X/IECEX FMG12.0003X (numero do certificado na etiqueta de tipo), para utilizar em atmosferas potencialmente explosivas da categoria II 2 GD.

- 1) A instalação de equipamentos Ex deve ser realizada por pessoal qualificado.
- 2) A Série ST100 tem de ser ligada à terra.
- 3) Os terminais e a eletrónica são instalados num alojamento com proteção contra ignição e estanque em termos de pressão com as seguintes notas:
 - A folga entre o alojamento e a tampa é uma folga à prova de ignição.
 - A ligação do alojamento Ex-"d" tem uma entrada de cabo de 1/2" NPT e/ou M20x1,5 para a montagem de um cabo Ex-"d" certificado de acordo com a norma IEC/EN 60079-1.
 - Assegure, antes de abrir a tampa do alojamento Ex "d", que a fonte de alimentação está desligada ou que não está presente uma atmosfera explosiva (por exemplo, durante o trabalho de ligação ou assistência).
 - Durante o funcionamento normal: a tampa do alojamento "d" deve estar completamente aparafusada e bloqueada apertando um dos parafusos de bloqueio da tampa.
- 4) Consulte o fabricante se for necessária informação sobre as dimensões das junções à prova de chamas.
- 5) A superfície pintada do caudalímetro da série ST100 pode acumular cargas eletrostáticas e tornar-se numa fonte de ignição em aplicações com uma humidade relativa baixa < 30%, onde a superfície pintada está relativamente livre de contaminação da superfície com, por exemplo, sujidade, poeira ou óleo. A limpeza da superfície pintada deverá ser efetuada apenas com um pano humedecido.
- 6) Não substitua a bateria interna quando estiver presente uma atmosfera com fases explosivos.

E Español - Instrucciones de seguridad

Estas instrucciones de seguridad son de aplicación para el modelo Serie ST100 de Fluid Components, según la certificación CE de N° FM12ATEX0016X/IECEX FMG12.0003X para aplicaciones en atmósferas potencialmente explosivas según la categoría II 2 GD (el número decertificación se indica sobre la placa informativa del equipo).

- 1) La instalación de equipos Ex tiene que ser realizada por personal especializado.
- 2) Los Serie ST100 deben ser conectados a tierra.
- 3) Los bornes de conexión y la unidad electrónica están montados dentro de una caja con protección ignífuga y resistente a la presión, considerándo los siguientes puntos:
 - La holgura entre la caja y su tapa es a prueba contra ignición.
 - La conexión eléctrica de la caja Ex-"d" posee una rosca NPT de 1/2" y/o una entrada de cable M20x1.5, dónde deberán conectar una entrada de cable Ex-"d" según lo establecido por las normas IEC/EN 60079-1.
 - Antes de la apertura de la tapa de la caja Ex-"d" (p. ej. durante los trabajos de conexión o de puesta en marcha), asegúrese de que el equipo se halle sin tensión o que no exista presencia de atmósfera explosiva.
 - Durante el funcionamiento normal: la tapa de la caja "d" tiene que estar cerrada, roscada hasta el tope, debiéndose asegurar apretando los tornillos de bloqueo.
- 4) Consulte con el fabricante si es necesario incluir la información dimensional en las juntas ignífugas.
- 5) Es posible que la superficie pintada del medidor de flujo Serie ST100 almacene carga electrostática y se convierta en una fuente de ignición en aplicaciones con baja humedad relativa < 30% cuando la superficie pintada está relativamente libre de contaminación en superficie, como por ejemplo suciedad, polvo o aceite. La limpieza de la superficie pintada debe realizarse solo con un paño húmedo.
- 6) No reemplace la batería interna cuando se encuentre en una atmósfera con presencia de gas explosivo.

S Svenska - säkerhetsanvisningar

Säkerhetsanvisningarna gäller för Fluid Componentets flödesmätare, typ ST100 Series, enligt EG-typgodkännandeintyg nr FM12ATEX0016X/IECEX FMG12.0003X (intygsnumret återfinns på typskylten) för användning i explosiv gasblandning i kategori II 2 GD.

- 1) Installation av Ex-klassade instrument måste alltid utföras av fackpersonal.
- 2) ST100 Series måste jordas.
- 3) Anslutningsklämmorna och elektroniken är inbyggda i en explosions- och trycktät kapsling. Observera följande:
 - Spalten mellan kapslingen och lockets gänga är explosionstät.
 - Ex-d-kapslingen har en 1/2" NPT- och/eller M20x1,5-gänga för montering av en IEC/SS-EN 60079-1-typgodkänd Ex-d-kabelförskruvning
 - När Ex-d-kapslingens lock är öppet (t.ex. vid inkoppling - eller servicearbeten) ska man se till att enheten är spänningslös eller att ingen explosiv gasblandning förekommer.
 - Under drift måste Ex-d-kapslingens lock vara fastskruvat till anslaget. Skruva i en av lockets låsskruvar för att låsa det. man i en av lockets insex låsskruvar.
- 4) Hör med tillverkaren om måttuppgifter om de brandsäkra fogarna behövs.
- 5) Den lackade ytan på ST100-flödesmätaren kan lagra elektrostatisk laddning och bli en antändningskälla vid tillämpningar i en låg relativ luftfuktighet (< 30 %) om den lackade ytan i stort sett är ren från ytkontaminering som smuts, damm eller olja. Den lackade ytan får endast rengöras med en fuktad trasa.
- 6) Byt inte ut det interna batteriet om en explosiv atmosfär föreligger.

APPENDIX F CUSTOMER SERVICE

Customer Service/Technical Support

FCI provides full in-house technical support. Additional technical representation is also provided by FCI field representatives. Before contacting a field or in-house representative, perform the troubleshooting techniques outlined in this document.

By Mail

Fluid Components International LLC
1755 La Costa Meadows Dr.
San Marcos, CA 92078-5115 USA
Attn: Customer Service Department

By Phone

Contact the area FCI regional representative. If a field representative is unable to be contacted or if a situation is unable to be resolved, contact the FCI Customer Service Department toll free at 1 (800) 854-1993.

By Fax

To describe problems in a graphical or pictorial manner, send a fax including a phone or fax number to the regional representative. Again, FCI is available by facsimile if all possibilities have been exhausted with the authorized factory representative. Our Fax number is 1 (760) 736-6250; it is available 7 days a week, 24 hours a day.

By E-Mail

FCI Customer Service can be contacted by e-mail at: techsupport@fluidcomponents.com.

Describe the problem in detail making sure a telephone number and best time to be contacted is stated in the e-mail.

International Support

For product information or product support outside the contiguous United States, Alaska, or Hawaii, contact your country's FCI International Representative or the one nearest to you.

After Hours Support

For product information visit FCI at www.fluidcomponents.com. For product support call 1 (800) 854-1993 and follow the prerecorded instructions.

Point of Contact

The point of contact for service, or return of equipment to FCI is your authorized FCI sales/service office. To locate the office nearest you, go to www.fluidcomponents.com.

Warranty Repairs or Returns

FCI prepays ground transportation charges for return of freight to the customer's door. FCI reserves the right to return equipment by the carrier of our choice.

International freight, handling charges, duty/entry fees for return of equipment are paid by the customer.

Non-Warranty Repairs or Returns

FCI returns repaired equipment to the customer either collect or prepaid and adds freight charges to the customer invoice.

Extended Warranty

An extended warranty is available. Contact the factory for more information.

Return to Stock Equipment

The customer is responsible for all shipping and freight charges for equipment that is returned to FCI stock from the customer site. These items will not be credited to the customer's account until all freight charges are cleared, along with applicable return to stock charges, from the credit invoice. (Exceptions are made for duplicate shipments made by FCI.)

If any repair or return equipment is received at FCI, freight collect, without prior factory consent, FCI bills the sender for these charges.

Field Service Procedures

Contact an FCI field representative to request field service.

A field service technician is dispatched to the site from either the FCI factory or one of the FCI representative offices. After the work is complete, the technician completes a preliminary field service report at the customer site and leaves a copy with the customer.

Following the service call, the technician completes a formal, detailed service report. The formal report is mailed to the customer after the technician's return to the factory or office.

Field Service Rates

All field service calls are billed at the prevailing rates as listed in the FCI Price Book unless previous arrangements have been made with the FCI Customer Service Manager.

Customers are charged for all travel expenses including airfare, auto rental, meals and lodging. In addition, the customer shall pay all costs of transporting parts, tools or goods to and from the job site. Invoicing travel time, field service work and other expenses will be performed by FCI's Accounting Department.



RA # _____

1755 La Costa Meadows Drive, San Marcos, CA 92078-5115 USA
760-744-6950 / 800-854-1993 / Fax: 760-736-6250
Web Site: www.fluidcomponents.com
E-mail: techsupport@fluidcomponents.com

Return Authorization Request

1. Return Customer Information

Returning Company's Name: _____ Phone# _____

Return Contact Name: _____ Fax # _____

Email Address: _____

2. Return Address

Bill To: _____ Ship To: _____

3. Mandatory End User Information

Contact: _____ Company: _____ Country: _____

4. Return Product Information

Model No: _____ Serial No(s): _____

Failure Symptoms (Detailed Description Required): _____

What Trouble Shooting Was Done Via Phone or Field Visit by FCI: _____

FCI Factory Technical Service Contact: _____

- 5. Reason For Return**
- Sensor Element
 - Electronics
 - As Found Testing
 - Credit
 - Recalibrate (New Data)
 - Recalibrate (Most Recent Data)
 - Other

(Note: A new Application Data Sheet (ADS) must be submitted for all recalibrations and re-certifications)

- 6. Payment Via**
- Faxed Purchase Order
 -
 -

(Note: A priced quotation is provided for all Non-Warranty repairs after equipment has been evaluated. All Non-Warranty repairs are subject to a minimum evaluation charge of \$250.00)

Factory Return Shipping Address:

Fluid Components International LLC
1755 La Costa Meadows Drive
San Marcos, CA 92078-5115
Attn: Repair Department
RA # _____



The following Return Authorization Request form and Decontamination Statement **MUST be completed, signed and faxed back to FCI before** a Return Authorization Number will be issued. The signed Decontamination Statement and applicable MSDS Sheets **must be included with the shipment**. FCI will either fax, email or telephone you with the Return Authorization Number upon receipt of the signed forms.

Packing Procedures

1. **Electronics** should be wrapped in an **anti-static** or **static-resistant** bag, then wrapped in protective bubble wrap and surrounded with appropriate dunnage* in a box. Instruments weighing **more than 50 lbs., or extending more than four feet**, should be secured in wooden crates by bolting the assemblies in place.
2. **The sensor head must be protected** with pvc tubing, or retracted the full length of the probe, locked and secured into the Packing Gland Assembly (cap screws tightened down).
3. FCI can supply crates for a nominal fee.
4. No more than **four (4)** small units packaged in each carton.
5. **FCI will not be held liable for damage caused during shipping.**
6. To ensure immediate processing **mark** the RA number on the outside of the box. Items without an RA number marked on the box or crate may be delayed.
7. Freight **must be "PrePaid"** to FCI receiving door.

* Appropriate dunnage as defined by UPS, will protect package contents from a drop of 3 feet.

***** Decontamination Statement *** This Section Must Be Completed *****

Exposure to hazardous materials is regulated by Federal, State, County and City laws and regulations. These laws provide FCI's employees with the "Right to Know" the hazardous or toxic materials or substances in which they may come in contact while handling returned products. Consequently, FCI's employees must have access to data regarding the hazardous or toxic materials or substances the equipment has been exposed to while in a customer's possession. Prior to returning the instrument for evaluation/repair, FCI requires thorough compliance with these instructions. The signer of the Certificate must be either a knowledgeable Engineer, Safety Manager, Industrial Hygenist or of similar knowledge or training and responsible for the safe handling of the material to which the unit has been exposed. **Returns without a legitimate Certification of Decontamination, and/or MSDS when required, are unacceptable and shall be returned at the customer's expense and risk.** Properly executed Certifications of Decontamination must be provided before a repair authorization (RA) number will be issued.

Certification Of Decontamination

I certify that the returned item(s) has(have) been thoroughly and completely cleaned. If the returned item(s) has(have) been exposed to hazardous or toxic materials or substances, even though it (they) has (have) been thoroughly cleaned and decontaminated, the undersigned attests that the attached Material Data Safety Sheet(s) (MSDS) covers said materials or substances completely. Furthermore, I understand that this Certificate, and providing the MSDS, shall not waive our responsibility to provide a neutralized, decontaminated, and clean product for evaluation/repair at FCI. Cleanliness of a returned item or acceptability of the MSDS shall be at the sole discretion of FCI. **Any item returned which does not comply with this certification shall be returned to your location Freight Collect and at your risk.**

This certification must be signed by knowledgeable personnel responsible for maintaining or managing the safety program at your facility.

Process Flow Media _____

Product was or may have been exposed to the following substances: _____

Print Name _____

Authorized Signature _____ Date _____

Company Title _____

Visit FCI on the Worldwide Web: www.fluidcomponents.com

1755 La Costa Meadows Drive, San Marcos, California 92078-5115 USA † Phone: 760-744-6950 † 800-854-1993 † Fax: 760-736-6250

FCI Document No. 05CS00004D [U]

WARRANTIES

Goods furnished by the Seller are to be within the limits and of the sizes published by the Seller and subject to the Seller's standard tolerances for variations. All items made by the Seller are inspected before shipment, and should any of said items prove defective due to faults in manufacture or performance under Seller approved applications, or fail to meet the written specifications accepted by the Seller, they will be replaced or repaired by Seller at no charge to Buyer provided return or notice of rejection of such material is made within a reasonable period but in no event longer than one (1) year for non-calibration defects and one (1) year for calibration defects from date of shipment to Buyer, and provided further, that an examination by Seller discloses to Seller's reasonable satisfaction that the defect is covered by this warranty and that the Buyer has not returned the equipment in a damaged condition due to Buyer's or Buyer's employees', agents', or representatives' negligence and Buyer has not tampered, modified, redesigned, misapplied, abused, or misused the goods as to cause the goods to fail. In addition, this warranty shall not cover damage caused by Buyer's exposure of the goods to corrosive or abrasive environments. Moreover, Seller shall in no event be responsible for (1) the cost or repair of any work done by Buyer on material furnished hereunder (unless specifically authorized in writing in each instance by Seller), (2) the cost or repair of any modifications added by a Distributor or a third party, (3) any consequential or incidental damages, losses, or expenses in connection with or by reason of the use of or inability to use goods purchased for any purpose, and Seller's liability shall be specifically limited to free replacement, or refund of the purchase price, at Seller's option, provided return or rejection of the goods is made consistent with this paragraph, and the Seller shall in no event be liable for transportation, installation, adjustment, loss of good will or profits, or other expenses which may arise in connection with such returned goods, or (4) the design of products or their suitability for the purpose for which they are intended or used. Should the Buyer receive defective goods as defined by this paragraph, the Buyer shall notify the Seller immediately, stating full particulars in support of his claim, and should the Seller agree to a return of the goods, the Buyer shall follow Seller's packaging and transportation directions explicitly. In no case are the goods to be returned without first obtaining a return authorization from the Seller. Any repair or replacement shall be at Seller's factory, unless otherwise directed, and shall be returned to Seller transportation prepaid by Buyer. If the returned goods shall prove defective under this clause they will be replaced or repaired by Seller at no charge to Buyer provided the return or rejection of such material is made within a reasonable period, but in no event longer than (1) year from the date of shipment of the returned goods or the unexpired terms of the original warranty period whichever is later. If the goods prove to be defective under this paragraph, the Buyer shall remove the goods immediately from the process and prepare the goods for shipment to Seller. Continued use or operation of defective goods is not warranted by Seller and damage occurring due to continued use or operation shall be for Buyer's account. Any description of the goods contained in this offer is for the sole purpose of identifying them, and any such description is not part of the basis of the bargain, and does not constitute a warranty that the goods will conform to that description. The use of any sample or model in connection with this offer is for illustrative purposes only, is not part of the basis of the bargain, and is not to be construed as a warranty that the goods will conform to the sample or model. No affirmation of that fact or promise made by the Seller, whether or not in this offer, will constitute a warranty that the goods will conform to the affirmation or promise. THIS WARRANTY IS EXPRESSLY IN LIEU OF ANY AND ALL OTHER EXPRESS OR IMPLIED WARRANTIES WITH RESPECT TO THE GOODS OR THEIR INSTALLATION, USE, OPERATION, REPLACEMENT OR REPAIR, INCLUDING ANY IMPLIED WARRANTY OF MERCHANTABILITY OR FITNESS OF PURPOSE; AND THE GOODS ARE BEING PURCHASED BY BUYER "AS IS". SELLER WILL NOT BE LIABLE BY VIRTUE OF THIS WARRANTY OR OTHERWISE FOR ANY SPECIAL, INCIDENTAL OR CONSEQUENTIAL LOSS OR DAMAGE RESULTING FROM THE USE OR LOSS OF USE OF THE GOODS.



*Flow & Level Instrumentation
Solutions for Industrial Processes*

**FCI's Complete Customer Commitment. Worldwide
ISO 9001 and AS9100 Certified**

Visit FCI on the Worldwide Web: www.fluidcomponents.com

FCI World Headquarters

1755 La Costa Meadows Drive | San Marcos, California 92078 USA | Phone: 760-744-6950 Toll Free (US): 800-854-1993 Fax: 760-736-6250

FCI Europe

Persephonestraat 3-01 | 5047 TT Tilburg, The Netherlands | Phone: 31-13-5159989 Fax: 31-13-5799036

FCI Measurement and Control Technology (Beijing) Co., LTD | www.fluidcomponents.cn

Room 107, Xianfeng Building II, No.7 Kaituo Road, Shangdi IT Industry Base, Haidian District | Beijing 100085, P. R. China
Phone: 86-10-82782381 Fax: 86-10-58851152

Notice of Proprietary Rights

This document contains confidential technical data, including trade secrets and proprietary information which is the property of Fluid Components International LLC (FCI). Disclosure of this data to you is expressly conditioned upon your assent that its use is limited to use within your company only (and does not include manufacture or processing uses). Any other use is strictly prohibited without the prior written consent of FCI.