

# FCI MT100 Series Multipoint Thermal Mass Flow Meters

Advanced Air and Gas Flow Metering Solutions  
for Large Diameter Pipes, Stacks and Ducts

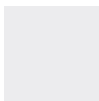
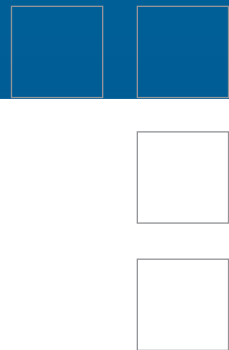
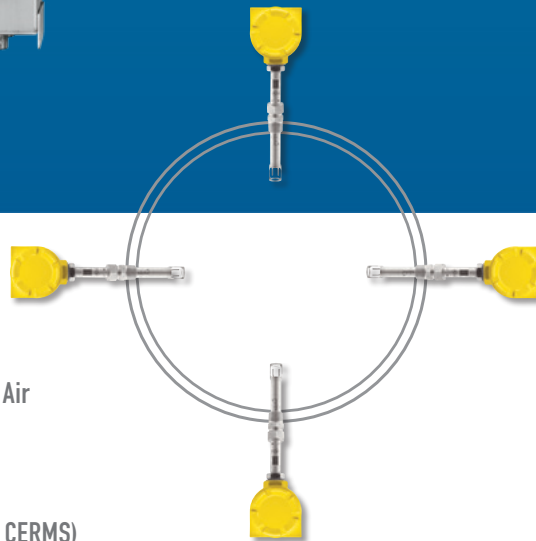
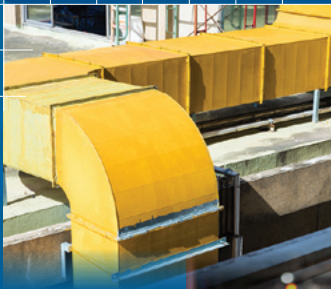

- Combustion Air
- Primary, Secondary, Overfire Air
- Preheated Air
- Boiler Air Feed
- Emissions Monitoring (CEMS, CERMS)
- Industrial and Plant HVAC Control
- Flue Gases
- Stack Gases

FCI MT100 SERIES



## MT100 Series Features

- **Dual function: flow and temperature**
- **Direct mass flow measuring**
- **No moving parts, no orifices to clog, lowest maintenance**
- **Mast-type or multiple single-point flow elements**
- **Digital + graphical color LCD readout with touch-type screen**
- **Dual 4-20 mA + frequency/pulse analog outputs**
- **HART, FOUNDATION™ Fieldbus, PROFIBUS, Modbus Bus Comms**
- **EPA CEMS Compliant**
- **Temperature service to 850 °F [454 °C]**
- **Wide flow range, high turndown**
- **Low flow sensitivity**
- **Up to eight (8) points per system**
- **Built-in data logger**
- **Calibration self-test**

### MT100 Series – Air and Gas Flow Meter Solutions Designed for Large Pipe and Duct Applications

Large diameter pipes and ducts present unique challenges to achieve successful flow meter installation and performance. Lack of straight-run, distorted flow profiles, low flow rates and wide turndowns rates are common performance challenges for many flow metering technologies. Installations can be complicated by difficult access points, single plane platforms, long cable runs, extra mechanical support and exposure to weather extremes. Further, in many applications, the gas being measured can be dirty and/or at high temperatures which can result in measurement degradation, clogging and fouling leading to excessive maintenance procedures or premature failures of many flow meter technologies. FCI has been providing application optimized, low maintenance and cost effective air/gas flow meter solutions for large pipe and ducts for more than three decades.

FCI's MT100 Series combines state-of-the-art, precision electronic technology with application proven flow sensors and plant ruggedized packaging to provide you with a highly accurate, reliable and low maintenance flow meter solution for large diameter

pipes, stacks and rectangular duct installations. The MT100 Series is a multipoint, direct mass flow meter for air and gases, using thermal dispersion mass flow technology. Depending on installation conditions and line size, FCI application engineers will recommend from two (2) to eight (8) flow rate sense points. The sensors are inserted into pipe/duct and multiplexed to produce an averaged output of flow rate within the process line. To best optimize the installation, the sensors may be installed across a mast\* (or bar) or may be single-point sensors\* inserted at multiple points around the process line. Further, because sensors are installed in a single plane, installations in large stacks can be accomplished from a single platform. This achieves significant savings in installation costs and complexity over flow meter technologies such as ultrasonics which require transducers to be installed at a precise offset angle. The MT100 sensors excel in the application because there are no moving parts or orifices to foul or clog and it can be applied in process temperatures up to 850 °F [454 °C]. The MT100 transmitter provides an extensive choice of output options for interface with virtually any DCS, PLC, SCADA, recorder or control system. Its large color LCD touch-screen has digital displays, bar graph, trend graph, diagnostic and more, to provide you best-in-class process

\* The Model MT100M is used when the mast-type flow sensors are required; Model MT100S is used when single-point sensors are required

information. For CEMS applications, MT100 has optional features and functions to meet EPA requirements.

Your investment in an MT100 Series flow meter is completed with FCI's precision calibration. Calibration is performed in FCI's world-class flow calibration laboratory using equipment traceable to NIST (US National Institute of Standards and Technology) and ISO/IEC 17025 international standards for test lab quality systems. Calibrations are matched to your gas and process conditions resulting in best possible installation accuracy and repeatability for your installation.

## MT100 Outputs and Bus Communications for Today and Tomorrow

Comprehensive, scalable and flexible describe the MT100 Series outputs and user interfaces. Analog outputs, bus communications, and computer I/O ports ensure interface and integration into your systems.

The standard outputs bundle includes dual 4-20 mA analog outputs which are user assignable to flow rate and/or temperature, and user scalable to represent the full range or any subset. These 4-20 mA outputs are isolated and have fault indication per NAMUR NE43 guidelines, user selectable for high (>21.0 mA) or low (<3.6 mA). Additionally available is a user selectable 0-1 kHz or 0-10 kHz frequency or pulse output of flow rate.

For digital communications, the standard MT100 includes two digital buses, HART and Modbus. For use with HART programmers and HART-based control systems, the MT100's HART bus is full two-way I/O, version 7 compliant, has been tested and certified by the HART foundation, and is a registered device with the HART organization (FieldComm Group). The HART device driver (DD) file is included and can also be downloaded from either FCI's or FieldComm Group's website. The MT100's Modbus is RS485 ASCII or RTU serial I/O available on a RJ11 connection.



MT100 Series with HART® communications is a certified and registered device with FieldComm Group, registration number L2-06-1000-575. Manufacturer ID (HEX) 00A6.

In addition to the analog outputs and bus communications, the MT100 also features a USB and Ethernet port. The USB port provides simple, direct connection to a laptop or other computer for all user set-up programming, field adjustable device changes and service diagnostics. The MT100 is supplied with "configuration/set-up" software for user's computers — updates and software can be uploaded from FCI's website as needed. The MT100's Ethernet is a service port, standard 10/100 network port designed for and intended for connection with FCI's service department to perform remote service and diagnostics. With authorized secure access, this feature can provide users with significant savings in time and expense by allowing FCI technicians to troubleshoot an MT100 over the internet and get it back on line faster.

## Extended Digital Bus Communications

Optionally available with MT100 are FOUNDATION Fieldbus and PROFIBUS digital communications. These industry standard bus comms are full two way I/O communications to interface directly with process control and measurement systems for seamless integration. The FOUNDATION Fieldbus is H1 and PROFIBUS is -PA. Device driver (DD) and PDM files are always provided and may also be uploaded from FCI's website and/or the respective bus organization's website.



www.profibus.com



www.fieldbus.org

MT100 with FOUNDATION™ Fieldbus communications is a certified and registered device with FieldComm Group™. Registered features include alarms and events, function block linking, trending, multi-bit alert reporting and field diagnostics. Manufacturer ID (HEX) 01FC49.

### MT100 M

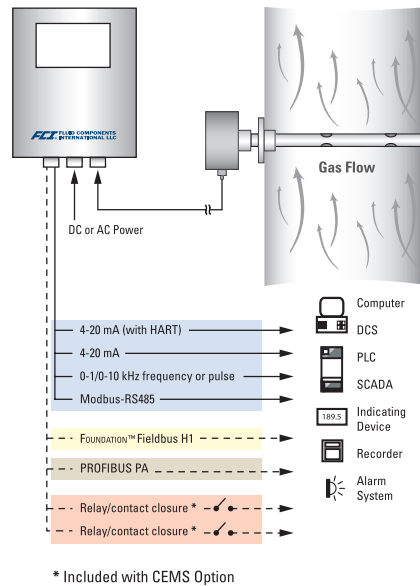

### MT100 S

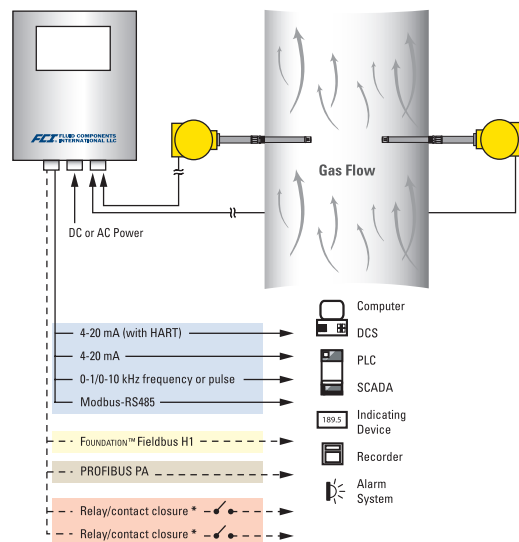

## In-Situ Calibration Validation Self-Test

Standard with all MT100 Series flow meters is a calibration self-test feature. To save time and expense, the self-test is performed in-situ and there is never a need for the MT100 to be removed or retracted from process piping or to suspend the processes operation.

This self-test feature initiates a 3-point calibration and electronic drift self-test for each sensor point in the system. The three points represent a low-range, mid-range and high-range point to provide a thorough check across the span of the flow range. The self-test may be initiated in three ways by the user:

- 1) On demand from the flow meter display's keypad
- 2) On demand from a computer connected to the flow meter's USB port
- 3) Automatically on pre-set day(s) and time(s) as programmed by the user

The results of the self-test provides the operator with an easy to understand PASS/FAIL message for each of the three test points, plus the digital reading of the actual base line values and the actual resulting test values. The results are displayed on the MT100's digital display or the computer connected to the USB port. If the test was initiated automatically, results will be recorded to the MT100's on-board data logger with day and time stamp for user retrieval as desired.

## On-Board Data Logger

MT100 Series electronics include a user selectable and programmable data logging feature. It logs (date and time stamp) flow rate, temperature, and totalized flow in user's engineering units, as well as fault codes. The data is recorded to and stored onboard to a removable MicroSD card. It is supplied with an 8GB capacity card which is capable of storing approximately 80 million readings. (For greater storage capacity, it will accept user supplied 16 GB and 32 GB cards as well.) The recording time is user selectable with a maximum of one reading per 10 seconds. This data is stored in the comma separated value (.csv) format for easy uploading into spreadsheet and chart tools such as Microsoft Excel. The stored data can be retrieved by removing the MicroSD card and extracting the data on it, or by uploading the data with the MT100's USB port.

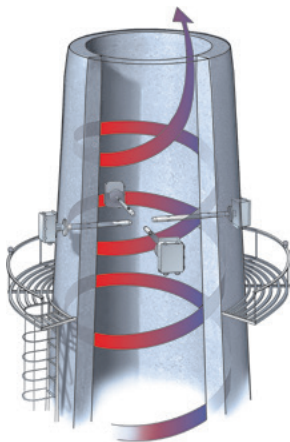

*FCI's MT100 is a highly accurate, reliable and low maintenance flow meter solution for large diameter pipes, stacks and rectangular duct installations.*

## EPA CEMS, CERMS Compliance Option

To comply with local environmental regulations for measuring, monitoring and reporting of flow emissions from stacks, flues or other larger diameter pipe, the MT100 is your solution. The MT100 can be optionally equipped with a CEMS package to meet USA EPA\* CEMS and CERMS applications. The MT100 CEMS option provides automatic and on demand checks for both interference and calibration drift. The system check will check for sensor for potential contamination or blockage and will perform calibration checks at low and high range/span points. The CEMS check can be initiated on demand via the display's "SYS CHK" button and user set to run automatically at any desired time of day. The test results will be displayed with easily understood "pass" or "fail" message and "green" or "red" lamp symbol, respectively. In the event of a fail, the user can interrogate the instrument through the diagnostics menu to see the specific item failure and actual tested values.



In addition, this CEMS option includes two relay outputs to interface with external alarms or warning lamps, or as a discrete, separate signal to DCS or signal test-in-practice and out-of-tolerance conditions.

*\* US EPA 40 CFR Part 60 and Part 75*

## Agency Approvals and Certifications

All MT100 Series have been independently tested and verified to meet and comply with IEC directives for EMC and LVD, and carry the CE marking.

Optionally available, for process installations with hazardous, potentially explosive gases and/or dust, the MT100 can be ordered with FM/FMc, ATEX or IECEx agency approvals for Division II/Zone 2.

FM/FMc: Class I, Division 2, Groups A, B, C, and D  
Class II/III, Division 2, Groups E, F, and G

ATEX: II 3 G Ex nA IIC T6...T1 Gc  
II 3 D Ex tc IIIC T85°C...T450°C Dc

IECE: Ex nA IIC T6...T1 Gc  
Ex tc IIIC T85°C...T450°C Dc

*FCI continually obtains additional agency and special country approvals. Contact FCI for availability of other agency approvals.*



## Best-in-Class Operator's Display / Readout

The MT100 readout is a touch-screen, backlit, color LCD that provides the operator with comprehensive information about the process and status of the flow meter. It provides a digital value of the flow rate, total flow, process temperature in user's selected engineering unit. A 0-100% bar graph of flow rate is continuously displayed. A large strip chart of the flow rate provides the operator with an immediate indication of the process performance over time. Also included is alarm status indication. In the field at the top of the display is a user writable, 20 character field to display information such as process name, location, tag number or gas type.

The status of each flow sensor in the system is also continuously

displayed to the operator. A correctly operating sensor is displayed with a green lamp. In the event a sensor fails, its lamp will immediately change its color to red. When the optional CEMS mode is included, a readout of the most recent CEMS calibration drift test results is continuously displayed with an easy to understand "pass" or "fail" state. When the MT100 is placed in the diagnostics mode, the display will show menu selection and display the results to the operator.

The display also embeds touch-type keys to enter and navigate through menus and measurement or diagnostics modes. To ensure superior protection and longest service life of the display in process and plant installations, the display is behind an extra protective, clear, sealed window. It is always viewable but activating the keys requires opening the enclosure's door.

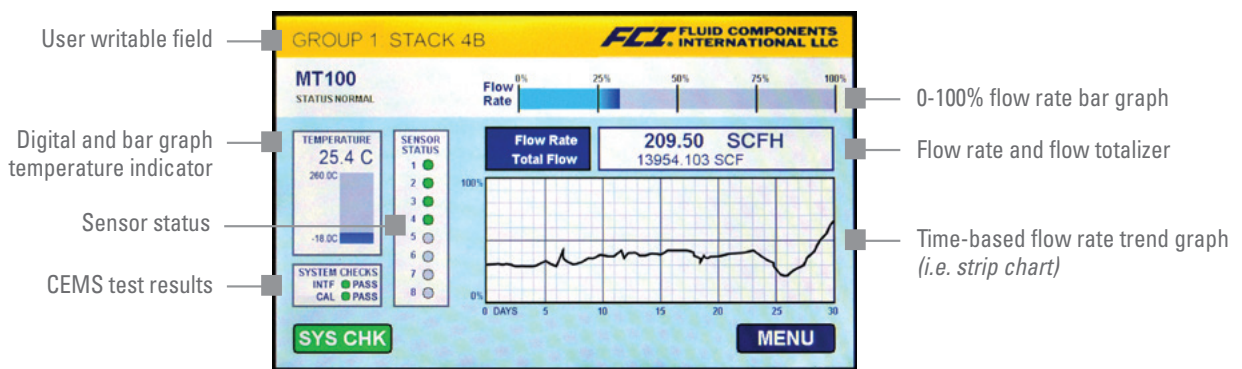

### 1. Combustion Air and Preheated Air

To keep boilers, furnaces, and cogeneration units operating at maximum efficiency, individual combustion and preheater air flow feed lines are metered with the MT Series.

FCI thermal dispersion mass flow meters are well suited for high humidity air flow with water vapor content. Many local climates have high humidity, and air feed to the furnaces have high water vapor content. FCI's constant power thermal dispersion technology, which provides a drying effect, is best suited for this application. The application also has a low process pressure of less than 1 psig [0,056 bar (g)], making it difficult for differential pressure type instruments.

### 2. Stack Emissions

Reliable and accurate measurement of flow from effluent stacks in power, cogeneration, chemical, paper, refinery, and other industrial plants is critical to properly calculate total emissions. The MT Series can be used alone or in conjunction with environmental and/or radiation monitors for this purpose.

### 3. Flue Gas/Scrubber Balancing

Industrial pollution control systems can be operated far more effectively by utilizing the MT Series to meter and balance the flow of flue gas through scrubbers, precipitators and bag houses. Ultrasensitive, the MT Series offers unsurpassed accuracy across broad flow ranges. The unit's no-moving-parts design is non-fouling and causes virtually no pressure drop in large lines.

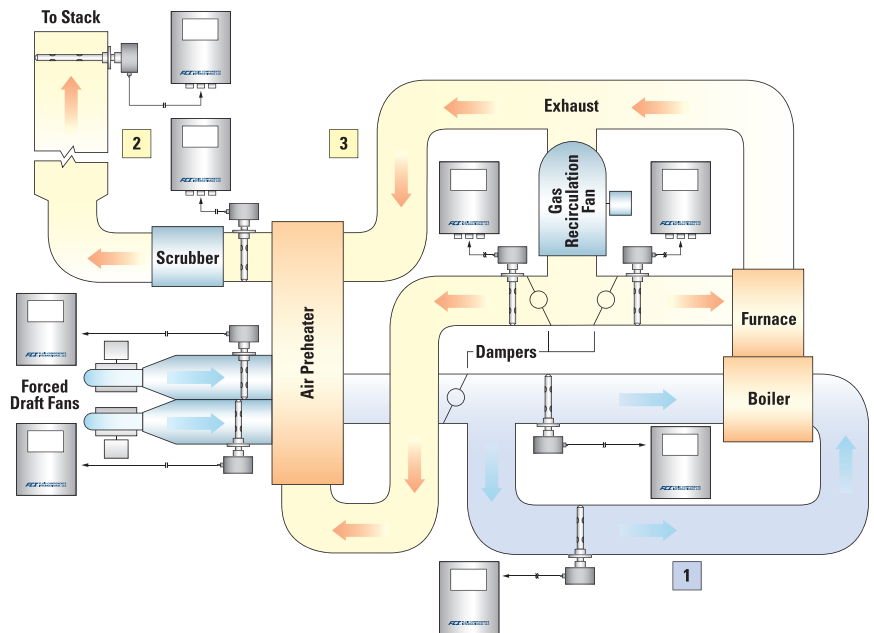

- Unaffected by entrained fly ash. No moving parts or small ports to clog up. Eliminates the need for sensor purging.
- Flow measurement from 0.3 FPS [0,1 m/sec] compared to more than 10 FPS [3 m/sec] for any differential pressure type instrument.
- Single platform installation versus second platform for offset angle ultrasonic meters.
- Flow transmitter electronics are remotely mounted at ground level of stack for safe access.

# MT100 Features

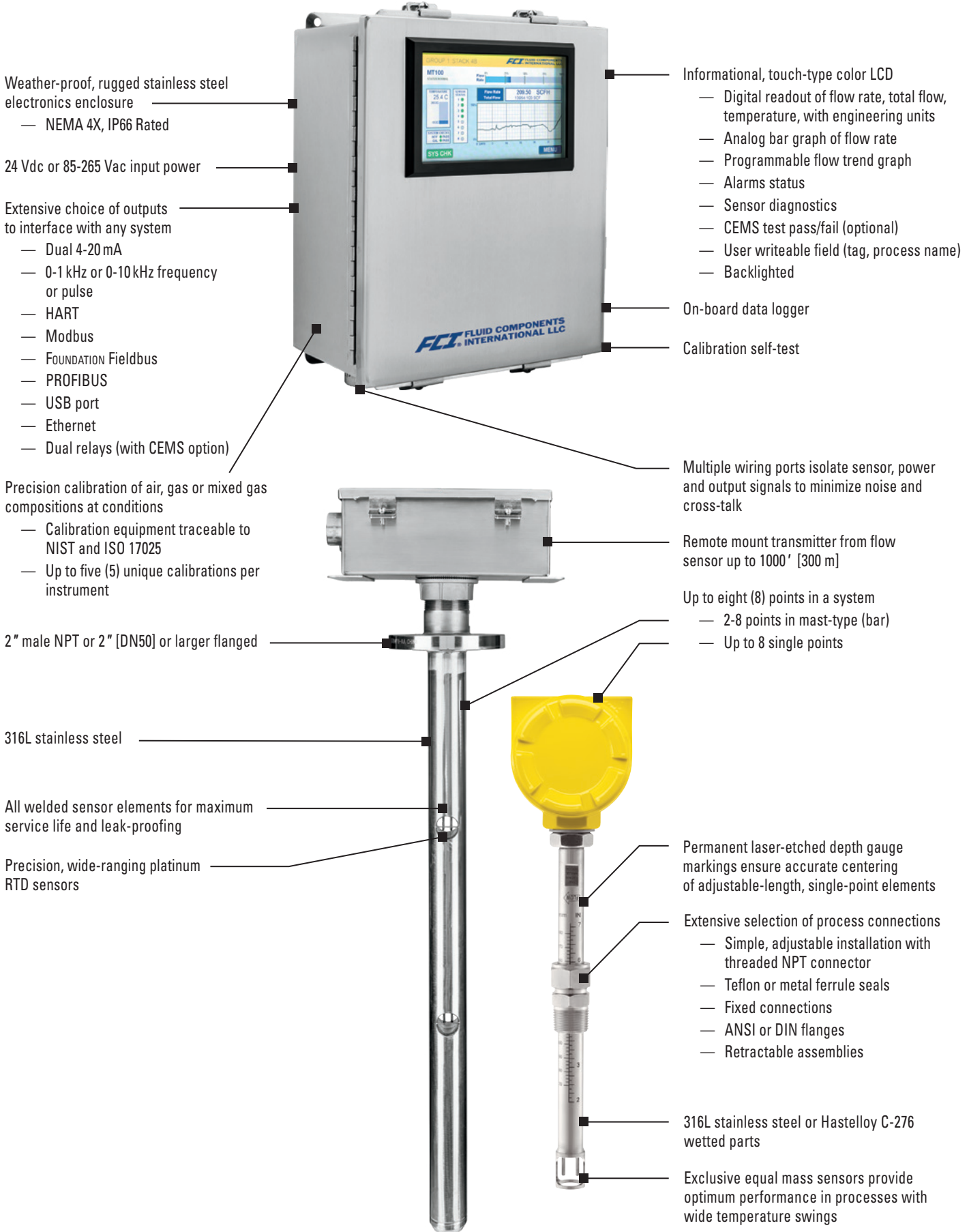

Weather-proof, rugged stainless steel electronics enclosure  
 — NEMA 4X, IP66 Rated

24 Vdc or 85-265 Vac input power

Extensive choice of outputs to interface with any system  
 — Dual 4-20 mA  
 — 0-1 kHz or 0-10 kHz frequency or pulse  
 — HART  
 — Modbus  
 — FOUNDATION Fieldbus  
 — PROFIBUS  
 — USB port  
 — Ethernet  
 — Dual relays (with CEMS option)

Precision calibration of air, gas or mixed gas compositions at conditions  
 — Calibration equipment traceable to NIST and ISO 17025  
 — Up to five (5) unique calibrations per instrument

2" male NPT or 2" [DN50] or larger flanged

316L stainless steel

All welded sensor elements for maximum service life and leak-proofing

Precision, wide-ranging platinum RTD sensors

Informational, touch-type color LCD  
 — Digital readout of flow rate, total flow, temperature, with engineering units  
 — Analog bar graph of flow rate  
 — Programmable flow trend graph  
 — Alarms status  
 — Sensor diagnostics  
 — CEMS test pass/fail (optional)  
 — User writeable field (tag, process name)  
 — Backlighted

On-board data logger

Calibration self-test

Multiple wiring ports isolate sensor, power and output signals to minimize noise and cross-talk

Remote mount transmitter from flow sensor up to 1000' [300 m]

Up to eight (8) points in a system  
 — 2-8 points in mast-type (bar)  
 — Up to 8 single points

Permanent laser-etched depth gauge markings ensure accurate centering of adjustable-length, single-point elements

Extensive selection of process connections  
 — Simple, adjustable installation with threaded NPT connector  
 — Teflon or metal ferrule seals  
 — Fixed connections  
 — ANSI or DIN flanges  
 — Retractable assemblies

316L stainless steel or Hastelloy C-276 wetted parts

Exclusive equal mass sensors provide optimum performance in processes with wide temperature swings

# MT100 Series Specifications

## Instrument

### Measuring Capability

Multipoint, averaging flow rate system for air and gases in large diameter pipes and rectangular ducts; provides flow rate, totalized flow, temperature

### Basic Style

**MT100M** Insertion with two or more sense points on one or more mast-type flow element probes; minimum of two (2) points per mast; maximum of eight (8) points on single mast

**MT100S** Insertion with up to 8 single-point flow elements

### Flow Measurement Range

**MT100M** 0.25 SFPS to 150 SFPS [0,07 NMPS to 46 NMPS]

**MT100S** 0.25 SFPS to 1000 SFPS [0,07 NMPS to 305 NMPS]

*Air at standard conditions, 70 °F and 14.7 psia [ 21,1 °C and 1,01325 bar(a)]*

### Temperature Measurement Range

-50 °F to 500 °F [-45 °C to 260 °C] or

-50 °F to 850 °F [-45 °C to 454 °C]

### Media/Fluid

All air, gas and gas combinations that are compatible with the flow element's wetted materials

### Accuracy

**Flow** ± 1.75% of reading, ± 0.5% of full scale

**Temperature** ± 2 °F [± 1,1 °C]

### Repeatability

**Flow** ± 0.5% of reading

**Temperature** ± 1 °F [± 1 °C]

### Temperature Coefficient (Flow)

With optional temperature compensation, valid from 10% to 100% of full scale calibration

Maximum ± 0.015% of reading/°F up to 850 °C [± 0.03% if reading/°C up to 454 °C]

### Turndown Ratio

Normally factory set and field adjustable from 2:1 to 100:1 within calibrated range; higher ratios possible with factory evaluation of application

### Temperature Compensation

**Standard** ± 30 °F [± 16 °C]

**Extended (optional)** ± 100 °F [± 55 °C]

### Calibration

Performed using equipment traceable to NIST (US National Institute of Standards and Technology) and ISO/IEC 17025 international standards for test lab quality systems

### Agency Approvals

CE marking, CRN (*pending, MT100S only*)

### Agency Approvals *Optional*

FM/FMc: Class I, Division 2, Groups A, B, C, and D

Class II/III, Division 2, Groups E, F, and G

ATEX: II 3 G Ex nA IIC T6...T1 Gc

II 3 D Ex tc IIIC T85°C...T450°C Dc

IECE: Ex nA IIC T6...T1 Gc

Ex tc IIIC T85°C...T450°C Dc

### CEMS Compliance *Optional*

US EPA CEMS: 40 CFR 60 and 40 CFR 75

USA EPA GHG: 40 CFR 98.34(c)(1)

## Flow Element

### Material of Construction

**Mast-type** All-welded, 316L stainless steel

**Single-point** All-welded, 316L stainless steel;

Hastelloy C-276 *Optional*

*Choice of flow sensor design:*

– FP fast response with protective shroud

– FPC same as –FP plus flow conditioner/isolator tab

– S unshrouded for dirty or moist applications

### Operating Temperature (Process)

**Mast-type** -50 °F to 500 °F [-45 °C to 260 °C]

-50 °F to 850 °F [-45 °C to 454 °C]

**Single-point** -40 °F to 500 °F [-40 °C to 260 °C]

-40 °F to 850 °F [-40 °C to 454 °C]

### Operating Pressure (Process)

**Mast-type** 100 psig [6,9 bar(g)]

Design pressure to 500 psig [34 bar(g)]

### Single-point

Metal ferrule 1000 psig [70 bar(g)]

Teflon ferrule 150 psig [10 bar(g)] @200 °F/93 °C maximum

Fixed connection (NPT) 1000 psig [70 bar(g)]

Fixed connection (flanged) per flange rating

### Process Connections

**Mast-type:** 2" male NPT; 2" [DN50] or larger flanges

### Single-point

**Compression fittings:** 3/4" or 1" male NPT, stainless steel with adjustable Teflon ferrule or metal ferrule; or flanged tapped and threaded for 3/4" fitting. ANSI or DIN flanges.

*Compression fitting not available with 850 °F/454 °C temperature service versions*

**Retractable packing glands:** Low pressure 50 psig [3,5 bar(g)] or medium pressure 500 psig [34 bar(g)] with graphite or Teflon packing material; 1 1/4" male NPT or ANSI or DIN flange

*Teflon packing material required when process media is ozone, chlorine or bromine*

**Fixed fittings:** 1" male NPT, ANSI flange or DIN flange

*MT100 Series specifications continued on next page*

# MT100 Specifications Cont'd

## Transmitter/Electronics

### ■ Operating Temperature

-40 °F to 150 °F [-40 °C to 65 °C]  
Display/Readout -4 °F [-20 °C]

### ■ Input Power

**DC** 24 Vdc (19.2V to 28.8Vdc)  
4 points, up to 17 watt maximum; up to 8 points, 26 watt maximum  
**AC** 85 V to 265 Vac  
4 points, up to 29 watt maximum; up to 8 points, 43 watt maximum

### ■ Outputs

**Standard:** Two 4-20 mA analog outputs<sup>1</sup> with NAMUR NE43 guidelines; output #1 with HART<sup>2,3</sup>; one 0-1 kHz frequency/pulse; Modbus 485<sup>3</sup>; USB port; ethernet service port

**Optional:** FOUNDATION Fieldbus H1<sup>3</sup>, PROFIBUS-PA<sup>3</sup>

<sup>1</sup> 16 bit resolution

<sup>2</sup> HART is version 7 with instrument and DD files certified by and registered with HART organization

<sup>3</sup> Only one digital bus comm can be operated at a time; e.g. HART and Modbus cannot be in operation simultaneously

### ■ CEMS Compliance *Optional*

Complies with 40 CFR Part 60 and 40 CFR Part 75; provides 24 hour interval automated calibration drift test of low and high span points, and interference sensor check; test can also be performed on demand via button on LCD readout; test results provide data value with pass/fail indication; two relays are also provided for auxiliary connection to alarm panel, PLC or other external device in the event CEMS test fails

### ■ Readout/Display/Keypad *Optional*

Large 7" diagonal color LCD with touch-screen: digital readouts, bar graphs, analog chart, engineering units, alarms and sensor status

- Digital display of flow rate, total flow and temperature; user selectable for engineering units in both imperial or metric units
- Analog bar graph of flow rate
- Analog time graph/plot of flow rate history; user settable time base in hours, days or weeks
- Alarm status with indication of which alarm and value exceeded
- CEMS test pass/fail status (if equipped with CEMS option)
- User writable field of up to 20 characters; example: tag number, location, station, gas type
- Individual sensor diagnostics status lamp  
Green = good; Red = service required
- Touch-type screen for user programmable features and set-up  
*Password protected to prevent unauthorized changes*

### ■ Data Logger

Log to on-board 8 GB microSD card; user programmable for measurements to be logged and time intervals (to maximum of 10 readings/second); SD card is removable and replaceable as needed; data is logged in comma separated value (.csv) format

### ■ Enclosures

#### Main Transmitter/Electronics

Polished stainless steel, 12" H x 10" W x 6" D [305 mm H x 254 mm W x 152 mm D] box with hinged front door; NEMA 4X/IP66 rated; four (4) 1" NPT or M25 conduit ports welded to bottom of enclosure

#### Local Enclosure *Attached to flow element*

**Mast-type (MT100M):** Polished stainless steel, 10" H x 8" W x 4" D [254 mm H x 203 mm W x 102 mm D] box with hinged front door; NEMA 4X/IP66 rated; two (2) 1" NPT or M25 conduit ports welded to bottom of enclosure

#### Single-point (MT100S)

*With compression fittings, 1" flange, or DN25 flange process connections*

**Standard:** NEMA 4X/IP67 polyester powder coated aluminum; 2 conduit ports threaded as 1/2" NPT or M20x1.5

**Optional:** Same as above, in stainless steel

#### Single-point (MT100S)

*With flanges larger than 1"/DN25, packing gland, or fixed process connections*

**Standard:** NEMA 4X/IP67 polyester powder coated aluminum; 1 conduit port threaded as 1" NPT or M20x1.5

**Optional:** Same as above, in stainless steel

## Other Options and Accessories

### ■ Element Coatings and Materials

For service in highly corrosive gases or erosive particulates, FCI can provide special coatings and wetted materials to protect, preserve and extend the service life of the flow elements; coating examples include chromium carbide and nickel

### ■ Ball Valves and Cable Glands

### ■ Certifications, Testing and Documentations

Certificate of Conformance, Certificate of Origin, Certified Material Test Report, welding and welder pedigree, customer witnessed factory acceptance, Positive Material Identification, hydrostat test, dye penetrant test, radiography, and more

### ■ Start-up Assistance and Field Service

Site visit by factory technicians for start-up, installation verification and commissioning; field service for service, in-situ flow profile traversing with calibrated measuring equipment by qualified technician, etc.

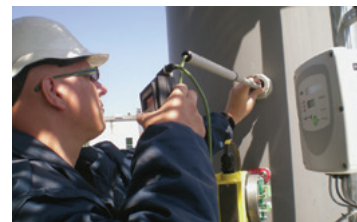



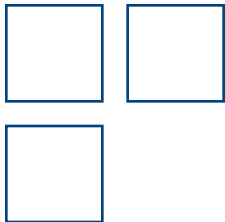

# Model MT100 Multipoint Thermal Mass Flow Meter

## MT100 Series Transmitter Enclosure

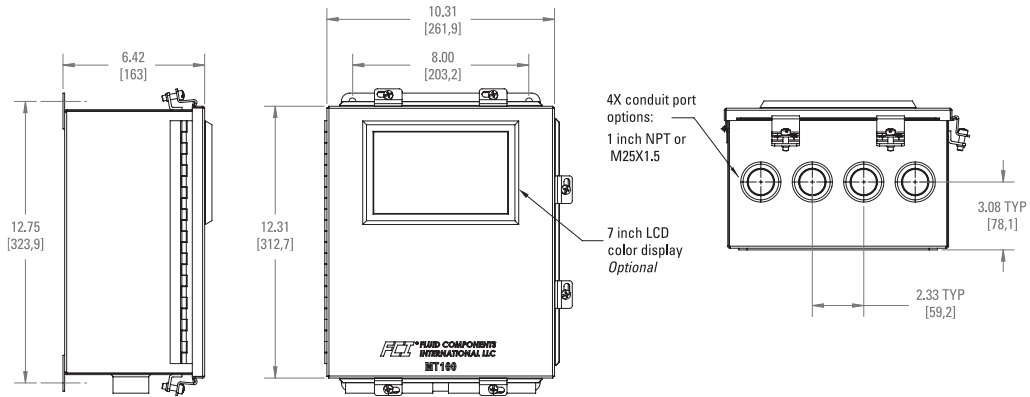

## MT100 M Flow Element Assembly

### 2 Inch NPT Process Connection

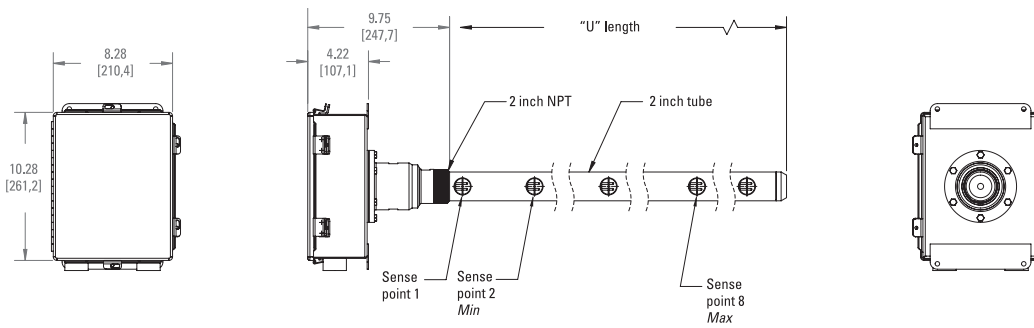

### Flange Process Connection

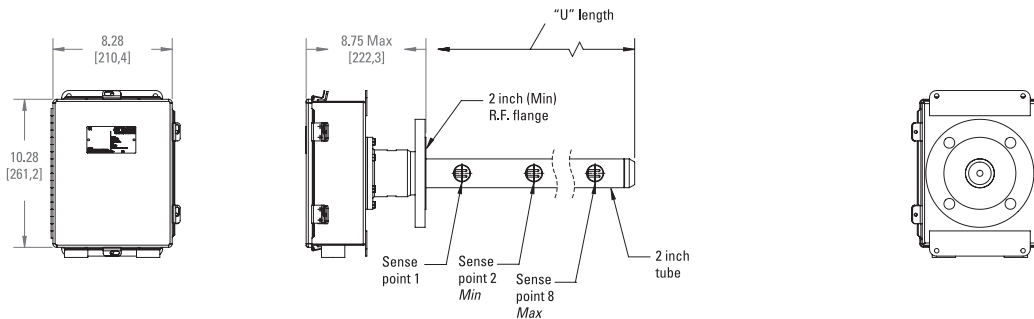

### Duct Flange Process Connection

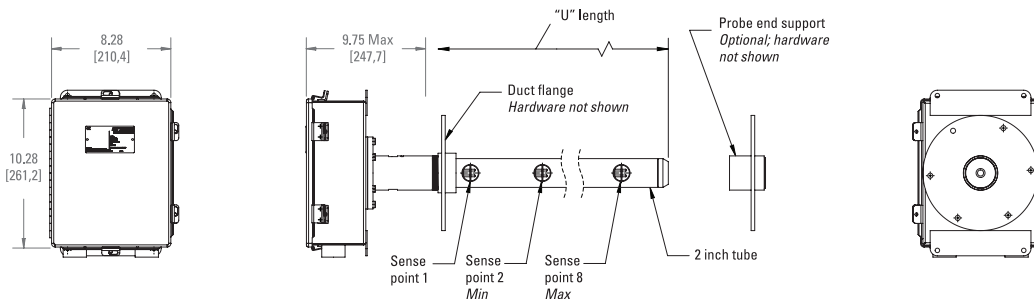

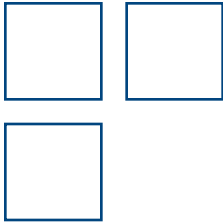

# Model MT100 Multipoint Thermal Mass Flow Meter

## MT100 S Flow Element Assembly

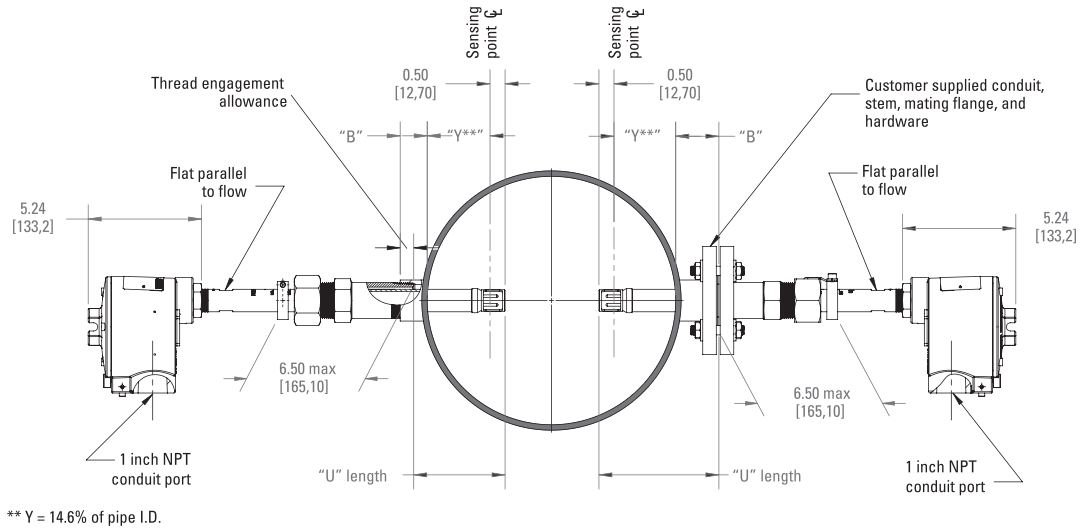

## Compression Fitting Process Connection *Flange Optional*

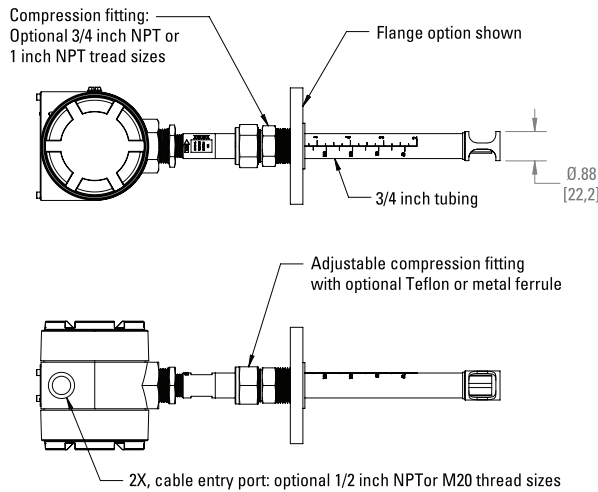

## Low Pressure Retractable Packing Gland Process Connection *Flange Optional*

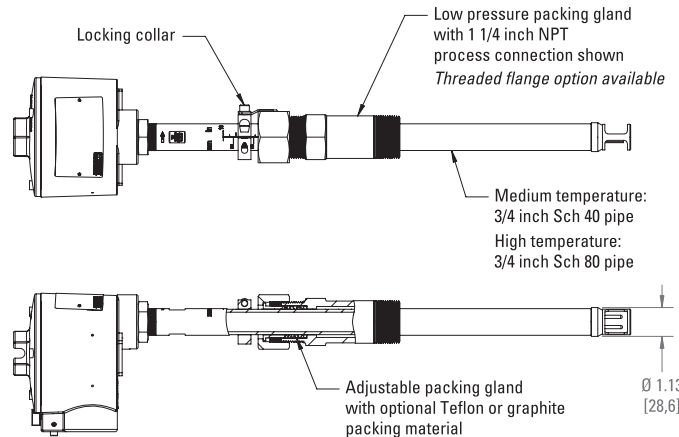

# Model MT100 Multipoint Thermal Mass Flow Meter

## Medium Pressure Retractable Packing Gland Process Connection *Flange Optional*

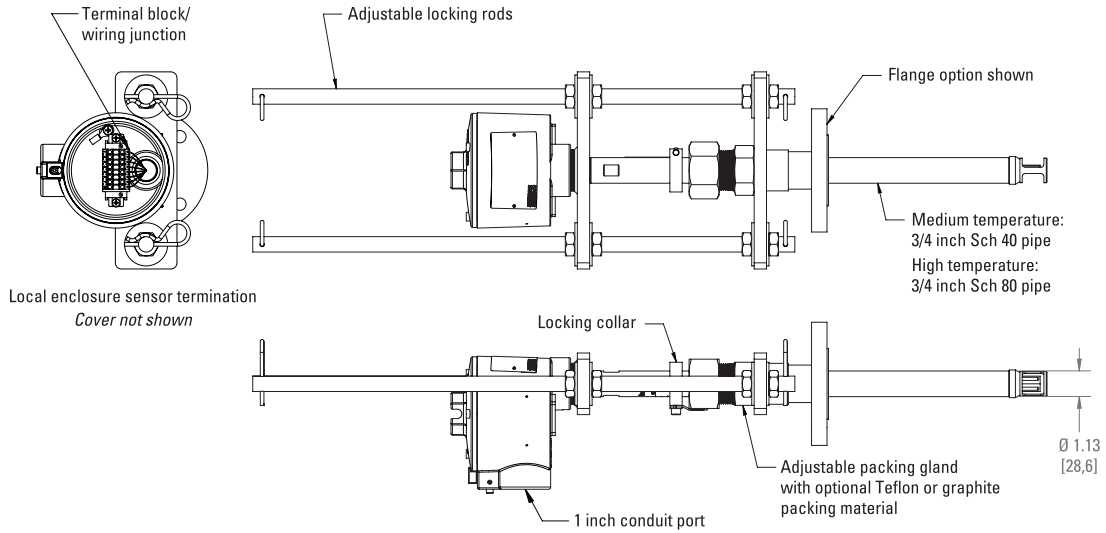

## Fixed 1 Inch NPT Process Connection

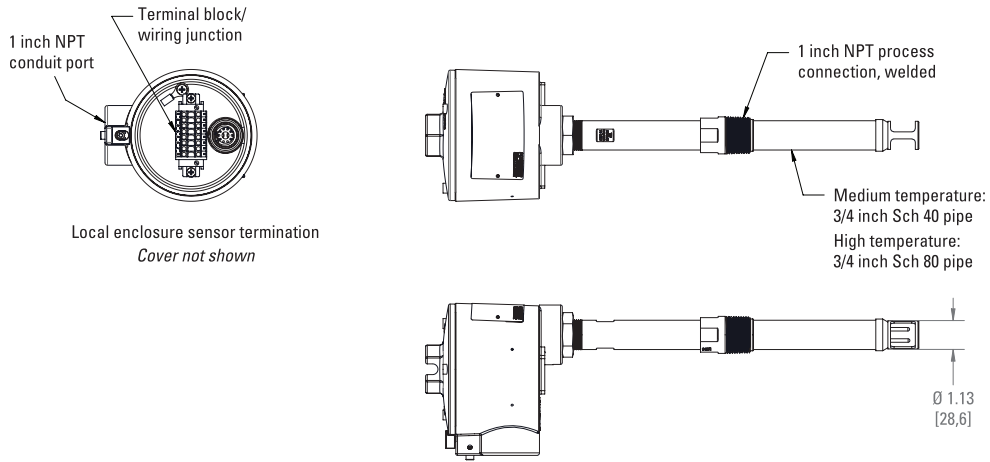

## Fixed Flange Process Connection

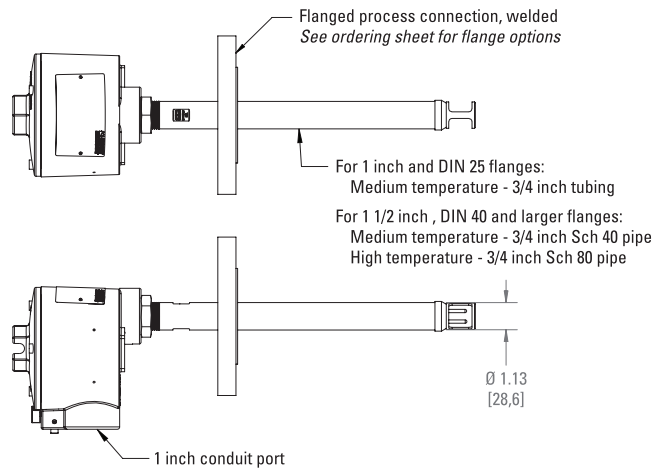



## FCI's World Class Calibration Ensures Installed Accuracy

All FCI products are tested and calibrated to rigorous standards to ensure you get the instrument that does the job you specified. To design and produce the highest quality flow instrumentation, FCI operates a world-class flow calibration laboratory with calibrations performed on more than 19 different flow stands, using equipment traceable to NIST (US National Institute of Standards and Technology), and ISO/IEC 17025 (International Standards for test lab quality systems).



*More than 19 precision flow stands to match NIST traceable fluids, process conditions, flow rates and line sizes specified in your application.*

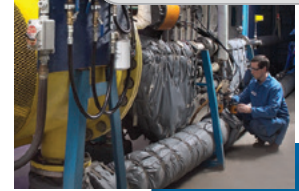

**Request a Quote**



## **FCI** FLUID COMPONENTS INTERNATIONAL LLC

Locally Represented By:

Visit FCI online at [www.FluidComponents.com](http://www.FluidComponents.com) | FCI is ISO 9001 and AS 9100 Certified

### FCI World Headquarters

1755 La Costa Meadows Drive | San Marcos, California 92078 USA  
**Phone:** 760-744-6950 **Toll Free (US):** 800-854-1993

### FCI Europe

Persephonestraat 3-01 | 5047 TT Tilburg, The Netherlands | **Phone:** 31-13-5159989

### FCI Measurement and Control Technology (Beijing) Co., LTD

Room 107, Xianfeng Building II, No.7 Kaituo Road, Shangdi IT Industry Base, Haidian District | Beijing 100085, P. R. China  
**Phone:** 86-10-82782381

