

REVISIONS			
REV	DESCRIPTION	DATE	APPROVED

APPROVALS	 FLUID COMPONENTS INTL a limited liability company San Marcos, CA 92069			
AUTHOR	TITLE Instruction Sheet for the GF03 HART Option			
CHECK				
ENGRG				
MFG				
QA				
	SIZE A	CAGE CODE 64818	DOC NO. 06EN003357	REV -
	RELEASE DATE:	SHEET 1 of 1		

GF03 HART OPTION INSTRUCTION SHEET

Document
06EN003357 Rev. -

Step 1. Installation

This instruction sheet is used to augment other instrument manuals when the Hart option is used. Use the following steps to install the Hart Option for the GF03:

1. All the FCI transmitters that incorporate the HART protocol are set at the factory to polling address "0". Users should reset the polling address to match the needs of their network.
2. At polling address "0", the GF03 outputs a current of 4 - 20mA; at any other polling address, the GF03 outputs a fixed 4mA current; in compliance with the HART standard. A digital signal is provided with all polling addresses.
3. If the GF03 is going to be used as a HART network transmitter, the polling address needs to be changed to other than "0". The power supply feeding the network must provide sufficient current to support the instruments in the network.

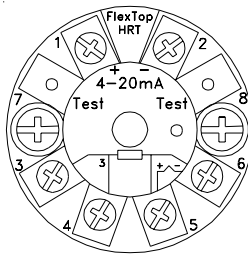

Hart Module

Step 2. Wiring the Hart Instrument

INPUT POWER - Follow the GF03 manual to connect power.

OUTPUT SIGNAL - The GF03 analog outputs are factory connected to the hart modules. The diagram below shows the recommended method of connecting the HART module to the customer's system.

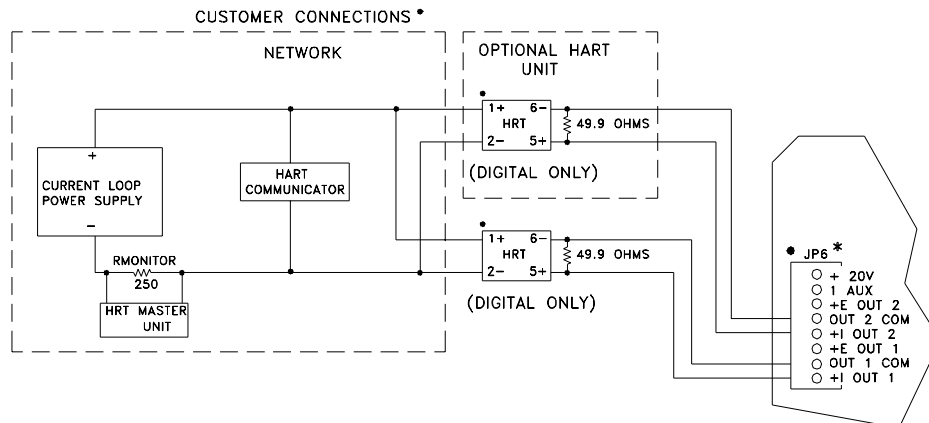

Step 3. Programming the Hart Instrument

GF03 HART MENU TREE

MAIN MENU

- 1 DEVICE SETUP
- 2 VOLT (Displays actual process value, i.e. flow)
- 3 LRV (Displays configured lower range value)
- 4 URV (Displays configured upper range value)
- 5 I OUT (Displays actual output current in mA)
- 6 % RANGE (Displays output current in percent of output span)
- 7 DATALOGGER

1 DEVICE SETUP MENU

- 1 INPUT SETUP
- 2 OUTPUT SETUP
- 3 DEVICE INFO.
- 4 DIAG/SERVICE

7 DATALOGGER MENU

- 1 MAX. VALUE (Displays highest process value since reset)
- 2 MIN. VALUE (Displays lowest process value since reset)
- 3 RESET MIN/MAX (Reset the memory holding min/max data)

1 INPUT SETUP

- 1 SIGNAL CONDITION
- 2 SENSOR TYPE (Enter Sensor type i.e. RTD, T/C, mV, Ohm, Pot)
- 3 LRV (Enter lower range value)
- 4 URV (Enter upper range value)
- 5 DAMP (Enter damping value)

1 Signal Condition

- 1 SENSOR (mV Hi)
- 2 USL (Upper sense level i.e. 1000 mV)
- 3 LSL (Lower sense level i.e. 0 mV)
- 4 MIN SPAN (20 mV)

2 OUTPUT SETUP*

- 1 UNDER LIM (Enter the output current for measurements LOWER than configured range, i.e. if temp. falls below 0°C)
- 2 OVER LIM (Enter the output current for measurements HIGHER than configured range, i.e. if temp. goes above 100°C)
- 3 SENS ERR (Enter the output current in case sensor fails).

*This is a sub menu, where the out-of-range and sensor-burn-out can be entered.

3 DEVICE INFO

- 1 DISTRIBUTOR (Displays name Kamstrup)
- 2 MODEL (Displays name FlexTop HRT)
- 3 DEV ID (Displays device serial number)
- 4 TAG (Enter tag number (identify FlexTop HRT))
- 5 DATE (Enter date of choice, i.e. date of event)
- 6 WRITE PROT. (Displays status of write protection, NONE)
- 7 DESCRIPTOR (Enter description, i.e a location code)
- 8 MESSAGE (Enter a message, i.e. a warning)
- 9 FINAL ASMBLY NUM (Enter 8 digits, i.e. ref # identifying sensor and transmitter during a calibration session)
- 10 REVISION #'s (Displays the rev. #'s of the command set (5), the FlexTop HRT(2) and the DD software (3))
- 11 HART OUTPUT

11 HART Output

- 1 POLL ADR (Enter the polling adr. for the FlexTop HRT. Observe that poll adr = 0 automatically sets the FlexTop HRT in analog mode, resulting in a mixed-signal setup. If intent is to connect several FlexTop's in Multi-drop mode, poll addresses 1 to 15 must be used.
- 2 NUM PREAMS (Displays number of preamble characters sent by master to ensure sync with the slave device.

4 DIAG/SERVICE**

- 1 LOOP TEST (Enter/Change loop current to a fixed value)
- 2 D/A TRIM (Connect a reference meter (5 digit) and compensate for the inaccuracy in the output D/A converter)
- 3 SENSOR TRIM

1 Loop Test

- 1 4 mA FIXED OUTPUT
- 2 20 mA FIXED OUTPUT
- 3 OTHER (Inter value of fixed current output)
- 4 END (Leave the menu)

3 Sensor Trim

- 1 FACTORY TRIM (Offset and gain values are reset to factory settings)
- 2 ONE POINT TRIM (Enter reference temp. value for a non-calibrated sensor. Displays measured temperature. In case the ref temperatures are different, enter this value.
- 3 TWO POINT TRIM (Enter 2 reference temperature values. Displays actual measured temp. In case the reference temps are different, enter the values. The gain is #1, the function curve will change the slope and not start in the zero point)
- 4 VOLT. (Not used by FCI)
- 5 S. OFF. (This is the difference between the measured and the reference value. Enter this value)
- 6 S. GAIN (Enter this value. This adjustment corresponds to the 2-point trim. However the function curve will start in the zero point.

**WARNING: To enter this menu, remove the loop from automatic control. All trim adjustments can be carried out from the configurator only - not from the FlexProgrammer.

Visit FCI on the Worldwide Web: www.fluidcomponents.com

1755 La Costa Meadows Drive, San Marcos, California 92069 USA ~ 760-744-6950 ~ 800-854-1993 ~ Fax 760-736-6250

European Office: Persephonestraat 3-01 5047 TTTilburg - The Netherlands ~ Phone 31-13-5159989 ~ Fax 31-13-5799036

© Copyright 2004 Fluid Components International LLC All Rights Reserved