

# Configuration Software Manual

**ST80/ST80L**  
Thermal Mass Flow Meter

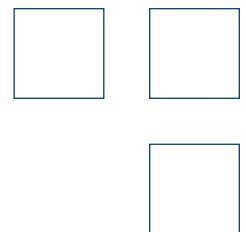

**Notice of Proprietary Rights**

This document contains confidential technical data, including trade secrets and proprietary information which is the property of Fluid Components International LLC (FCI). Disclosure of this data to you is expressly conditioned upon your assent that its use is limited to use within your company only (and does not include manufacture or processing uses). Any other use is strictly prohibited without the prior written consent of FCI.

© Copyright 2018 by Fluid Components International LLC. All rights reserved. FCI is a registered trademark of Fluid Components International LLC. Information subject to change without notice.

## Table of Contents

Introduction.....	1
Installation.....	1
Running the PC Configuration Application.....	1
Configuration Software Basics.....	3
Password Protection.....	3
Basic Setup Tab Screens.....	4
Advanced Setup Tab Screens.....	7
Download Calibration.....	8
Configuration Tab Screens.....	10
Diagnostics Tab Screens.....	12
Factory Tab Screens.....	14
FE1 Process Data.....	18
Parameter Reports.....	19
Compare to Download File.....	20
Customer Service/Technical Support.....	21

## List of Figures

Figure 1 – USB Connector on ST80/ST80L Main Board (Blind Lid Removed).....	1
Figure 2 – Welcome Screen.....	2
Figure 3 – Example Process Data Screen.....	2
Figure 4 – Basic Application Screen Elements.....	3
Figure 5 – Example Groups Tab (Basic Setup).....	4
Figure 6 – Example Units Tab (Basic Setup).....	5
Figure 7 – Example Pipe Size Tab (Basic Setup).....	5
Figure 8 – Example Alarms Tab (Basic Setup).....	5
Figure 9 – Example Totalizer Tab (Basic Setup).....	6
Figure 10 – Example Display Settings Tab (Basic Setup).....	6
Figure 11 – Example User Parameters Tab (Advanced Setup).....	7
Figure 12 – Example Data and Time Tab (Advanced Setup).....	8
Figure 13 – Example Download Calibration Tab (Advanced Setup).....	8
Figure 14 – Example Reboot Device Tab (Advanced Setup).....	8
Figure 15 – Example Flow Filtering Tab (Advanced Setup).....	9
Figure 16 – Example Output Tab (Configuration).....	9
Figure 17 – Example 4-20 mA User Tab (Configuration).....	10
Figure 18 – Example Modbus Tab (Configuration).....	11
Figure 19 – Example AST Power Mode Tab (Configuration).....	11
Figure 20 – Example Status Tab (Diagnostics).....	12
Figure 21 – Example Fault Log Tab and Example Fault Log List (Diagnostics).....	13
Figure 22 – Example idR Scheduled Tests Tab and Example idR On-Demand Test Results Display (Diagnostics).....	13
Figure 23 – Example idR Test Logs Tab and Example idR Test Log List (Diagnostics).....	13
Figure 24 – Example Heater Values Tab (Diagnostics).....	14
Figure 25 – Example Factory Parameters Tab (Factory).....	15
Figure 26 – Example Identification Tab (Factory).....	15
Figure 27 – Example 4-20mA Factory Tab (Factory).....	15
Figure 28 – Example Options Tab (Factory).....	16
Figure 29 – Example HART Tab (Factory).....	16
Figure 30 – Example Memory Tab (Factory).....	16
Figure 31 – Example Reset idRs Tab (Factory).....	17
Figure 32 – Example SIL Adj Tab (Factory).....	17
Figure 33 – Example FE Faults Tab (Factory).....	17
Figure 34 – Example Core Faults Tab (Factory).....	18
Figure 35 – Example Process Data Screen (FE1).....	18
Figure 36 – Example Parameter Report, Group 1.....	19
Figure 37 – Example Parameter Report, Group 5.....	19
Figure 38 – Example Parameter Report With Download File Comparison Results.....	20

**List of Tables**

Table 1 – Basic Setup Tabs ..... 4  
Table 2 – Advanced Setup Tabs ..... 7  
Table 3 – Configuration Tabs ..... 10  
Table 4 – Diagnostics Tabs ..... 12  
Table 5 – Factory Tabs ..... 14

## Introduction

The ST80/ST80L Configuration software is a Windows PC application that lets you easily set up and configure the ST80/ST80L thermal mass flow meter. Use this tool for all instrument commissioning activity. Note that the software application serves both ST and MT series product lines. This manual, however, covers operation with ST80/ST80L only (software version 3.2.0.x).

## Installation

Find the Software Configurator MSI install file in the Software folder on the product documentation CD or downloaded over the web. The file can be identified by name – *ST MT Configurator v3200.msi*. Copy this file to a location on your PC designated for ST80/ST80L documentation.

Run the MSI installer file (make sure you have administrative rights to install) and follow the on-screen instructions to complete the installation (uninstall any previous version of the software first). The installation process places an application shortcut icon of a stylized meter face on the Windows desktop:  The installer also creates a folder in the Start Menu named *Fluid Components Intl*, which contains another program shortcut.

## Running the PC Configuration Application

Connect the host PC via USB:

- Connect the instrument to the PC USB port using the USB cable provided. Remove the instrument's blind lid and plug the cable end with the square-shaped plug into the instrument's Type B USB connector J21. Locate this connector at the bottom edge of the main board as shown in the figure below. Plug the other end of this cable (flat plug) into the PC's USB port

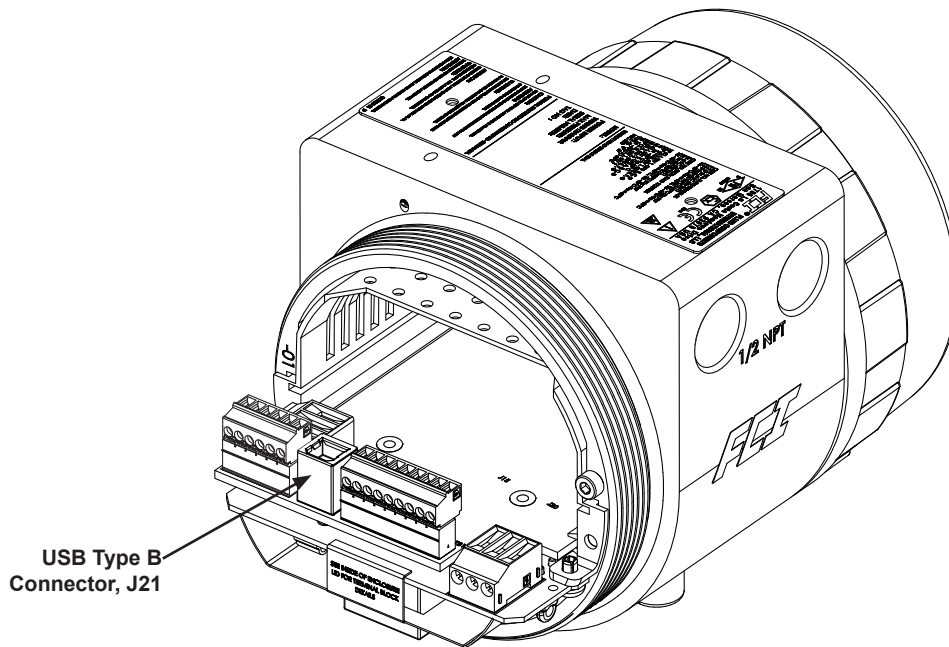
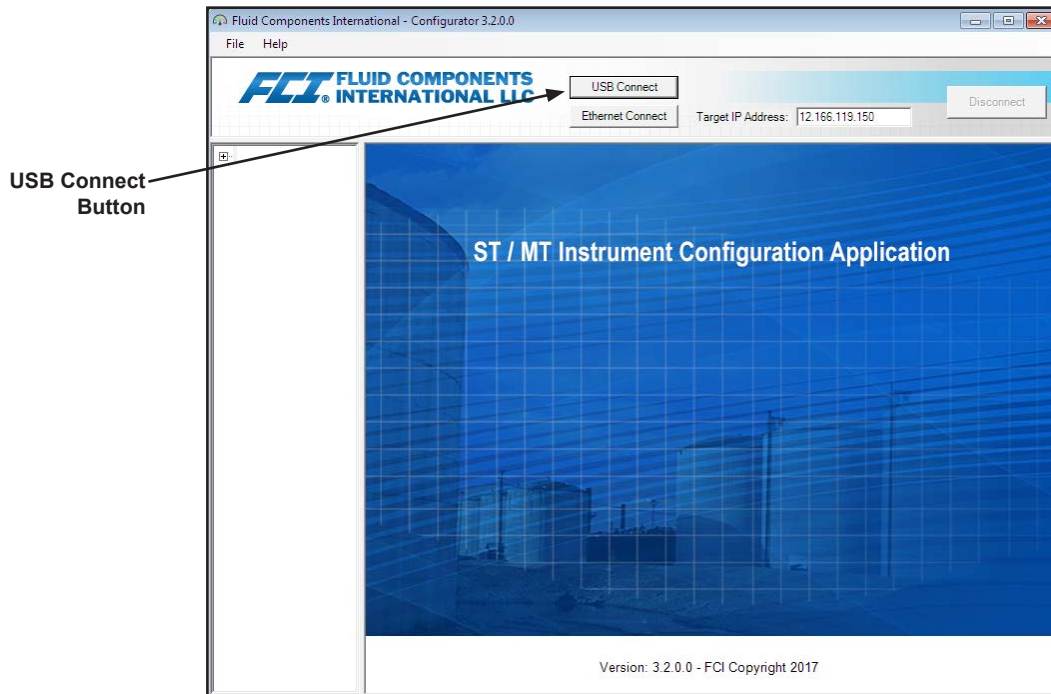

**Figure 1 – USB Connector on ST80/ST80L Main Board (Blind Lid Removed)**

**Note:** To avoid any connection problems make sure the ST80/ST80L is fully booted before connecting to the PC USB port and/or launching the ST80/ST80L configuration software.

**Caution:** A host PC connection to the ST80/ST80L is intended for temporary use only. Do not make the PC/network connection part of the permanent installation.

Double click the ST80/ST80L Configurator icon. The application opens to the Welcome screen as shown in the figure below. Click **USB Connect (Ethernet Connect does not apply to ST80/ST80L)** at the top of the screen to let the PC communicate with the instrument (with cable connection already made).



**Figure 2 – Welcome Screen**

Once connected, the application window shows the Process Data screen as shown in the figure below. The displayed information, which is the same as that shown on the HMI front panel display, includes the following:

- Flow as percent of range (scale)
- Flow with engineering units
- Total Flow (if Mass or Volumetric units used)
- Temperature
- Calibration Group **number** and Group **name**
- Alarm/Fault indicators

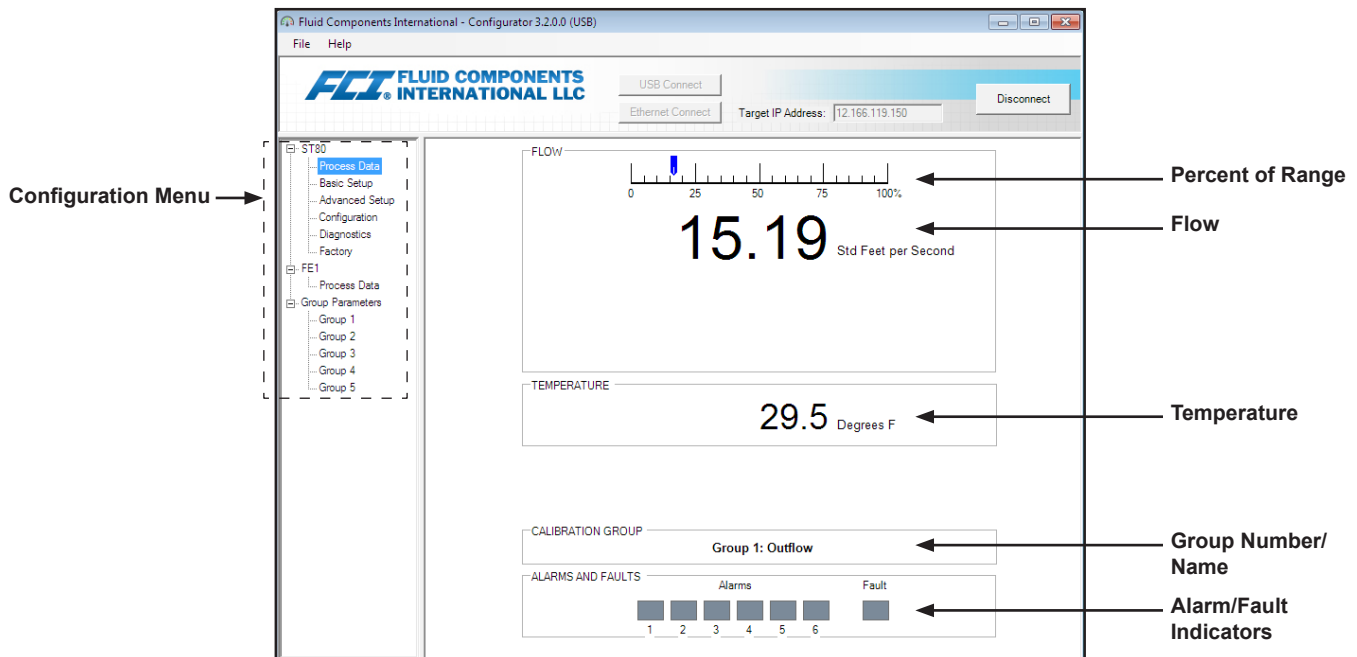
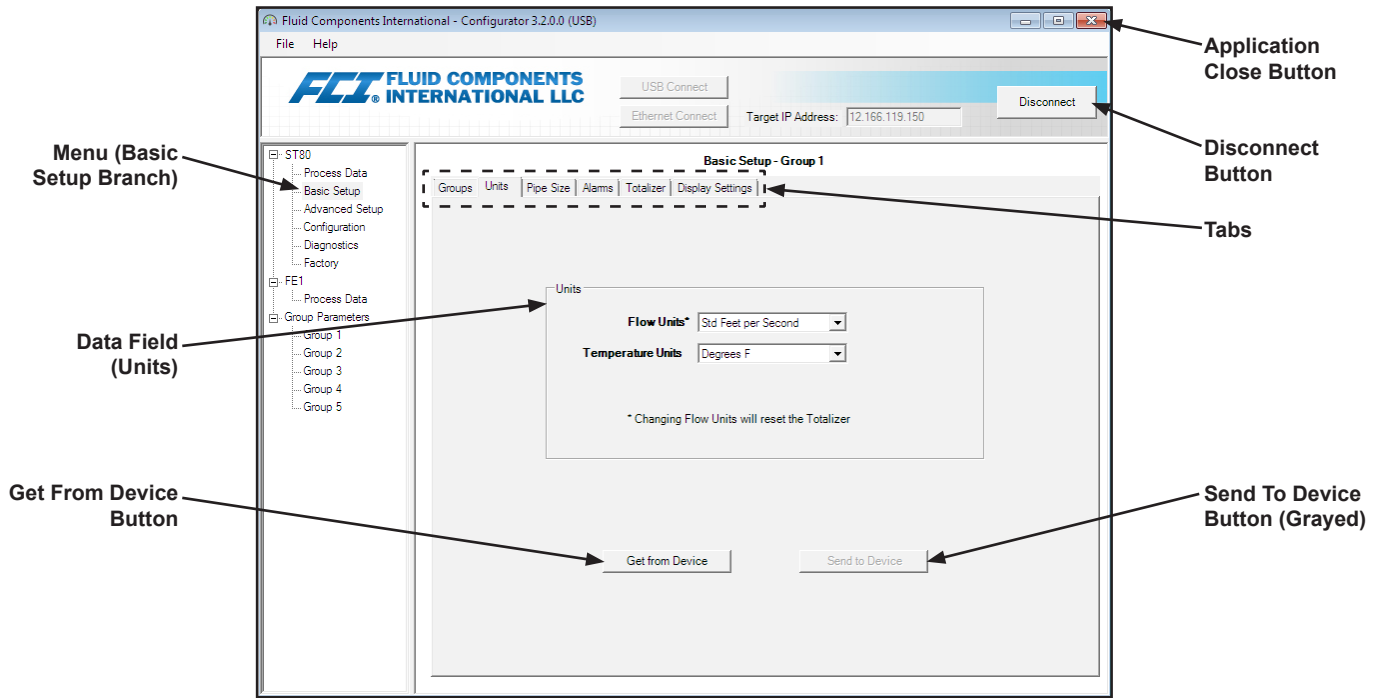

**Figure 3 – Example Process Data Screen**

**Configuration Software Basics**

The ST80/ST80L is set up using a configuration menu arranged in a hierarchical tree structure on the left side of the window. Select a menu item to see the related tabs on the right side of the window. Within the tab area parameter data is typically organized into one or more data fields, which are set off with a thin divider line or a thin box outline.

Many screens show **Get from Device** and/or **Send to Device** buttons at the bottom portion of the window. These buttons are shown if the window tab includes parameter data that can be retrieved from the instrument for display (**Get from Device**) and/or transmitted to the instrument for programming (**Send to Device**). The **Send to Device** button is normally grayed out (inactive) initially until a change is made in a data field. Once a parameter change is detected, the **Send to Device** button becomes active as shown by its solid appearance.



**Figure 4 – Basic Application Screen Elements**

Click **Disconnect** to break the connection between the PC and ST80/ST80L. Click the application window *Close* button or type ALT+F4 (with the application window having the focus) to quit the application altogether.

**Note:** Once the PC's configuration software is communicating with the instrument, some HMI display items/menus are inactive due to control being handed over to the configuration application. For example, front panel selection of groups via the **MENU** button is inactive (inactive HMI display menu items are shown with an asterisk).

**Password Protection**

To protect against unwanted/unauthorized change, two levels of password protection are provided: *User* and *Factory*. The User level password is associated with common user-accessed parameters that can only be changed after entering the User password. The Factory level password is associated with more sensitive programming that can only be modified by the factory or its representatives. The dialog box for password entry is shown below. When prompted, type the password and then click **OK**. The User password is: 2772. The password is also shown in this manual with the tab summary tables.

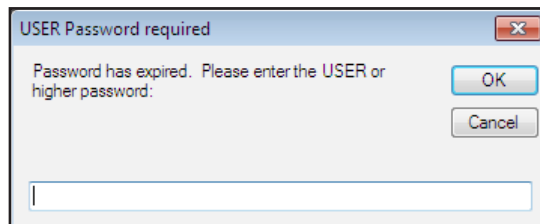

## Basic Setup Tab Screens

Select the **Basic Setup** branch on the menu tree to access basic setup items. The **Groups** tab is the first of several tabs across the top of the screen. Each tab provides a particular menu within the **Basic Setup** branch.

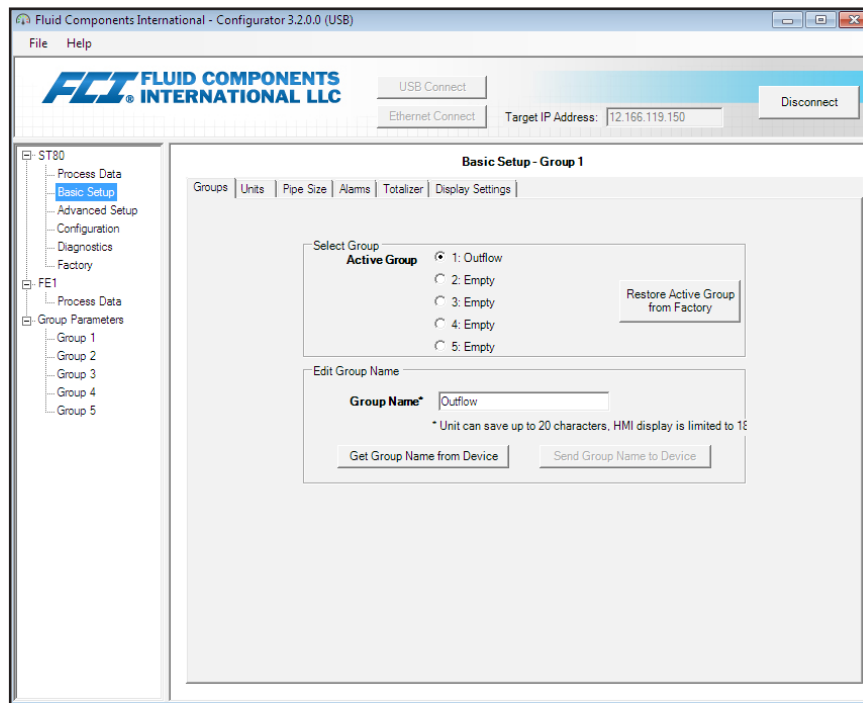

Figure 5 – Example Groups Tab (Basic Setup)

The table below summarizes the tabs within the **Basic Setup** branch.

Table 1 – Basic Setup Tabs

Tab Name	Tab Description	Password Level
Groups	Select and name groups. Switching between established groups takes place immediately once the radio button is clicked (no password required).	User
Units	Select flow and temperature units.	User
Pipe Size	Select pipe type and dimensions.	User
Alarms	Select and set alarm requirements.	User
Totalizer	Select and reset Totalizer requirements.	User
Display Settings	Adjust the HMI display. Tick the "Rotate Display 90 Degrees Clockwise" box and then click <b>Send To Device</b> to rotate the display 90 degrees (repeat as required). Move the Display Contrast slider as required (left = min.; right = max.) and then click <b>Send to Device</b> to change the display contrast.	User

[User password 2772]

To verify the current configuration of any setup parameter, click **Get from Device** on any of the Setup menus. After changing any of the setup parameters, click **Send to Device**. Click **Get from Device** again to verify the parameter(s) change. Observe that the changed parameters are now displayed. The remaining **Basic Setup** tab screens are shown below.



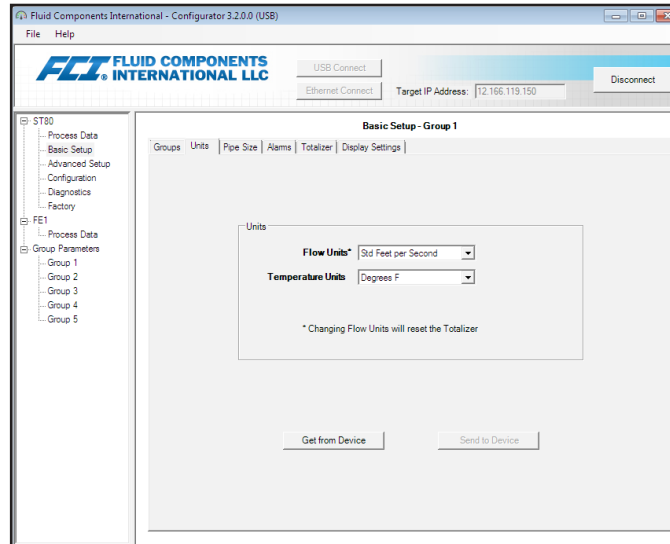

Figure 6 – Example Units Tab (Basic Setup)

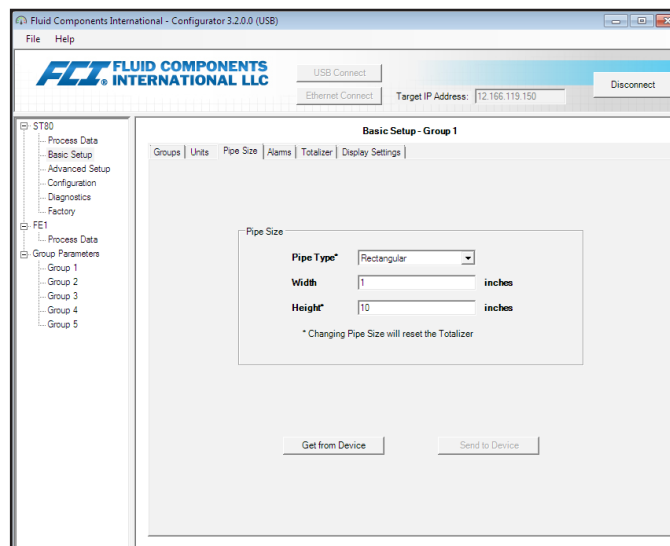

Figure 7 – Example Pipe Size Tab (Basic Setup)

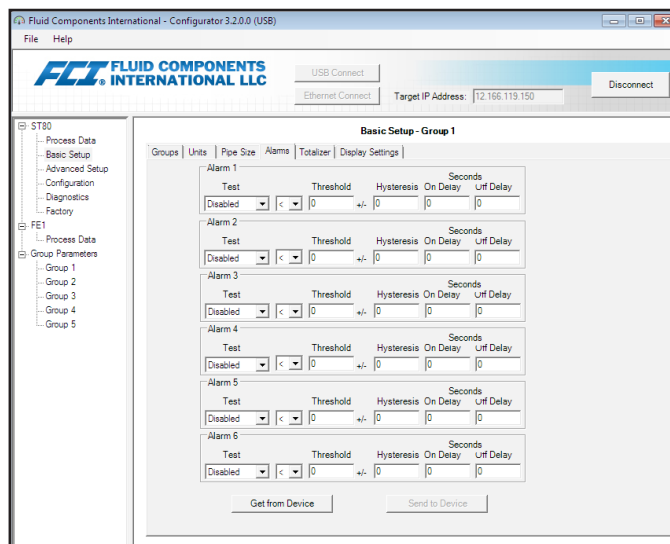

Figure 8 – Example Alarms Tab (Basic Setup)

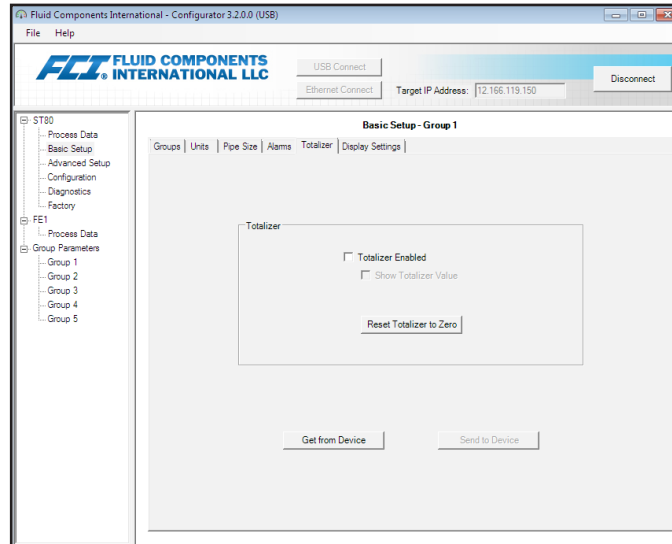

Figure 9 – Example Totalizer Tab (Basic Setup)

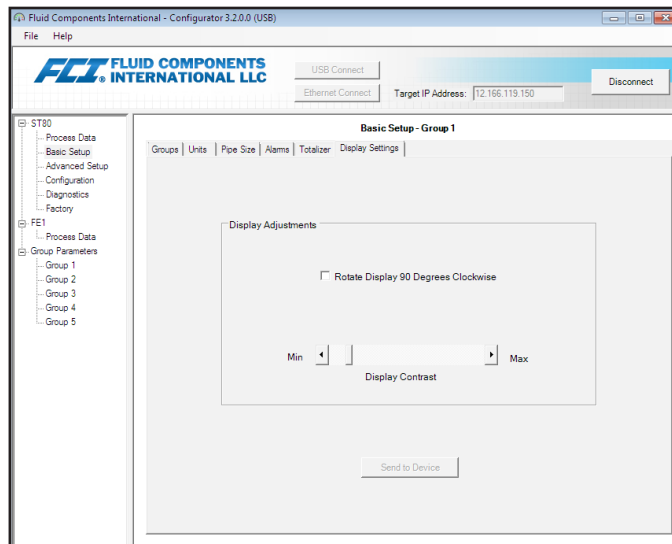

Figure 10 – Example Display Settings Tab (Basic Setup)

## Advanced Setup Tab Screens

Select the **Advanced Setup** branch on the menu tree to access advanced setup items. The **User Parameters** tab is the first of several tabs across the top of the screen. Each tab provides a particular menu within the **Advanced Setup** branch.

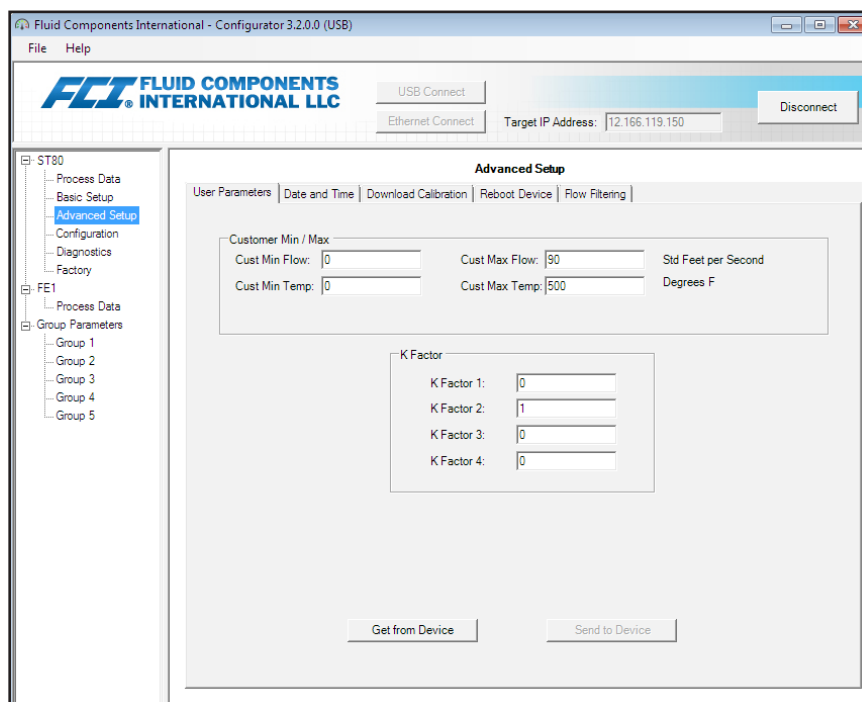

Figure 11 – Example User Parameters Tab (Advanced Setup)

The table below summarizes the tabs within the **Advanced Setup** branch.

Table 2 – Advanced Setup Tabs

Tab Name	Tab Description	Password Level
User Parameters	Shows min/max process variable limits and K Factor.	User
Date and Time	In the <i>Date and Time</i> field, set the date using the drop down calendar date picker and the time using the spinner controls. Alternatively, click <b>Set to System Date/Time</b> to copy the host PC system's date/time and transmit it to the instrument's battery-backed real time clock.	User
Download Calibration	Lets users download a full calibration to their ST80/ST80L via a text file. Contact FCI to obtain the .txt file that was generated by the factory linearization software (Cal2). See "Download Calibration" on page 8 for details on how to download the calibration file.	User
Reboot Device	Click <b>Reboot Device</b> to perform a warm boot of the ST80/ST80L. Be aware that rebooting the instrument affects device outputs and interrupts communications.	User
Flow Filtering	Sets flow filtering via Flow Output Damping <sup>1</sup> and/or Flow Input Moving Average Filter <sup>2</sup> . Refer to <b>Flow Filtering</b> in main manual <b>06EN003490</b> for details on these features.	User

Note 1. Flow damping smooths out flow signal output. Flow response is reduced with high flow damping values.

Note 2. The flow input moving average filter smooths out the input flow signal using a moving average (boxcar) filter that averages the last X number of readings.

[User password 2772]

To verify the current configuration of any setup parameter, click **Get from Device** on any of the Setup menus. After changing any of the setup parameters, click **Send to Device**. Click **Get from Device** again to verify the parameter(s) change. Observe that the changed parameters are now displayed. The remaining **Advanced Setup** tab screens are shown below.

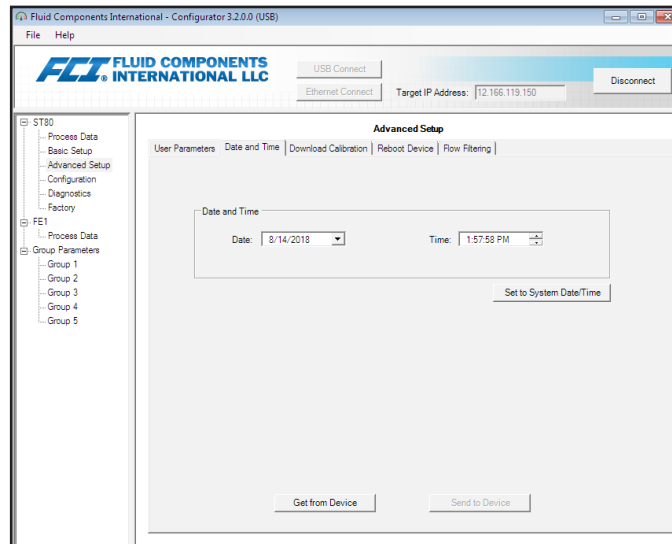

Figure 12 – Example Data and Time Tab (Advanced Setup)

### Download Calibration

Follow these steps to download the calibration file directly to the instrument.

1. In the *Get Calibration File* field, click **Browse...**
2. Observe that an Open File dialog appears. Navigate to the Cal2-generated text file's directory/folder (local drive or network), select the appropriate file, and then click **Open**. Observe that the text box shows the file's path.
3. In the *Select Group For Download* field, use the drop down list to select the applicable group.
4. In the *Select FE For Download* field, use the drop down list to select the FE (FE1 is the only choice for ST80/ST80L).
5. Click **Send to Device** (enter User password as required).

**Note:** The calibration file is a text file with the following default filename format:

**SerialNo\_CustomerNo\_CalGroup\_FE/Head.txt.**

Example: For an instrument with serial number 492890, customer number C076370, calibration group 1, and a single FE/head, the calibration file filename would be: *492890\_C076370\_1\_1.txt*.

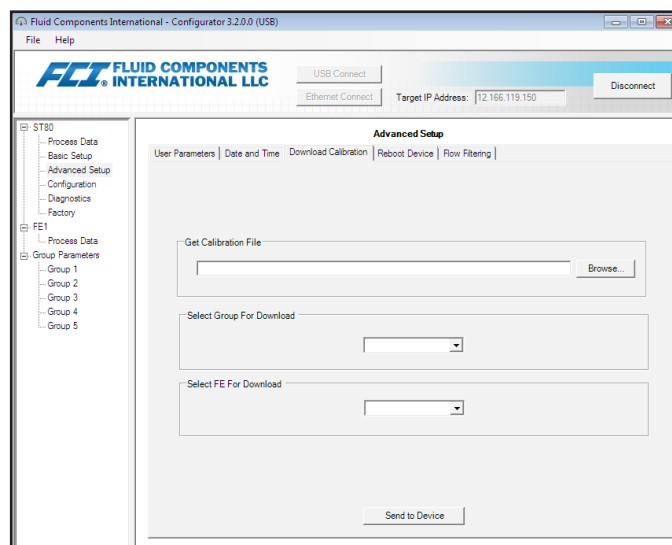

Figure 13 – Example Download Calibration Tab (Advanced Setup)

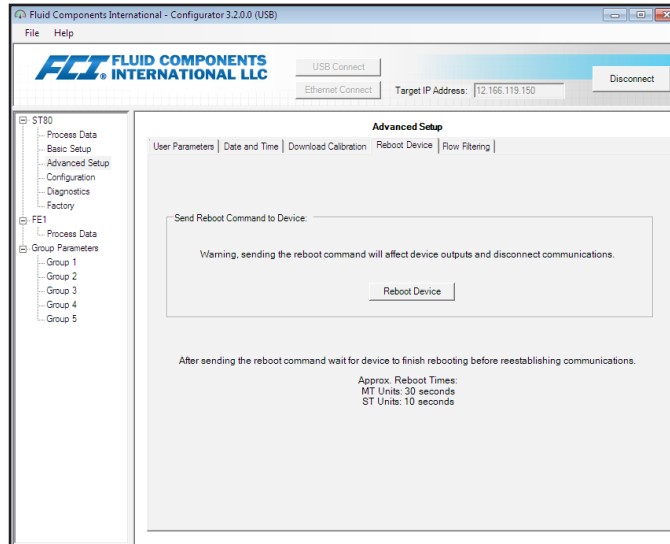

Figure 14 – Example Reboot Device Tab (Advanced Setup)

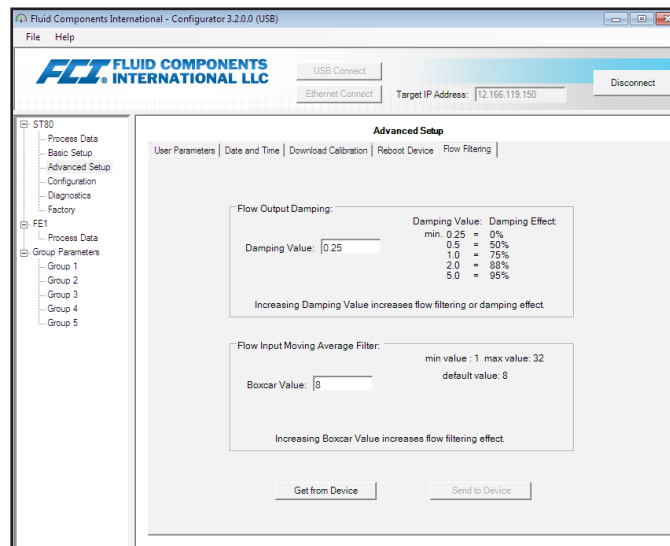

Figure 15 – Example Flow Filtering Tab (Advanced Setup)

## Configuration Tab Screens

Select the **Configuration** branch on the menu tree to access configuration setup items. The **Output** tab is the first of several tabs across the top of the screen. Each tab provides a particular menu within the **Configuration** branch.

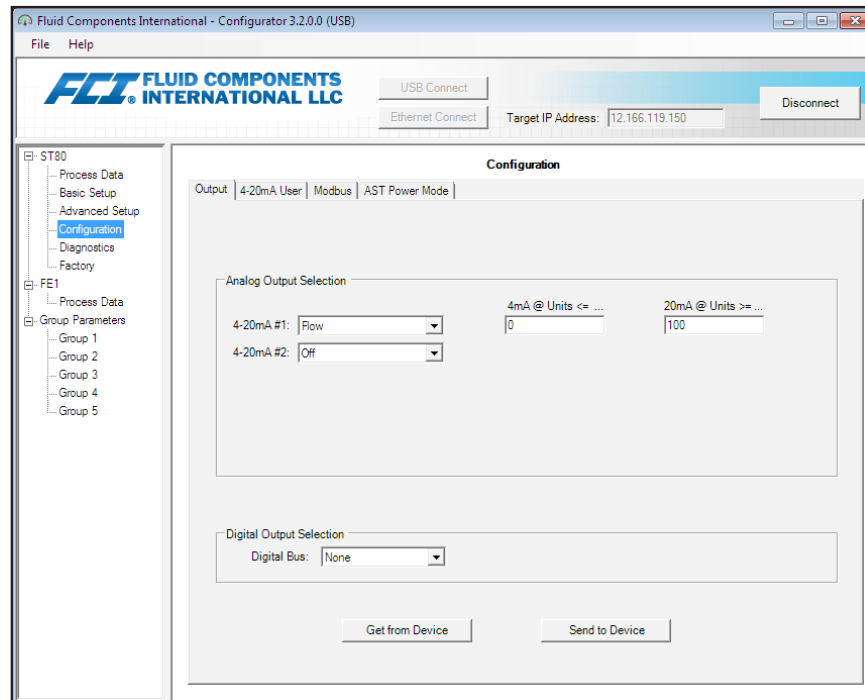

Figure 16 – Example Output Tab (Configuration)

The table below summarizes the tabs within the **Configuration** branch.

Table 3 – Configuration Tabs

Tab Name	Tab Description	Password Level
Output	Sets: 4-20 mA channels parameter and units assignment <sup>1</sup> , and digital bus selection (Modbus or FF/Profibus) <sup>2</sup> .	User
4-20 mA User	Manual mA Output loop check; configure/enable NAMUR fault. Note that an analog output must be set to <b>Flow</b> (in <i>Output</i> tab) for NAMUR parameters (including enable/disable checkbox) to display for that channel.	User
Modbus	Sets Modbus communication parameters.	User
AST Power Mode	Sets heater mode (AST or Constant Power) and max. heater current for AST (90 mA or 105 mA). The max. current value forms the threshold at which the instrument transitions to/from Constant Power mode. See <i>Configuring the ST80/ST80L for AST™ or Constant Power Measurement Methods</i> in the Operation section of main manual <b>06EN003490</b> for more information. Note that <i>VC</i> and <i>VD</i> data is for factory use only.	User

Note 1. To set **HART** operation, select *HART Flow* from 4-20 mA #1 drop-down list (in *Analog Output Selection* field).

Note 2. Digital busses (includes HART, Modbus, and FF/Profibus) are mutually exclusive, meaning only one can be active at a time. Attempting to enable HART when Modbus or FF/Profibus is in effect causes the Digital Bus Deactivation Warning dialog to display: Click **OK** to make the change and force the Digital Output Selection to *None* or click **Cancel** to leave the setting unchanged. Attempting to enable Modbus or FF/Profibus when HART is in effect causes the HART Deactivation Warning dialog to display: Click **OK** to make the change and force the 4-20 mA #1 Selection to *Flow* or click **Cancel** to leave the setting unchanged.

[User password 2772]

To verify the current configuration of any setup parameter, click **Get from Device** on any of the Setup menus. After changing any of the setup parameters, click **Send to Device**. Click **Get from Device** again to verify the parameter(s) change. Observe that the changed parameters are now displayed. The remaining **Configuration** tab screens are shown below.

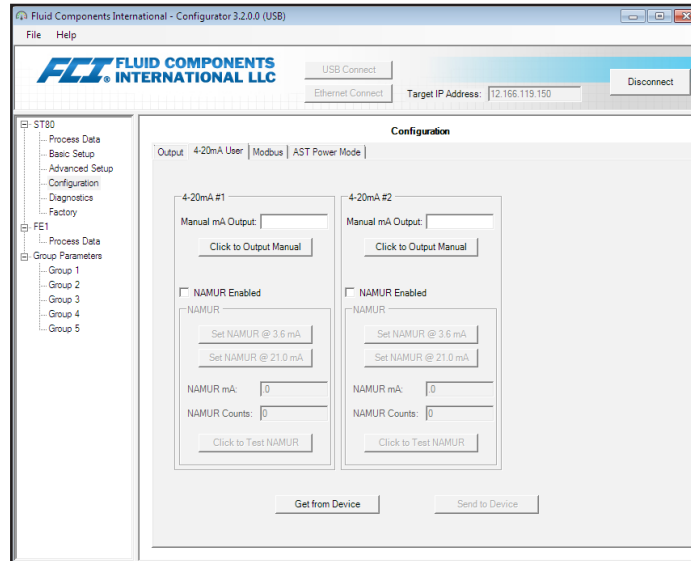

Figure 17 – Example 4-20 mA User Tab (Configuration)

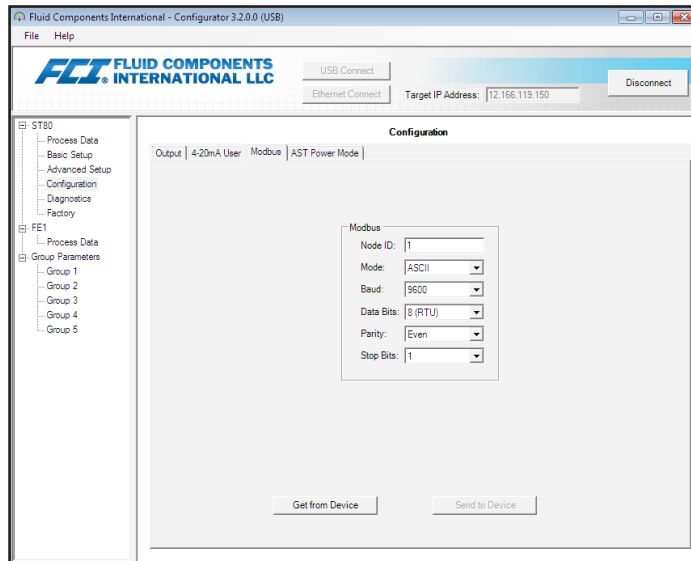

Figure 18 – Example Modbus Tab (Configuration)

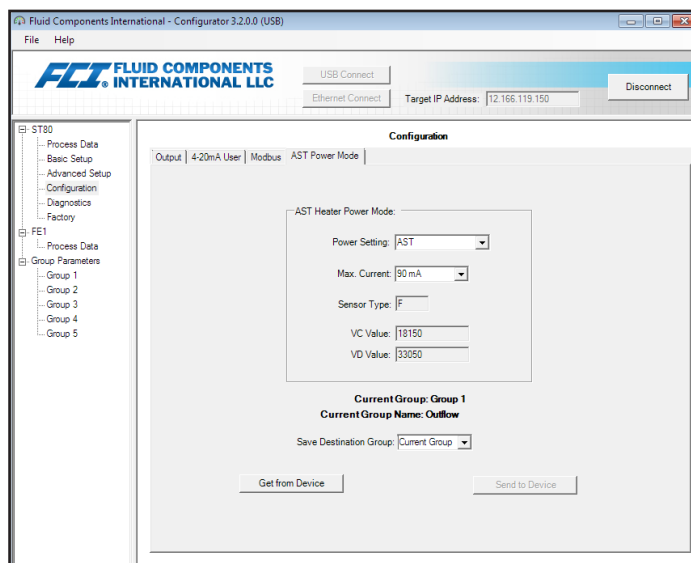

Figure 19 – Example AST Power Mode Tab (Configuration)

## Diagnostics Tab Screens

Select the **Diagnostics** branch on the menu tree to access diagnostic items. The **Status** tab is the first of several tabs across the top of the screen. Each tab provides a particular menu within the **Diagnostics** branch. The table below summarizes the tabs within the **Diagnostics** branch.

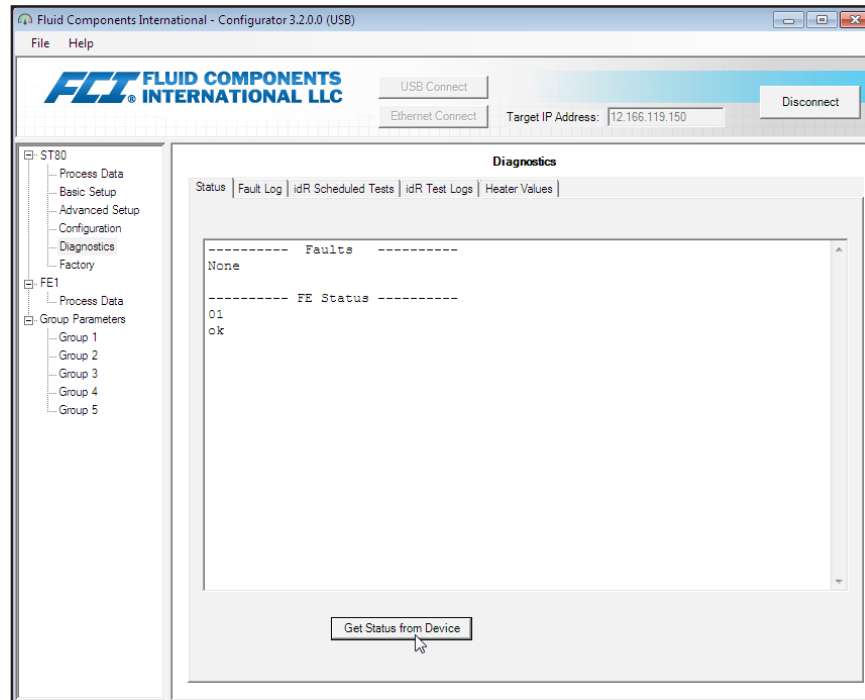

Figure 20 – Example Status Tab (Diagnostics)

Table 4 – Diagnostics Tabs

Tab Name	Tab Description	Password Level
Status	Indicates system status and fault flags. Click <b>Get Status from Device</b> to display the status.	Read only
Fault Log	Shows fault history. Click <b>Get Fault Logs from Device</b> to list the faults in the scrollable text box. Click <b>Clear Fault Log</b> to clear the log.	User
idR Scheduled Tests	For internal Delta R (idR) resistance check – Set pass/fail criteria, set FE1 output mode during test, schedule periodic idR test, display previous idR test results, and start idR test on-demand. Test results display in <b>FE1 idR Test Results</b> field (table format) when done. See <i>Running the idR Check Using the ST80/ST80L Configuration Software</i> in the Operation section of main manual <b>06EN003490</b> for more details on this screen.	User
idR Test Logs	Click <b>Get Test Log from Device</b> to show idR test results in the scrollable text box. Click <b>Clear Test Logs</b> to clear the log.	User
Heater Values	Shows heater status for the selected FE. Data shown includes heater resistance, heater voltage, and heater current (in mA). Click <b>Start Data Loop</b> to start the measurements for heater status.	User

[User password 2772]

The remaining **Diagnostics** tab screens are shown below.



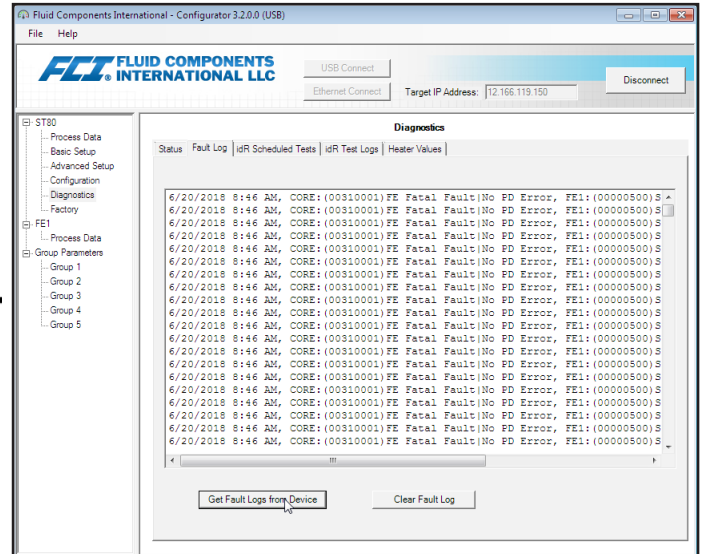
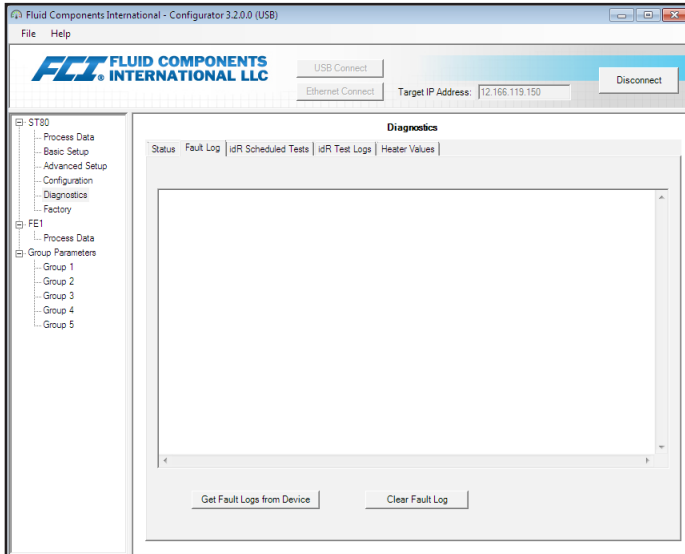

Figure 21 – Example Fault Log Tab and Example Fault Log List (Diagnostics)

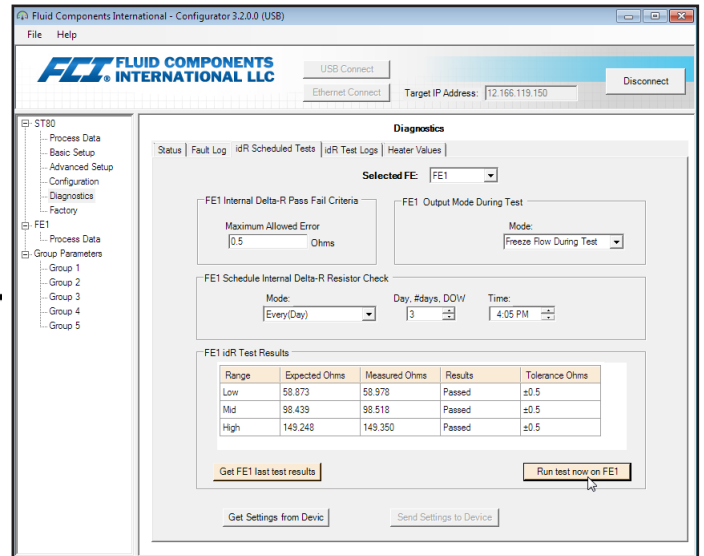
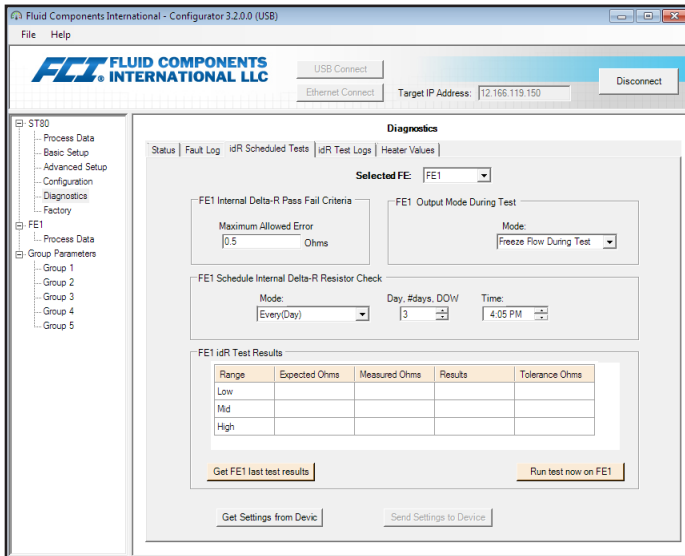

Figure 22 – Example idR Scheduled Tests Tab and Example idR On-Demand Test Results Display (Diagnostics)

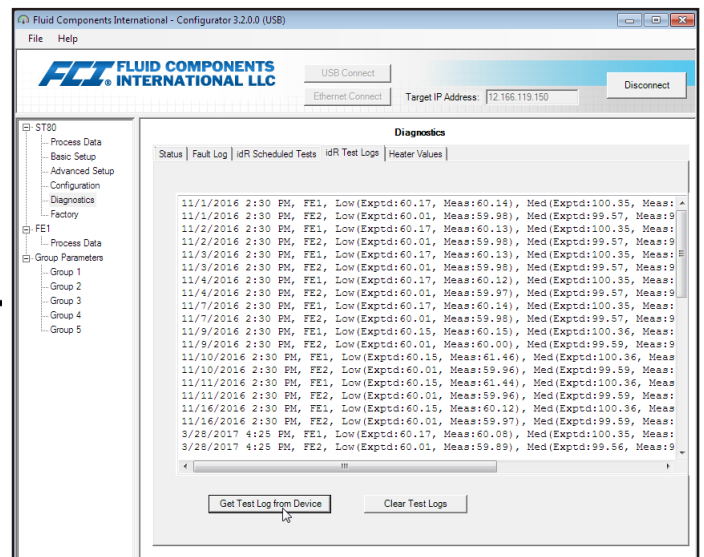
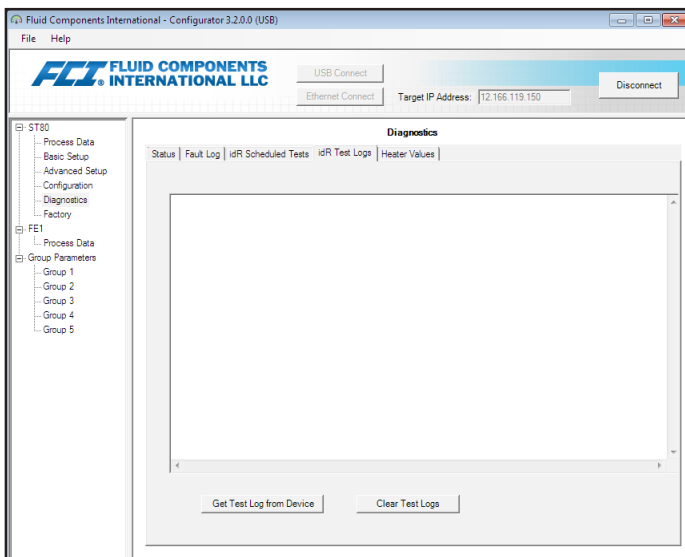

Figure 23 – Example idR Test Logs Tab and Example idR Test Log List (Diagnostics)

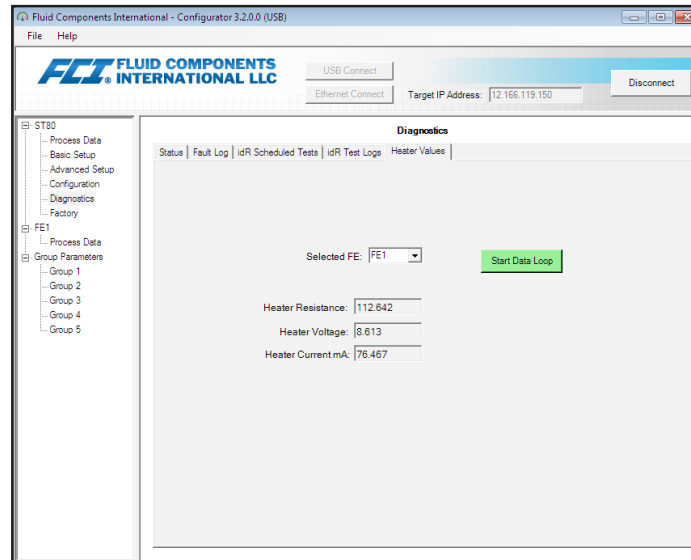

Figure 24 – Example Heater Values Tab (Diagnostics)

## Factory Tab Screens

The **Factory** branch on the menu tree provides factory-only setup items. Only the factory or its representatives can change data in this group.

Table 5 – Factory Tabs

Tab Name	Tab Description	Password Level
Factory Parameters	Factory use only. (Calibrated Min/Max data.)	Factory
Identification	Factory use only. (Instrument ID data.)	Factory
4-20mA Factory	Factory use only. (4-20 mA output DAC count scaling and manual output control.)	Factory
Options	Factory use only. (Option inventory: display configuration, FE configuration [Fixed at FE1 for ST80/ST80L].)	Factory
HART	Factory use only. (HART ID info: electronics revision, HART ID, int. HART rev.)	Factory
Memory	Factory use only. (Erase various memory spaces.)	Factory
Reset idRs	Factory use only. (Click <b>Run FE1 idR Check</b> for selected FE [fixed at FE1 for ST80/ST80L], and then click <b>Reset Expected idR Values</b> to set displayed <i>Measured Ohms</i> values as new baseline for <i>Expected Ohms</i> values [observe that values in the <i>Internal dR Check Values</i> field disappear after <b>Reset Expected idR Values</b> is clicked].)	Factory
SIL Adj	Factory use only. (Adjusts calibration for accurate reading of power supply voltages [+24 VDC, +5 VDC] and 4-20 mA Output #1.)	Factory
FE Faults	Factory use only. (Click <b>Get Current FE1 Faults</b> to display all possible FE faults with enable and/or trip status. In the screen's <i>Enabled</i> column, make any fault enable/disable change by checking (fault enabled) or unchecking (fault disabled) the box and then clicking <b>Send FT Enabled Map Changes</b> (requires Factory level password).	Factory
Core Faults	Factory use only. (Click <b>Get Current Faults</b> to display all possible core faults with trip status. The Core Faults screen shows <i>Pressure Data Error</i> as tripped by default. This is normal since the ST80/ST80L is not pressure-capable.)	Factory

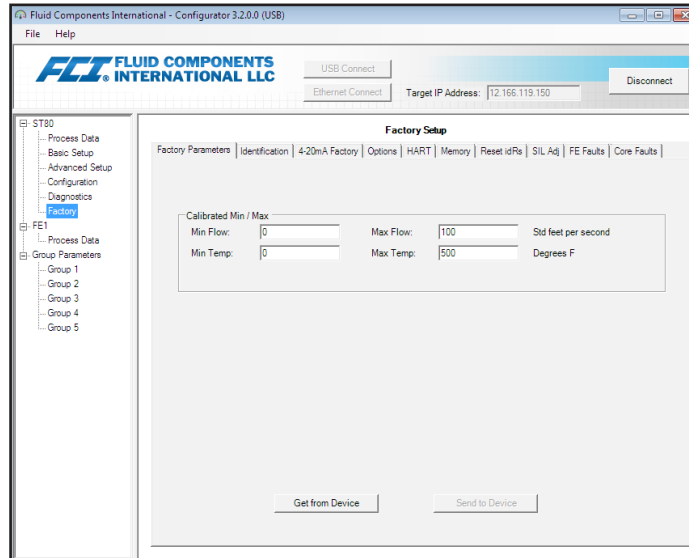

Figure 25 – Example Factory Parameters Tab (Factory)

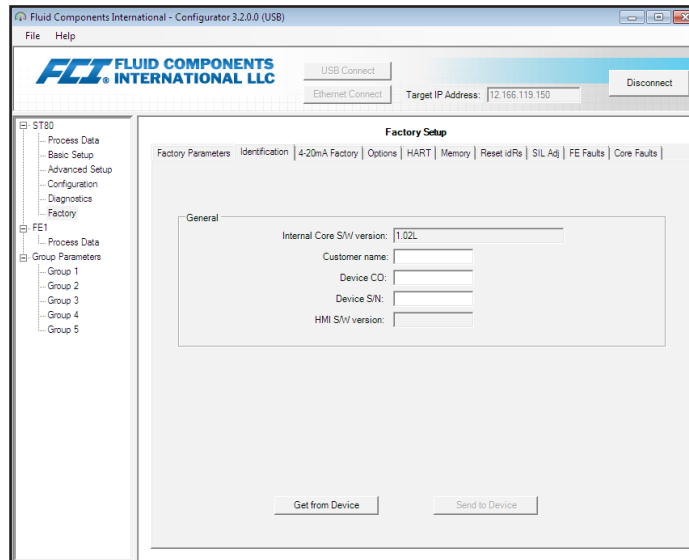

Figure 26 – Example Identification Tab (Factory)

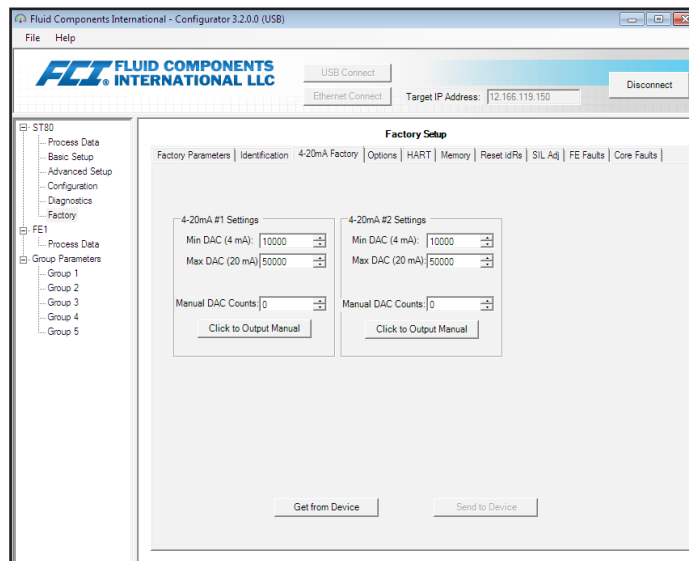

Figure 27 – Example 4-20mA Factory Tab (Factory)

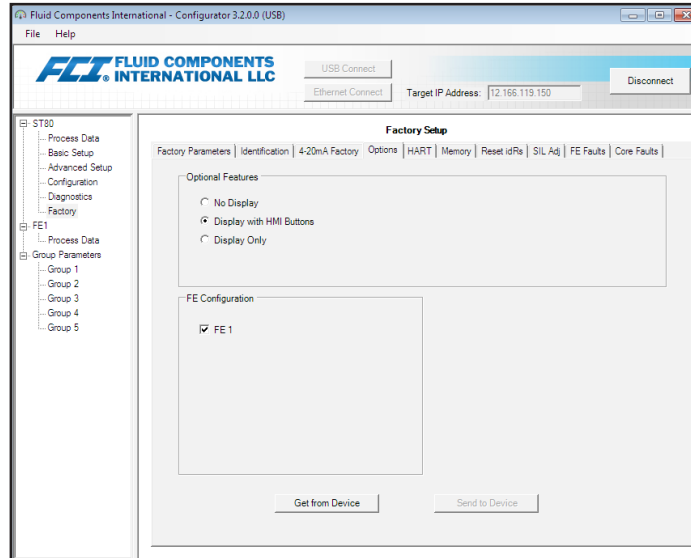

Figure 28 – Example Options Tab (Factory)

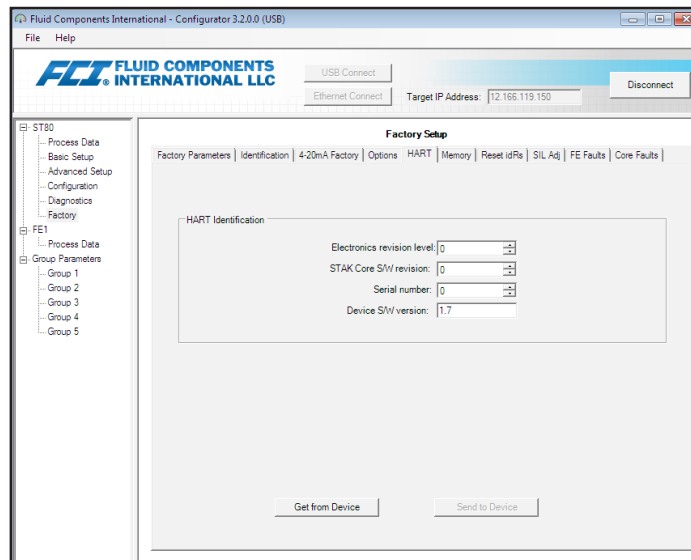

Figure 29 – Example HART Tab (Factory)

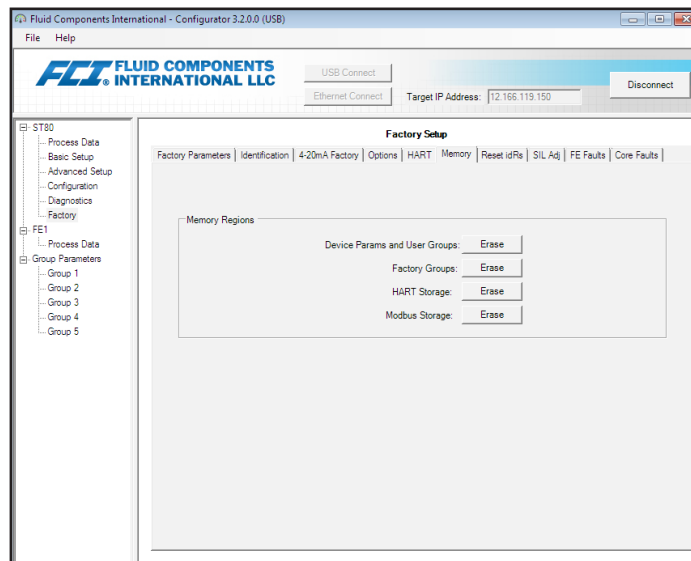

Figure 30 – Example Memory Tab (Factory)

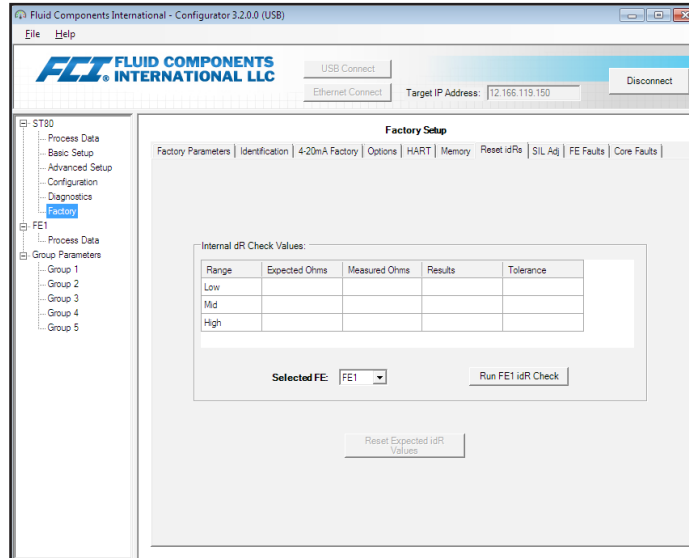

Figure 31 – Example Reset idRs Tab (Factory)

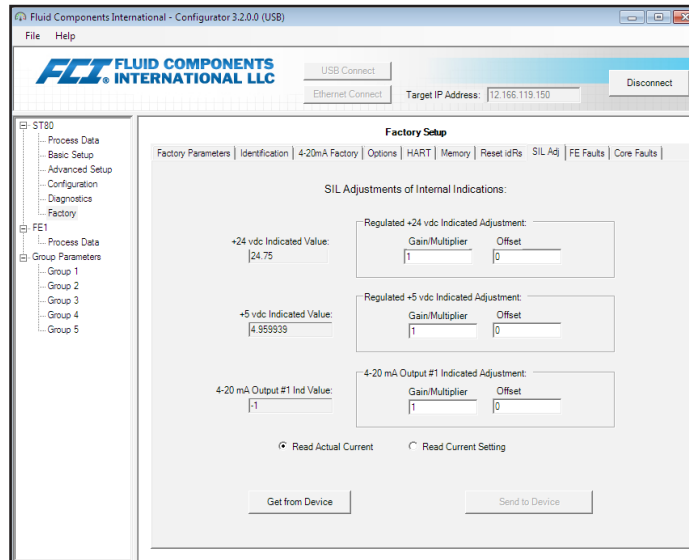

Figure 32 – Example SIL Adj Tab (Factory)

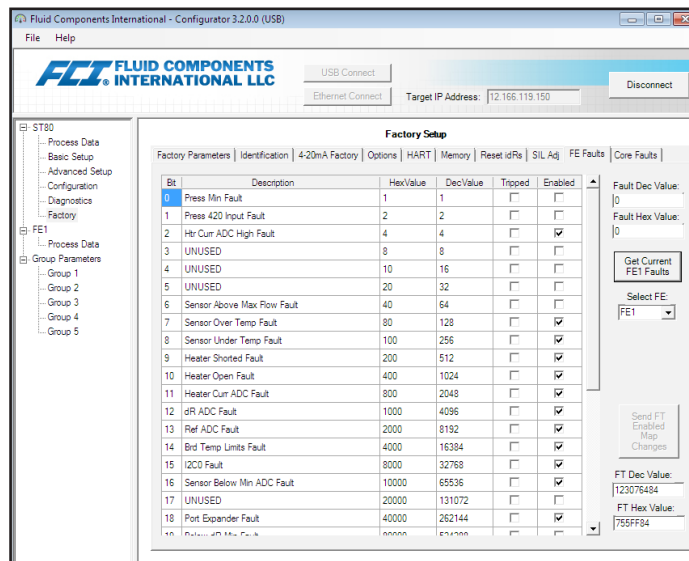

Figure 33 – Example FE Faults Tab (Factory)

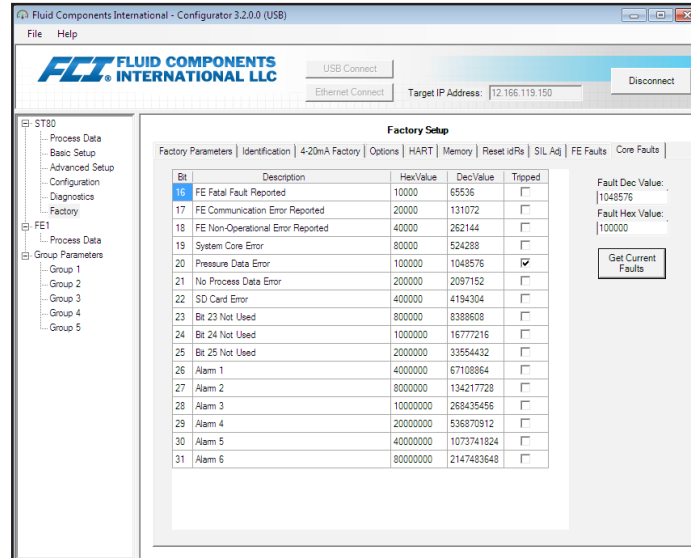

Figure 34 – Example Core Faults Tab (Factory)

## FE1 Process Data

Select the **FE1 Process Data** branch on the menu tree. The figure below shows an example FE1 Process Data screen. This screen displays the real time values of the following flow element parameters:

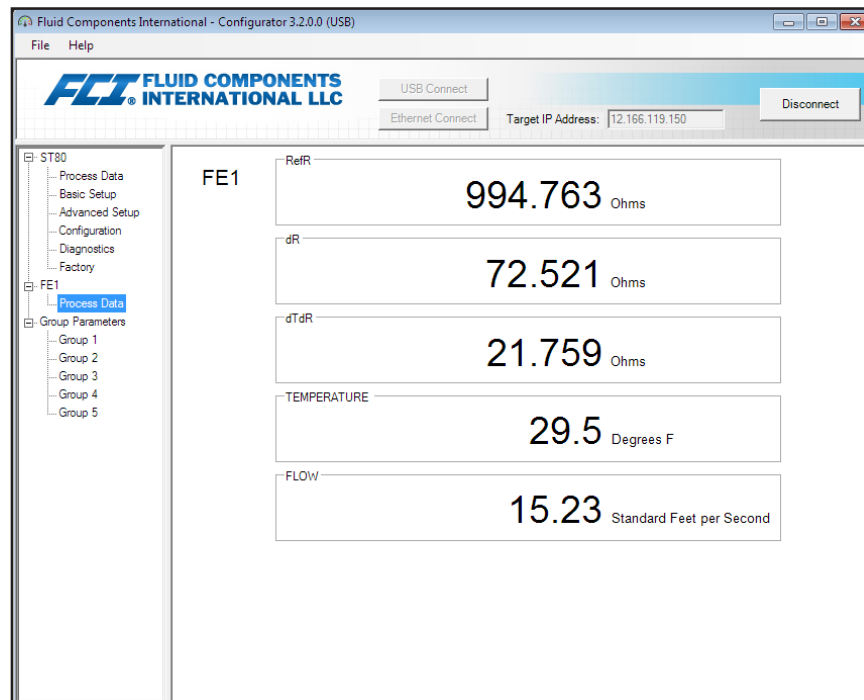

Figure 35 – Example Process Data Screen (FE1)

- RefR – Reference RTD resistance
- dR – Delta resistance between the active and reference RTDs
- dTdR – Delta-T/Delta-R resistance, variable relative to process flow rate
- Temperature – Real time temperature value
- Flow – Real time flow value

This screen can be helpful when diagnosing system faults.

**Parameter Reports**

A **Parameter Reports** screen (under *Group Parameters* in the menu tree) displays the calibration and configuration information saved in the ST80/ST80L unit for a particular calibration group numbered 1-5. Selecting a parameter report for a particular calibration group displays that group's info/data. As required, make a parameter change using the alphanumeric data entry field in the Parameter Value column. Similar to other setup menus there is a **Send Changes to Device** button to transmit any parameter change to the ST80/ST80L. Use of the **Send** button, however, requires the Factory level password.

**Note:** Some listed parameters are not applicable depending on the instrument model/configuration.

Destination	Parameter Name	CLI	Parameter Value
CORE	Date and Time:	RC	9/4/2018 2:26:50 PM
CORE	Unit Serial Number:	2Y	
CORE	Cust Number:	2X	
CORE	Cust Name:	CU	
CORE	Core Version:	4V	1.02L
CORE	HMI Version:	7Q	
CORE	MAC Address:	4R	1E:30:6C:A2:45:5E
CORE	HART Serial Number:	2S	0
CORE	Ext Op Mode:	8R	1
CORE	Ext Op Submode:	8R	0
CORE	4-20mA Inp Adj Gain:	8S	1
CORE	4-20mA Inp Adj Offset:	8S	0
CORE	EFI Flow Min.:	8T	0
CORE	EFI Flow Max.:	8T	0
CORE	EFI Flow Units:	8T	0
CORE	EGS Threshold1:	8U	0
CORE	EGS Group1 ID:	8U	0
CORE	EGS Threshold2:	8U	0
CORE	EGS Group2 ID:	8U	0
CORE	EGS Threshold3:	8U	0
CORE	EGS Group3 ID:	8U	0
CORE	EGS Threshold4:	8U	0
CORE	EGS Group4 ID:	8U	0
CORE	EGS Group5 ID:	8U	0

**Figure 36 – Example Parameter Report, Group 1**

Destination	Parameter Name	CLI	Parameter Value
CORE	Date and Time:	RC	9/4/2018 2:29:36 PM
CORE	Unit Serial Number:	2Y	
CORE	Cust Number:	2X	
CORE	Cust Name:	CU	
CORE	Core Version:	4V	1.02L
CORE	HMI Version:	7Q	
CORE	MAC Address:	4R	1E:30:6C:A2:45:5E
CORE	HART Serial Number:	2S	0
CORE	Ext Op Mode:	8R	1
CORE	Ext Op Submode:	8R	0
CORE	4-20mA Inp Adj Gain:	8S	1
CORE	4-20mA Inp Adj Offset:	8S	0
CORE	EFI Flow Min.:	8T	0
CORE	EFI Flow Max.:	8T	0
CORE	EFI Flow Units:	8T	0
CORE	EGS Threshold1:	8U	0
CORE	EGS Group1 ID:	8U	0
CORE	EGS Threshold2:	8U	0
CORE	EGS Group2 ID:	8U	0
CORE	EGS Threshold3:	8U	0
CORE	EGS Group3 ID:	8U	0
CORE	EGS Threshold4:	8U	0
CORE	EGS Group4 ID:	8U	0
CORE	EGS Group5 ID:	8U	0

**Figure 37 – Example Parameter Report, Group 5**





## **Customer Service/Technical Support**

FCI provides full in-house technical support. Additional technical representation is also provided by FCI field representatives.

### ***By Mail***

Fluid Components International LLC  
1755 La Costa Meadows Dr.  
San Marcos, CA 92078-5115 USA  
Attn: Customer Service Department

### ***By Phone***

Contact the area FCI regional representative. If a field representative is unable to be contacted or if a situation is unable to be resolved, contact the FCI Customer Service Department toll free at 1 (800) 854-1993.

### ***By Fax***

To describe problems in a graphical or pictorial manner, send a fax including a phone or fax number to the regional representative. Again, FCI is available by facsimile if all possibilities have been exhausted with the authorized factory representative. Our fax number is 1 (760) 736-6250; it is available 7 days a week, 24 hours a day.

### ***By Email***

FCI Customer Service can be contacted by email at: [techsupport@fluidcomponents.com](mailto:techsupport@fluidcomponents.com).

Describe the problem in detail making sure a telephone number and best time to be contacted is stated in the email.

### ***International Support***

For product information or product support outside the contiguous United States, Alaska, or Hawaii, contact your country's FCI International Representative or the one nearest to you.

### ***After Hours Support***

For product information visit the FCI website at [www.fluidcomponents.com](http://www.fluidcomponents.com). For product support call 1 (800) 854-1993 and follow the pre-recorded instructions.

### ***Point of Contact***

The point of contact for service, or return of equipment to FCI is your authorized FCI sales/service office. To locate the office nearest you, visit the FCI website at [www.fluidcomponents.com](http://www.fluidcomponents.com).



*Flow & Level Instrumentation  
Solutions for Industrial Processes*

**FCI's Complete Customer Commitment. Worldwide  
ISO 9001 and AS9100 Certified**

Visit FCI on the Worldwide Web: [www.fluidcomponents.com](http://www.fluidcomponents.com)

**FCI World Headquarters**

1755 La Costa Meadows Drive | San Marcos, California 92078 USA | Phone: 760-744-6950 Toll Free (US): 800-854-1993 Fax: 760-736-6250

**FCI Europe**

Persephonestraat 3-01 | 5047 TT Tilburg, The Netherlands | Phone: 31-13-5159989 Fax: 31-13-5799036

**FCI Measurement and Control Technology (Beijing) Co., LTD | [www.fluidcomponents.cn](http://www.fluidcomponents.cn)**

Room 107, Xianfeng Building II, No.7 Kaituo Road, Shangdi IT Industry Base, Haidian District | Beijing 100085, P. R. China  
Phone: 86-10-82782381 Fax: 86-10-58851152

**Notice of Proprietary Rights**

This document contains confidential technical data, including trade secrets and proprietary information which is the property of Fluid Components International LLC (FCI). Disclosure of this data to you is expressly conditioned upon your assent that its use is limited to use within your company only (and does not include manufacture or processing uses). Any other use is strictly prohibited without the prior written consent of FCI.