

FS10i Air/Compressed Air Flow Meter

**SIL 2
Compliance Rating**



In-line pipe tee for 1" and 2" diameter pipes (left)

1/2" NPT adjustable compression fitting; 6" [152 mm] or 12" [305 mm] length (right)

- Paint Booth Ventilation
- Compressed Air Leak Detection
- Packaging and Wrapping Machinery Air Flow
- Clean Room Air Flow
- Burner, Furnace and Boiler Intake Air

The FS10i is a compact, economical solution to air and compressed air flow metering. Utilizing application proven thermal dispersion technology, the FS10i provides a highly accurate and repeatable linearized 4-20mA output of flow rate. Additionally, for applications benefiting from a high or low flow alarm point, the FS10i includes a user programmable 1A SPDT relay output.

The FS10i flow meter is designed for use in air or compressed air line sizes from 1 inch to 20 inches [25 mm to 500 mm]. For line sizes of 1 inch or 2 inch [25 mm or 50 mm] an in-line pipe tee is provided to ensure the instrument's accuracy and repeatability in the installation. The stainless steel pipe tee and female NPT threads allow for easy, secure installation in the pipe run. For line sizes 2 1/2 inch [63,5 mm] or larger, select the insertion-style FS10i. The insertion-style is offered in two probe lengths, either 6 inch or 12 inch [152 mm or 305 mm]. These are outfitted with 1/2 inch compression fitting to adjust the actual insertion depth to be compatible with a range of pipe diameters and installation variables to achieve inserting the sensor element to the center-point of the pipe. User set-up, via the PC interface and free FCI software utility program, includes scaling the 4-20mA output to desired flow range, setting the relay trip point, adding hysteresis or time delay to the relay's action, etc. For visual indication the FS10i includes a 10-segment LED array that illuminates proportionally to the flow rate as well as will start flashing if

an alarm trip occurs.

The FS10i is currently the only thermal mass flow meter with a SIL 2 compliance rating. The FS10i is precision calibrated on FCI's air flow stands which are outfitted with NIST and ISO/IEC 17025 traceable equipment that ensure its accuracy and your confidence in using it.

If your air or compressed air flow meter criteria include low cost, easy installation, and little, to no, routine maintenance, FCI's FS10i is your solution.

FS10i Features

- Direct Mass Flow Measurement
- Ultra Reliable, No Moving Parts Design
- User-Programmable 4-20mA Output and Relay Trip Point
- 10 LED Display Array
- Easy M12 or Cable Gland Connection to Electronics
- SIL 2 Compliance Rating
- Optional Div 2/Zone 2 Approvals

FS10i Specifications

Instrument

Measuring Principal: Thermal dispersion

Fluid Type: Air, compressed air

Accuracy: $\pm 1.5\%$ rdg, $\pm 0.5\%$ FS

Process Connections

In-line: 1" or 2" pipe tee, FNPT threads

Insertion: 1/2" MNPT compression fitting with either Teflon or metal ferrule

Repeatability: $\pm 0.5\%$ of reading

Response Time: 4 sec. (1 time constant)

Temperature Coefficient For temperatures $> \pm 30^\circ\text{F}$ [$\pm 16^\circ\text{C}$]

Maximum $\pm 0.025\%$ of reading/ $^\circ\text{F}$ up to 250°F [$\pm 0,05\%$ of reading/ $^\circ\text{C}$ up to 121°C]

Flow Element

Materials of Construction (Wetted Parts)

In-line: 316 stainless steel pipe tee; 316L stainless steel flow element with Hastelloy C-22 thermowells

Insertion: 316L stainless steel with Hastelloy-C22 thermowells

Operating Temperature

-40°F to 250°F [-40°C to 121°C]

Teflon ferrule maximum temperature is 200°F [93°C]

FS10i specifications continued on next page

Operating Pressure

In-line: 225 psi [15,5 bar]

Insertion: 500 psi [34 bar]

Teflon ferrule maximum pressure is 150 psig [10 bar(g)]

Insertion "U" lengths

6" [152 mm] with variable insertion depth, 1/2" MNPT compression fitting with Teflon or metal ferrule

12" [305 mm] with variable insertion depth, 1/2" MNPT compression fitting with Teflon or metal ferrule

Electronics

Display

10 segment LED array, sequential lighting related to flow rate and flashing when trip point exceeded

Output Signals

Analog: 4-20 mA *

Relay: SPDT, 1A @ 24 Vdc, 120 Vac (ATEX: DC only)

Serial: RS232C I/O

* 500 ohm maximum load; user scalable; fault indication per NAMUR NE43 guidelines, user-selectable for high (>21.0 mA) or low (<3.6 mA) default

Instrument Set-up

Free FCI set-up and configuration software utility program and 3-wire-to-DB9 RS232 dongle are supplied for interface of the FS10i to user's PC. This interface is required to set the 4-20 mA output for the specific line size, flow range, and engineering units, as well as alarm trip point, hysteresis, and trip time delay.

Trip Point Hysteresis Control: 0-100% of span

Trip Point Time Delay: User settable for 0-65,000 seconds

Input Power: 24 Vdc (21.5 Vdc to 30 Vdc); 2.5 watts maximum

Operating Temperature: -40 °F to 160 °F [-40 °C to 71 °C]

Enclosure / Housing

Material: Stainless steel body; aluminum end-cap/top with polyester overlay and clear, silicone sheath impact guard

Protection Ratings

Non-Ex installations: IP65, IP66, IP67

FM, FMc approved: NEMA 4X

ATEX, IECEx approved: IP64

Agency Approvals

FM, FMc For use in Class I, II, III, Division 2, Groups A, B, C, E, F and G indoor/outdoor Type 4X Hazardous (Classified) Locations

ATEX/UKEX II 3 G Ex ec IIC T4 Gc,
II 3 D Ex tc IIIC T81°C Dc,
-40°C ≤ Ta ≤ +71°C
Input: 24Vdc, 2.5W
IP64

IECEX Ex ec IIC T4 Gc
Ex tc IIIC T81°C Dc
-40°C ≤ Ta ≤ +71°C
Input: 24Vdc, 2.5W
IP64

Ingress Protection: IP65, IP66, IP67 in non-hazardous locations

Other Compliances: CE Marking, CRN, complies with NEC & CEC code requirements of ANSI/ISA 12.27.01-2011 as a single seal device, UKCA, EAC / TR CU, KC Certification (Korea), RoHS Compliant, SIL2 Compliant; Safe Failure Fraction (SFF) 90%

Warranty: 1 Year

Flow Range/Pressure Service/Temperature Compensation

In-line Type					
Block 1 Code	Block 3 Code	Description	Flow Range	Pressure Service	Temperature Compensation
L	B	1 inch, in-line, air	1 SCFM to 50 SCFM [1,6 NCMH to 80 NCMH]	10 psi(a) to 50 psi(a) [0,7 bar(a) to 3,5 bar(a)]	Extended, 30 °F to 180 °F [-1 °C to 82 °C]
L	H	1 inch, in-line, compressed air	1.5 SCFM to 150 SCFM [2,4 NCMH to 240 NCMH]	50 psi(a) to 165 psi(a) [3,5 bar(a) to 11,4 bar(a)]	Extended, 30 °F to 180 °F [-1 °C to 82 °C]
M	B	2 inch, in-line, air	2 SCFM to 200 SCFM [3,2 NCMH to 320 NCMH]	10 psi(a) to 50 psi(a) [0,7 bar(a) to 3,5 bar(a)]	Extended, 30 °F to 180 °F [-1 °C to 82 °C]
M	H	2 inch, in-line, compressed air	4 SCFM to 400 SCFM [6,4 NCMH to 640 NCMH]	50 psi(a) to 165 psi(a) [3,5 bar(a) to 11,4 bar(a)]	Extended, 30 °F to 180 °F [-1 °C to 82 °C]

Insertion Type					
Block 1 Code	Block 3 Code	Description	Flow Range	Pressure Service	Temperature Compensation
E, F, J, or K	A	Insertion, air	1.25 SFPS to 125 SFPS [0,4 NMPS to 38 NMPS]	10 psi(a) to 50 psi(a) [0,7 bar(a) to 3,5 bar(a)]	Standard, 40 °F to 100 °F [4 °C to 38 °C]
	5	Insertion, air	1.25 SFPS to 125 SFPS [0,4 NMPS to 38 NMPS]	10 psi(a) to 50 psi(a) [0,7 bar(a) to 3,5 bar(a)]	Extended, 30 °F to 180 °F [-1 °C to 82 °C]
	7	Insertion, compressed air	4 SFPS to 400 SFPS [1,2 NMPS to 122 NMPS]	50 psi(a) to 165 psi(a) [3,5 bar(a) to 11,4 bar(a)]	Standard, 40 °F to 120 °F [4 °C to 49 °C]
	6	Insertion, compressed air	4 SFPS to 400 SFPS [1,2 NMPS to 122 NMPS]	50 psi(a) to 165 psi(a) [3,5 bar(a) to 11,4 bar(a)]	Extended, 30 °F to 180 °F [-1 °C to 82 °C]

Dimensional Drawings

In-line Type

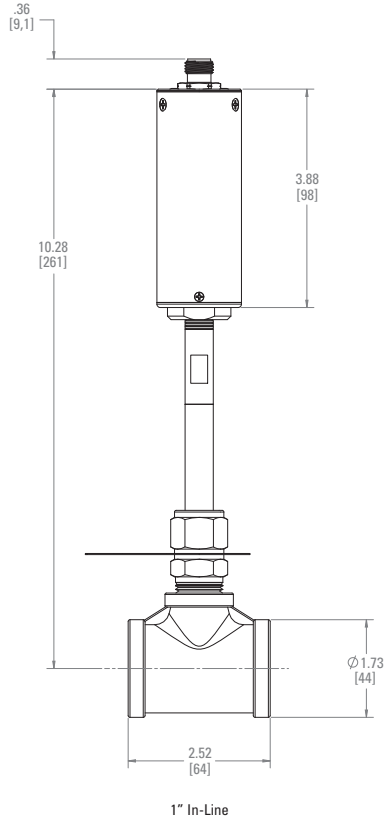

Insertion Type

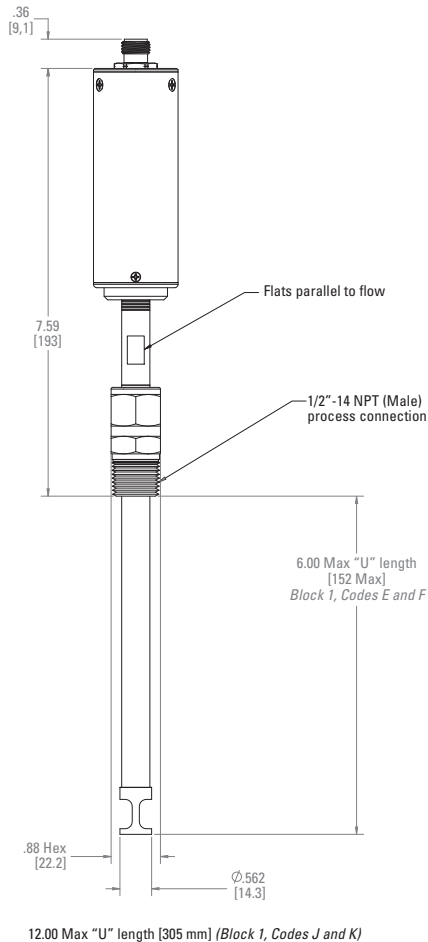

Input/Output Wiring Diagram

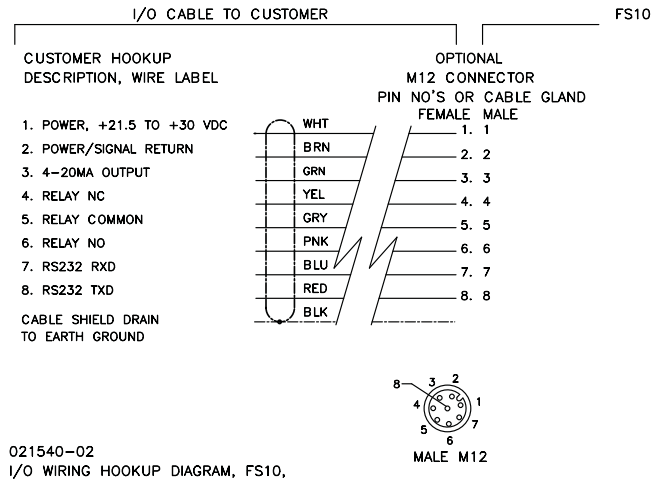

Front Panel / Top	Selections	Block 2 Order Code (FS10i OIS)
	With watertight cable gland to cable pigtail; 15' [5 m] <i>Not available with ATEX approval</i>	Block 2, Code 1
	With M12 (male) connector <i>For user supplied M12 cable</i>	Block 2, Code 2

FS10i-to-PC Interface

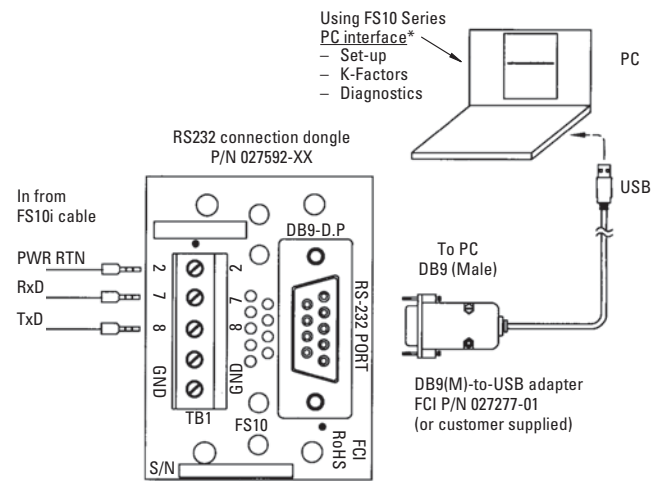

* FS10 Series PC interface included with product and downloadable from FCI's website:
<https://www.fluidcomponents.com/support/downloads-updates>
PC software allows set-up and configuration of an FS10 Series through the PC's RS232C or USB port.

Ordering Information FS10i -

Block No.

1 2 3 4

Code	[BLOCK 1] Process Connection and "U" Length
In-Line	
L	1" FNPT, 150 lb pipe tee ^{5,7}
M	2" FNPT, 150 lb pipe tee ^{5,7}
Insertion, "U" Length	
E	1/2" NPT compression fitting with Teflon ferrule; 6" [152 mm] length
F	1/2" NPT compression fitting with metal ferrule; 6" [152 mm] length
J	1/2" NPT compression fitting with Teflon ferrule; 12" [305 mm] length
K	1/2" NPT compression fitting with metal ferrule; 12" [305 mm] length
Code	[BLOCK 2] Power and Signal Output Connection Type
2	M12 connector only <i>No cable supplied</i> ¹
1	Fixed, watertight cable gland to wire pigtail; 15' [5 m] ⁴
Code	[BLOCK 3] Gas Medium and Calibration
In-Line ⁵	
B	Air ⁵
H	Compressed air ⁵
Insertion ⁶	
A	Air calibration ⁶
5	Air calibration; with extended temperature compensation ⁶
7	Compressed air calibration ⁶
6	Compressed air calibration; with extended temperature compensation ⁶
Code	[BLOCK 4] Agency Approvals <i>CE Marking always included</i>
0	None; CE Marking only
1	FM, FMc ²
3	ATEX, IECEx ²
5	EAC/TR CU ²
*	Other <i>Contact FCI for other approvals and conditions of use</i>

Accessories

Part Number	Description
M12 Connecting Cables ¹ M12(f)-to-pigtails with wire markers. 8-wire with shield. Polyurethane jacket. (For use with order Block 2 = Code 2.)	
022474-A02	2 m [6'] length
022474-A05	5 m [15'] length
022474-A10	10 m [30'] length
RS-232 Connection Dongles* (3-wire termination. DB9(f) breakout.) Includes GND points for power supply and mA output (except M12 field tap).	
* A dongle kit including both DIN rail and panel mounting items is supplied with every FS10i flow meter	
Replacement Dongles	
027592-01	DIN rail mounting*
027592-02	Panel mounting; adhesive-backed standoffs*
Optional Dongles	
027592-03	Wall plate mounting (fits 1 gang USA wall box)
027604-01	M12 field tap (for temporary use only. Requires the M12 connection on the FS10i, order Block 2, Code = 2)
Premium Connection Interface Modules – Full 8-wire termination and DB9(f) breakout	
027596-01	DIN rail mounting, non-isolated mA output
027596-02	DIN rail mounting, with isolated mA output
027596-03	Panel mounting, with non-isolated mA output
027596-04	Panel mounting, with isolated mA output
RS-232-to-USB (Type A) Adapter (includes driver software)	
027277-01	DB9 (m) with thumb-screws (for use with FS10i flow meter. Works with all dongles and connection interface modules).

Notes

- Connecting cable to be customer supplied, or select from Accessories list and order as separate item.
- Approvals for hazardous area are Division 2 / Zone 2 + Zone 22; see specifications for details.
- Cannot be selected with ATEX, IECEx, or EAC/TR CU approval (i.e. if Block 2 is Code 1, then Block 4 cannot be Code 3 or 5).

5. **In-line Type**

Block 1 Code	Block 3 Code	Description	Flow Range	Pressure Service	Temperature Compensation
L	B	1 inch, in-line, air	1 SCFM to 50 SCFM [1,6 NCMH to 80 NCMH]	10 psi(a) to 50 psi(a) [0,7 bar(a) to 3,5 bar(a)]	Extended, 30°F to 180°F [-1°C to 82°C]
L	H	1 inch, in-line, compressed air	1.5 SCFM to 150 SCFM [2,4 NCMH to 240 NCMH]	50 psi(a) to 165 psi(a) [3,5 bar(a) to 11,4 bar(a)]	Extended, 30°F to 180°F [-1°C to 82°C]
M	B	2 inch, in-line, air	2 SCFM to 200 SCFM [3,2 NCMH to 320 NCMH]	10 psi(a) to 50 psi(a) [0,7 bar(a) to 3,5 bar(a)]	Extended, 30°F to 180°F [-1°C to 82°C]
M	H	2 inch, in-line, compressed air	4 SCFM to 400 SCFM [6,4 NCMH to 640 NCMH]	50 psi(a) to 165 psi(a) [3,5 bar(a) to 11,4 bar(a)]	Extended, 30°F to 180°F [-1°C to 82°C]

6. **Insertion Type**

Block 1 Code	Block 3 Code	Description	Flow Range	Pressure Service	Temperature Compensation
E, F, J, or K	A	Insertion, air	1.25 SFPS to 125 SFPS [0,4 NMPS to 38 NMPS]	10 psi(a) to 50 psi(a) [0,7 bar(a) to 3,5 bar(a)]	Standard, 40°F to 100°F [4°C to 38°C]
	5	Insertion, air	1.25 SFPS to 125 SFPS [0,4 NMPS to 38 NMPS]	10 psi(a) to 50 psi(a) [0,7 bar(a) to 3,5 bar(a)]	Extended, 30°F to 180°F [-1°C to 82°C]
	7	Insertion, compressed air	4 SFPS to 400 SFPS [1,2 NMPS to 122 NMPS]	50 psi(a) to 165 psi(a) [3,5 bar(a) to 11,4 bar(a)]	Standard, 40°F to 120°F [4°C to 49°C]
	6	Insertion, compressed air	4 SFPS to 400 SFPS [1,2 NMPS to 122 NMPS]	50 psi(a) to 165 psi(a) [3,5 bar(a) to 11,4 bar(a)]	Extended, 30°F to 180°F [-1°C to 82°C]

- Certified Material Test Report (CMTR) are not available pipe tee selections (Block 1, codes L or M) See FCI Model ST75V if CMTR required.



www.FluidComponents.com

FCI's Quality Management System is ISO 9001 and AS9100 Certified

FCI World Headquarters 1755 La Costa Meadows Drive | San Marcos, California 92078 USA **Phone:** 760-744-6950 **Toll Free (US):** 800-854-1993

FCI Europe Persephonestraat 3-01 | 5047 TT Tilburg, The Netherlands | **Phone:** 31-13-5159989

FCI Measurement and Control Technology (Beijing) Co., LTD

Room 107, Xianfeng Building II, No.7 Kaituo Road, Shangdi IT Industry Base, Haidian District | Beijing 100085, P. R. China | **Phone:** 86-10-82782381



Copyright 2021-2024 by Fluid Components International LLC. All rights reserved. Manufactured in accordance with one or more of the following patents: US Patent Numbers 7,201,033; 8,806,955; 9,010,994 (CN, DE, GB, KR, NL); 9228881; 9528868; 9671265; 11,105,666 (CA, CN, DE, GB, KR); China Patent Number 2017800582146; and other US and foreign applications pending FCI and FCI design, FLT, Vortab, FCI Nuclear and FCI Nuclear design are registered trademarks of Fluid Components International LLC. Information subject to change without notice.

HART® is a registered trademark; Foundation™ Fieldbus is a trademark of FieldComm Group; PROFIBUS® is a registered trademark of PROFIBUS.

1223

Doc No. 02MK011557 D Page 4 of 4